

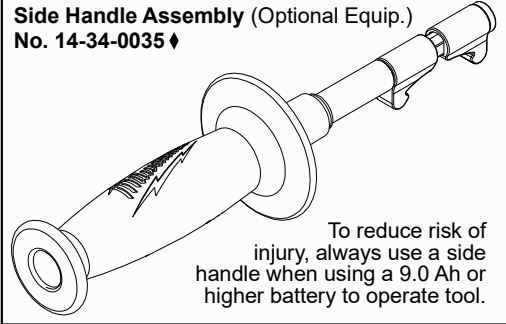

# SERVICE PARTS LIST

**BULLETIN NO.**  
**54-06-2511**

SPECIFY CATALOG NO. AND SERIAL NO. WHEN ORDERING PARTS		REVISED BULLETIN 54-06-2510	DATE Sept. 2017
<b>M18™ 1/2" DRIVER-DRILL</b>			
CATALOG NO.	<b>2606-20</b>	STARTING SERIAL NO.	<b>F24B or F24C</b>
		<b>WIRING INSTRUCTION SEE PAGE 3</b>	



**EXAMPLE:**  
Component Parts (Small #) Are Included  
When Ordering The Assembly (Large #).

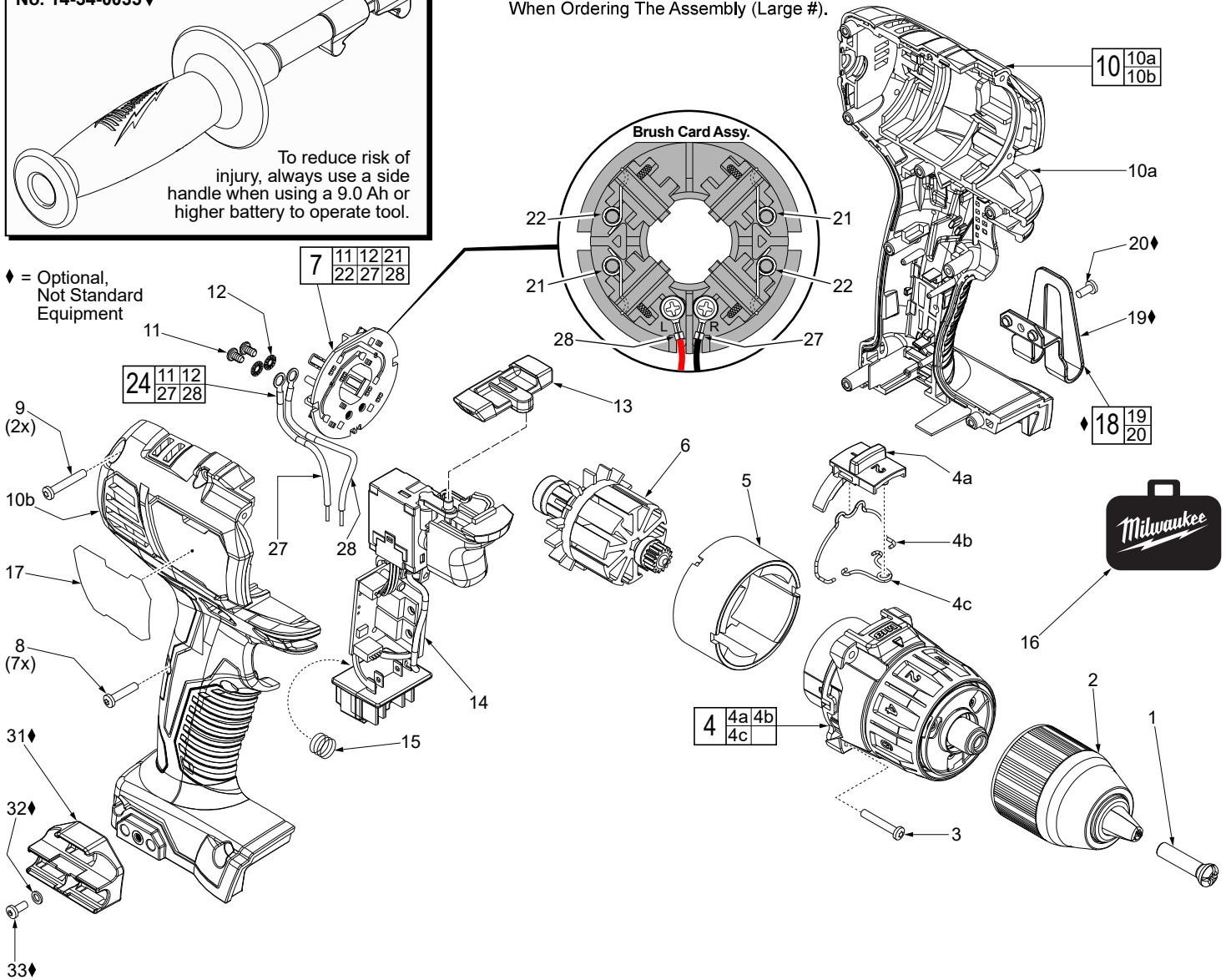
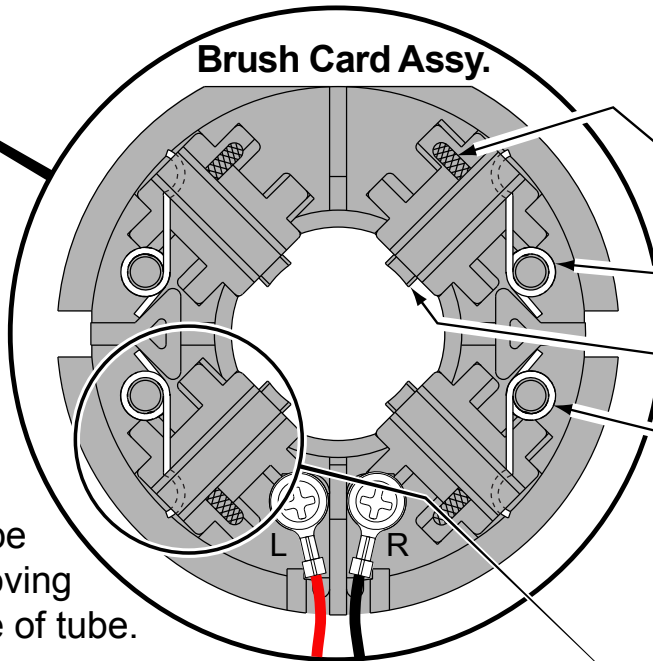
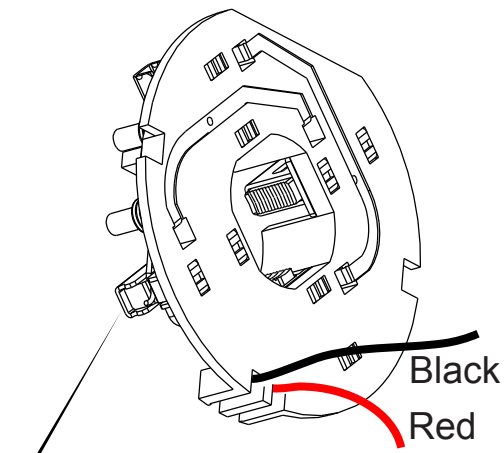

FIG.	PART NO.	DESCRIPTION OF PART	NO. REQ.
1	05-88-1500	M6 x 27mm LH Chuck Screw	1
2	42-66-2606	Keyless 1/2" Chuck	1
3	06-82-0135	M3 x 18mm Pan Hd. Plastite T-10 Screw	4
4	14-29-2606	Gear Box Assembly	1
4a	45-24-2607	Speed Selector Slide	1
4b	44-10-2607	Speed Change Lever	1
4c	40-50-2607	Torsion Spring	1
5	18-01-3020	Service Field	1
6	16-07-2610	Service Armature	1
7	22-22-2607	Brush Card Assembly	1
8	06-82-6350	M3 x 16mm Pan Hd. Plastite T-10 Screw	7
9	05-88-0675	M3 x 20mm Pan Hd. Plastite T-10 Screw	2
10	31-44-2608	Handle Assembly	1
10a	-----	Left Handle Halve	1
10b	-----	Right Handle Halve	1
11	05-88-0928	M3 x 5mm Pan Hd. T-10 Screw	2
12	45-88-1980	Spring Washer	2
13	42-42-2607	Forward/Reverse Shuttle	1
14	14-20-2608	Electronics Assembly (Consists of Switch, PCBA, LED and Battery Terminal Block)	1

FIG.	PART NO.	DESCRIPTION OF PART	NO. REQ.
15	40-50-1090	Terminal Block Spring	1
16	42-55-2606	Blow Molded Carrying Case	1
17	12-20-2607	Service Nameplate	1
18	42-70-2653	Belt Clip Assembly, <i>Optional</i>	1
19	-----	Belt Clip, <i>Optional</i>	1
20	-----	Belt Clip Screw, <i>Optional</i>	1
21	-----	Brush Spring - Right Hand	2
22	-----	Brush Spring - Left Hand	2
24	14-46-2394	Leadwire/Screw/Washer Kit	1
27	-----	Leadwire Assembly - Black - Right Side	1
28	-----	Leadwire Assembly - Red - Left Side	1
31	43-72-0550	Bit Holder, <i>Optional</i>	1
32	45-88-1935	Washer, <i>Optional</i>	1
33	06-82-5275	6-32 x 5/16" Pan Hd. T-15 Screw, <i>Optional</i>	1

# INSTALLING BRUSH SPRINGS ON A BRUSH CARD ASSEMBLY WITH FOUR (4) BRUSHES

There are two Right Hand Brush Springs and two Left Hand Brush Springs. Follow the instructions below for proper installation.



- Brush Shunt (4 places)
- Right Brush Spring (2x)
- Carbon Brush (4x)
- Left Brush Spring (2x)

Be sure carbon brush is in brush tube with brush shunt moving freely in side groove of tube.

Place brush spring over post with short leg positioned downward as shown. Be sure spring is completely down with short leg trapped against 'Y' shaped wall on brush card.

While holding spring in place, bring the long leg of spring over the brush tube and through rear opening of tube. Position rounded hook of spring in groove on back of carbon brush. Be sure to check for free movement between carbon brush, brush shunt and brush spring.

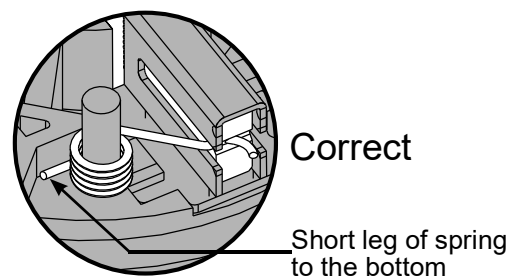
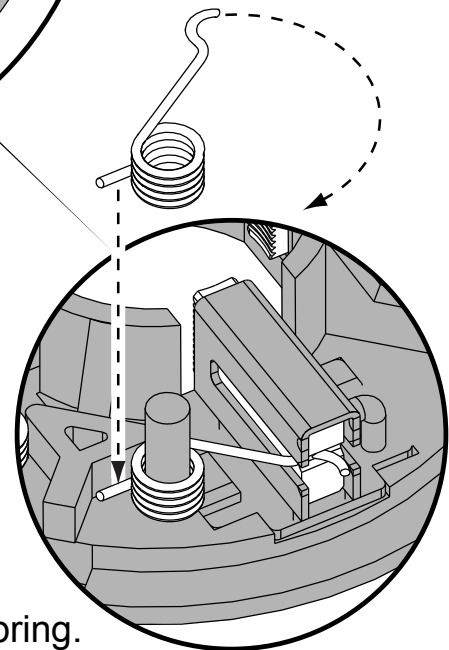

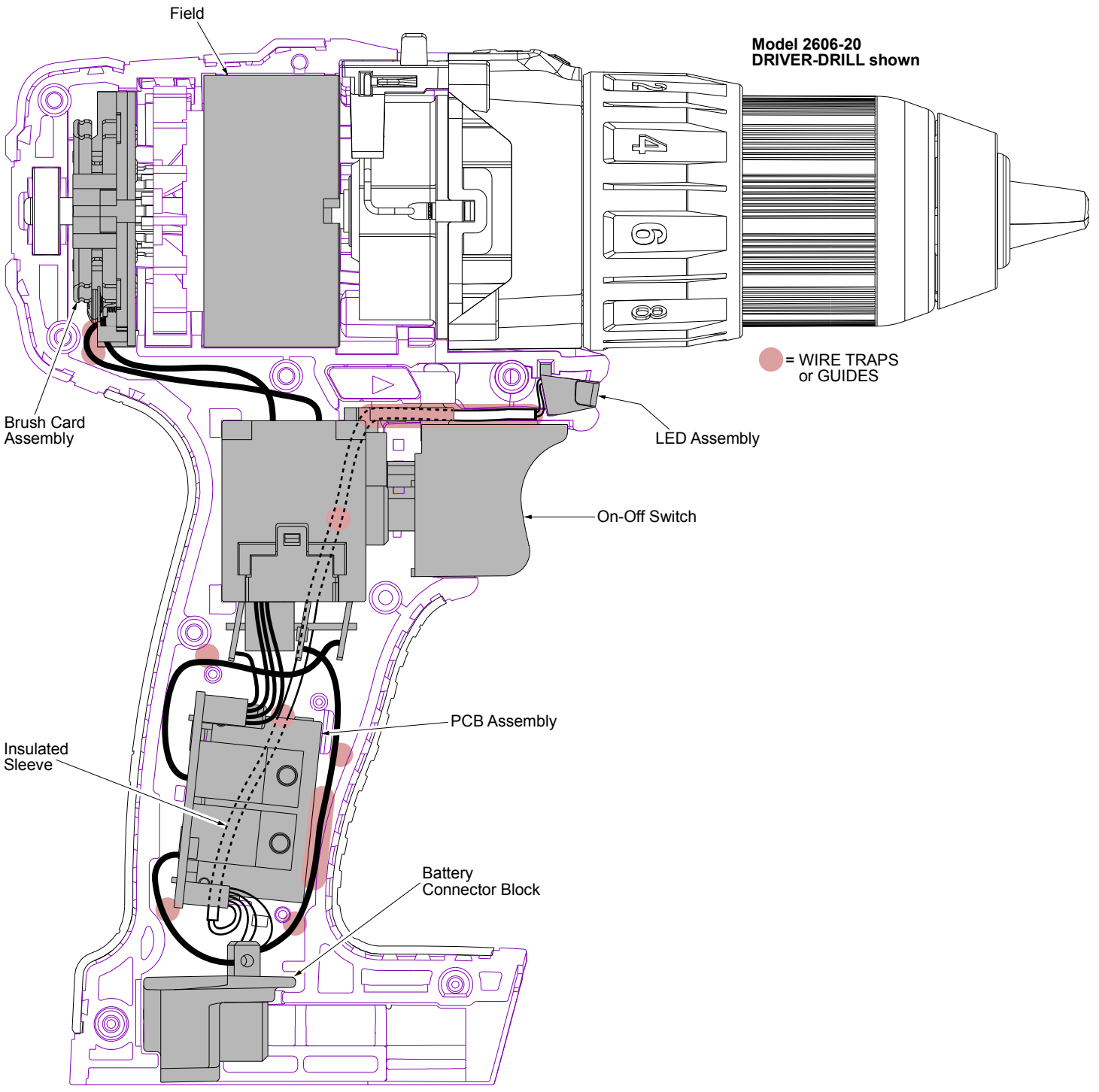

**Model 2606-20  
DRIVER-DRILL shown**