

## OWNER'S GUIDE

# PORTABLE BASEBOARD



Thank you for your purchase! Question or problem? Let us solve it with a single phone call, email or online chat! We'll save you a trip back to the store!

### Cadet Customer Service

Phone: **855.223.3887** (from US)  
**800.668.6663** (from Canada)  
email: [customerservice@cadetheat.com](mailto:customerservice@cadetheat.com)  
Live chat: [cadetheat.com](http://cadetheat.com) (contact us)

For how-to videos or more information, please visit:  
<http://cadetheat.com/support/install-help>

**CADET**   
INVITING WARMTH  
[cadetheat.com](http://cadetheat.com)  
855.CADET.US  
Vancouver, Washington



# IMPORTANT INSTRUCTIONS

⚠ When using electrical appliances, basic precautions should always be followed to reduce the risk of fire, electric shock, and injury to persons, including the following:

1. Read all instructions before installing or using this heater.
2. Use this heater only as described in this manual. Any other use not recommended by the manufacturer may cause fire, electric shock, or injury to persons.
3. Always plug heaters directly into a wall outlet/receptacle. Never use with an extension cord or relocatable power tap (outlet/power strip).
4. Connect to properly grounded outlets only.
5. Do not operate any heater with a damaged cord or plug or after the heater malfunctions, has been dropped or damaged in any manner. Discard heater or return to an authorized service facility for examination, and/or repair.
6. Do not run cord under carpeting. Do not cover cord with throw rugs, runners, or similar coverings. Do not route cord under furniture or appliances. Arrange cord away from traffic area and where it will not be tripped over.
7. Always unplug heater when not in use.
8. To disconnect heater, turn the thermostat knob left, to the smallest dot, then remove plug from outlet.
9. A heater has hot and arcing or sparking parts inside. Do not use it in areas where gasoline, paint, or flammable liquids are used or stored.
10. This heater is hot when in use. To avoid burns, do not let bare skin touch hot surfaces. Keep combustible materials, such as furniture, pillows, bedding, papers, clothes, and curtains away from heater.
11. To prevent a possible fire, do not block air intakes or exhaust in any manner. Do not use on soft surfaces, like a bed, where openings may become blocked.
12. Do not insert or allow foreign objects to enter any ventilation or exhaust openings as this may cause an electric shock or fire, or damage the heater.
13. This heater is not intended for use in bathrooms, laundry areas and similar indoor locations. Never locate heater where it may fall into a bathtub or other water container.
14. Extreme caution is necessary when any heater is used by or near children or invalids and whenever the heater is left operating and unattended.
15. Do not use outdoors.

# SAVE THESE INSTRUCTIONS

Unanswered questions? Call our technical support team in Vancouver, Washington at **855.CADET.US (855.223.3887)** or **360.693.2505**.

# INSTALLATION INSTRUCTIONS

1. **CAUTION – High Temperature.** Keep electrical cords, drapes, and other furnishings away from heater.
2. To reduce the risk of fire, do not store or use gasoline or other flammable vapors and liquids in the vicinity of the heater.
3. Maintain 12 inches (30.5 cm) minimum clearance from all objects above and in front of heater.

## ASSEMBLY

Remove the heater and all items from the carton. Your heater is completely assembled and has been designed to tilt slightly backward when its feet are flat on the floor.

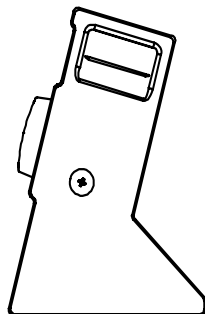
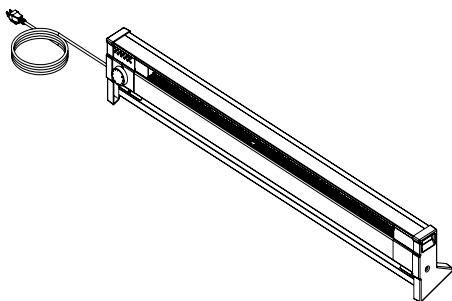

side view

## GROUNDING

Your portable heater is 120 volts, and it comes with a cord that has a grounded, 3-prong plug. See Figure 1.

If you only have a 2-prong receptacle in your home, for safety reasons you must use a grounding plug adapter. The green grounding lug extending from the adapter must be connected to a permanent ground, such as a properly grounded outlet box. See Figure 2.

The adapter isn't necessary if you have a 3-slot grounded receptacle.

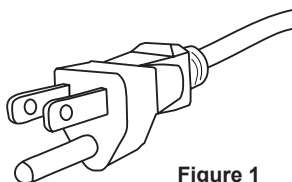

Figure 1

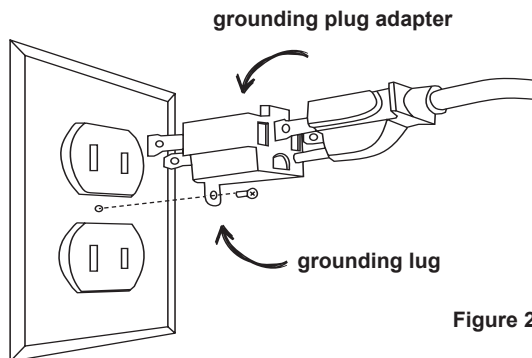

Figure 2

# OPERATING INSTRUCTIONS

1. Do not tamper with the high-temperature safety shutoff.
2. Do not operate without the feet attached.

After placing your heater on the floor, plug it in, turn it to the highest setting and allow it to run for **at least 30 minutes**. If your room doesn't get warmer, please contact us.

**PLEASE NOTE:** On initial start-up, some smoking may occur as the element initially burns off residue from manufacturing. It typically goes away within several hours. If it persists, turn your heater off, unplug it and contact customer service **toll free**:

855.223.3887 (from US) or 800.668.6663 (from Canada)

**live chat:** [cadetheat.com/customer-service](https://cadetheat.com/customer-service)

## How to operate your heater

The room temperature is controlled by the thermostat on the heater. Simply plug it in and follow the steps below to adjust the temperature to your comfort level.

1. Turn the thermostat knob all the way to the right.
2. When the room reaches your comfort level, turn the knob to the left, just until it clicks. The heater will automatically keep the room temperature around this setting.
3. To reduce the room temperature, turn the knob to the left. To increase the room temperature, turn the knob to the right.

The larger dots indicate a higher temperature setting. The smallest dot is an OFF position.

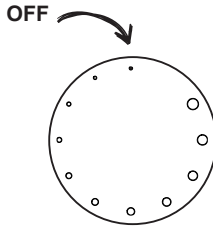

## High-temperature and safety tip-over shutoffs

Your portable electric baseboard comes with a built-in high-temperature safety shutoff that stops electricity flowing to the heater if it gets too hot inside. This automatically resets after cooling.

Your heater also includes a safety tip-over switch that disconnects power if it falls over, and resets as soon as the heater is standing up again.

# MAINTAINING YOUR HEATER

Clean heater at least every 6 months or as required.

1. It is important that you verify the heater is unplugged and the element is cool.
2. Wipe cover with damp cloth and dry.
3. Use the hose on your vacuum to clean the heater. Do not touch the element.
4. Plug in the heater when complete.

Any service other than cleaning should be performed by an authorized service representative.

## TROUBLESHOOTING

Symptom	Problem	Solution
Heater is making noise.	1. Heater makes creaking or popping noises.	1. The heating element expands slightly when turned on. This is normal.
Heater smells when first plugged in or after not being used.	1. Odor from element manufacturing process. 2. Dust or lint inside the heater.	1. On initial start-up, the heater may cause an odor due to the manufacturing process. It typically goes away within several hours. 2. Clean heater (see "MAINTAINING YOUR HEATER" above for instructions).
Heats briefly then stops.	1. High-temperature safety shutoff has tripped. 2. Safety tip-over switch has tripped.	1. Remove all obstructions. Do not block heater. Maintain 12 inches (30.5 cm) above and front. Keep heater free of lint and dust. The high-temperature safety shutoff resets after cooling. 2. Stand the heater up so it's in an upright position. The tip-over switch resets immediately.
Heater doesn't turn off.	1. Incorrect heater wattage for room size. 2. Thermostat is defective.	1. If additional heat is needed consult an electrician as circuit(s) may be limited. 2. Replace thermostat.

## WARRANTY

For more effective and safer operation and to prolong the life of the heater, read the Owner's Guide and follow the instructions. Failure to properly maintain the heater will void any warranty and may cause the heater to function improperly.

**LIMITED TWO YEAR WARRANTY:** Cadet will repair or replace any Cadet Portable (P) heater found to be defective within two years after the date of purchase.

### These warranties do not apply:

1. Damage occurs to the product through improper installation or incorrect supply voltage;
2. Damage occurs to the product through improper maintenance, misuse, abuse, accident, or alteration;
3. The use of unauthorized accessories or unauthorized components constitutes an alteration and voids all warranties. Refer to Cadet website or call customer service at 855.223.3887 or 360.693.2505 for list of authorized accessories and components.

4. Cadet's warranty is limited to repair or replacement.
5. In the event Cadet elects to replace any part of your Cadet product, the replacement parts are subject to the same warranties as the product. The installation of replacement parts does not modify or extend the underlying warranties. Replacement or repair of any Cadet product or part does not create any new warranties.

If you believe your Cadet product is defective, please contact Cadet during the warranty period, for instructions on how to have the repair or replacement processed.

### Parts and Service

Visit [cadetheat.com/parts-service](http://cadetheat.com/parts-service) for information on where to obtain parts and service.

To register your product, visit [cadetheat.com/product-registration](http://cadetheat.com/product-registration)



### Reduce-Reuse-Recycle

This product is made primarily of recyclable materials. You can reduce your carbon footprint by recycling this product at the end of its useful life. Contact your local recycling support center for further recycling instructions.

More frequently asked questions on our website here: [cadetheat.com/support/FAQ](http://cadetheat.com/support/FAQ)