

# SHELTER FURNACE

## WOOD BURNING OUTDOOR FURNACE

MODEL: SF4200



Manufactured by:  
Shelter Furnace  
10950 Linpage Place  
Saint Louis, MO 63132  
1-800-875-4788

**MADE IN USA**



**Intertek**

Tested to  
UL391 and  
CSA B366.1-2011  
and B415.1-2010  
Standards



## **PROPER BURN PRACTICES** **FOR MAXIMUM EFFICIENCY AND SAFETY!**

- The chimney is one of the most important elements of the furnace. If the chimney is not connected properly and installed according to manufacturer's specification and national and local codes, the unit is not safe and will not burn efficiently. Lack of proper chimney installation will cause unit to produce more smoke and less heat output. See Pages 6-7 of this manual to ensure proper installation.
- Proper use of all electrical components is essential: For instance, the wall thermostat must be hooked up to the furnace and the draft blower must be in operation at all times. This will increase furnace efficiency and produce more heat output.
- Wood that is properly cut and stored to dry will produce more BTUs and higher heat output than wood that has a higher moisture content. Wood with higher moisture content will create creosote in the chimney and cause flue fires.
- There should be no alteration of the Shelter Furnace in any way, as this will void the UL391 listing and affect the operation of the furnace. This will also void the warranty of the unit.
- Shelter Furnace makes two types of units, indoor as well as outdoor furnaces. The indoor units are manufactured and tested for indoor applications only. They are not meant to go outside the house but must be placed indoors in a basement or utility room. Any indoor unit placed outside the home in a shed or building, will void warranty, violate the safety listing, and will not produce the maximum efficiency possible with this unit. For outdoor applications please use the SF4200.



# **SHELTER OUTDOOR FURNACE MANUAL**

MODEL: SF4200

EPA Certified to the Warm Air Furnace NSPS requirements, for sale May 2017 through May 2020.

## **SAVE THESE INSTRUCTIONS**

Congratulations! You have selected the finest quality outdoor wood burning furnace, manufactured with pride in the USA. Please take a few moments to carefully read the owner's manual. By taking the time to familiarize yourself with your new Shelter Furnace, you will be able to look forward to years of trouble-free, dependable service.

### **Installation:**

- First, check local codes. The installation must comply with all local rulings and requirements.
- This furnace is an outdoor hot air furnace and must not be altered in any way.
- This furnace requires a back-up electric generator, 2000 watts minimum, in case of power failure.
- Always have a properly installed and functioning smoke detector installed in your home.
- To prevent accidental injury, do not allow anyone who is unfamiliar with the furnace to operate it.
- **Spend time familiarizing yourself with your Shelter Furnace, especially the different settings and the effects they have on burn patterns.** It is impossible to predict how each setting will affect your furnace, due to variations in conditions, fuels, and temperatures.
- When making plans to install your outdoor furnace, the first thing you need to think about is the placement of the unit. Although you can install the Shelter Furnace up to 30 feet from the home, a much shorter distance is recommended to provide better airflow. The furnace has been tested for clearance of 12 inches from the home; this would give maximum airflow and provide the highest efficiency.

### **Transportation Damage**

Every effort has been made to ensure that your Shelter Furnace will arrive in perfect condition. Any visible damage should be noted on the freight bill at the time of delivery. If upon unpacking your furnace, you find damage has occurred during transit, notify your dealer immediately. Your dealer will advise you what actions must be taken to correct the problem.

### **Disclaimer Notice**

The listed BTU rating of your new Shelter Furnace was obtained using laboratory calculations. **The actual BTU output you experience may vary somewhat depending on the type, condition, and moisture content of the fuel used, damper adjustment, chimney type and other variables.** Therefore, the manufacturer disclaims any guarantee as to the BTU output or capacity of your furnace. Shelter Furnace disclaims any responsibility for the following: installation of a furnace that has been altered or modified in any way; installation of the furnace other than as instructed in this manual; installation and or use of any component or part not approved by Shelter Furnace for use on this furnace. Be sure to complete and return your warranty card within 30 days of purchase in order to activate warranty coverage on your furnace.

### **Manufacturer's Notice**

Please be advised that periodic changes are made to improve the furnaces. Therefore the information in this manual may not be completely applicable to your Shelter Furnace. Please refer to markings on the appliance for additional information.

**THIS IS AN OUTDOOR WOOD BURNING FURNACE ONLY AND SHOULD NOT BE ALTERED IN ANY WAY.**

# **TABLE OF CONTENTS**

<b>General Information</b>	3
<b>Furnace Clearances and Operation</b>	4
Installing the Anchor Plate	5
Chimney Location and Clearances	6
Wood Storage and Care	7
<b>Furnace Installation</b>	7
Grounding Furnace	8
Hot Air Duct and Cold Air Return Installation	8
Burying Ductwork	9
Types of Installations	10
Central Duct Connections	10
Mobile Home Down Draft Furnace Connection	11
No Ductwork Connection	11
<b>General Operation</b>	12
<u>FIRST FIRE</u>	12
<u>LOADING WOOD</u>	12
Fuel Recommendations	13
Disposal of Ashes	13
Heat Dump and Fuse Link System	14
Draft Blower	14
<u>CREOSOTE FORMATION</u>	14
<u>CREOSOTE PREVENTION</u>	15
Power Failure	15
<b>Maintaining Your Furnace</b>	15
<b>Grate System Diagram</b>	18
<b>Blower Motor Assembly Diagram</b>	18
<b>Wiring Diagram</b>	19
<b>Troubleshooting</b>	20
<b>Warranty Information</b>	25

**DOUBLE CHECK TO MAKE SURE YOU HAVE RECEIVED ALL OF THE REQUIRED COMPONENTS. IF YOU FIND THAT THERE IS A PART MISSING, CALL 1-800-875-4788 FOR FASTEST SERVICE. PLEASE DO NOT GO BACK TO THE STORE. THE STORE MAY NOT HAVE REPLACEMENT PARTS.**

## General Information

---

**ALWAYS KEEP YOUR WOOD COVERED YEAR ROUND; DRY WOOD WILL PRODUCE MORE BTU OUTPUT AND LONGER BURN TIMES.**

This EPA-Approved Shelter Furnace is an airtight central outdoor furnace engineered to accommodate the heating requirements of the average sized home, even during winter's coldest months, with a heat output range up to 140,000 BTUs. It is constructed of high grade, heavy gauge steel and is continuously welded to assure the utmost in structural strength. In addition, the heat exchanger is lined with insulated stainless steel to ensure many years of energy efficient service.

The design of the secondary combustion chamber increases fuel efficiency by creating a "secondary burn" of smoke and wood gases before they are vented up the chimney. By sending the gases back through the secondary combustion chamber, less fuel is wasted, the furnace burns at a higher efficiency, and for longer burn times.

The cast iron door is custom fitted to provide an airtight seal, greatly extending the burn time and ensuring maximum efficiency in fuel consumption. The heavy-duty cast iron grates aid in convenient ash removal and reduce maintenance; the insulated wrap-around sides are designed for maximum heat transfer.

For total comfort and convenience, a thermostatically controlled 1800 CFM circulation blower system has been installed. The blower draws the cold air from the home, across the heat chamber before going through the hot air duct and returning the warm air to your home.

This fully automatic blower disperses heat rapidly to your home, minimizing recovery time. Average burn time per load of fuel is 8 to 12 hours depending on wood type and condition, desired temperature within the home and amount of fuel. We have incorporated all of these features as standard equipment, offering you the most efficient, durable and affordable appliance possible. Abnormally cold weather could reduce the burn time.

Your Shelter Furnace is designed to be either a supplemental or central heating source for your home. This wood burning furnace may be installed in parallel with a properly operating electric, gas or oil-fired central furnace, listed or certified in accordance with a nationally recognized safety standard, and within clearances specified on Shelter Furnace nameplate. When in a parallel installation the static pressure of the central furnace plenum may not exceed 0.15 water column inches and the maximum setting on central furnace limit switch is 182°F. With the Shelter Furnace in an "Interconnection Arrangement" your furnace should be upstream of the central furnace. The Shelter Furnace warm air supply should never be connected to return air for the central furnace. A qualified installer should perform the installation.

This is a wood burning furnace – it cannot be turned "off and on" to control the furnace temperature like gas or electric furnaces. Once the fire is established, it has to burn until it burns itself out.

This wood heater needs periodic inspection and repair for proper operation. It is against federal regulations to operate this wood heater in a manner inconsistent with operating instructions in this manual. Efficiency was determined using the higher heating value of the fuel per B415.1-10 testing requirements. Dry seasoned wood will develop greater BTU output. A well-insulated dwelling will always lead to better results and overall improved fuel usage efficiency.

### **INCLUDED WITH YOUR SHELTER FURNACE:**

- 1 – 10" starter collar for warm air exit
- 1 – 12" starter collar for cold air return
- 1 – owner's manual with warranty card
- 1 – wall thermostat (you must purchase 2-wire thermostat wire separately)
- 4 – #10 x 3/4" screws for chimney anchor plate
- 1 – anchor plate
- 1 – spare fuse link

## Furnace Clearances and Operation

---

Before beginning your installation, consult with local authorities regarding the codes governing all such installations. DO NOT connect your Shelter Furnace to any flue that is servicing ANY other appliances.

The Shelter Furnace may be placed outdoors or indoors. If outdoors, it must be placed on a level, non-combustible base, preferably a 4' x 8' concrete pad, as close to the home as clearances to combustibles permit – do not place the furnace more than 30 feet from the house. The furnace must be connected to a grounded electrical circuit with access to a backup generator (2000 watt minimum). If locating the furnace more than 10' from the home, a minimum of 6' of Class "A" HT 2100 All Fuel 6 inch Chimney Pipe is required. If installing indoors, your furnace must be placed on a non-combustible floor. Air for combustion must be provided into the room where the furnace is located. Allow air free access to furnace for combustion and ventilation.

Maintain the following clearances:

- Front = 48 inches
- Rear = 12 inches
- Sides = 6 inches
- Heat Duct = 6 inches for the first 16 inches from the back of the furnace, and 3 inches beyond

Class "A" HT 2100 All Fuel 6 inch Chimney Pipe is required for optimum performance and must maintain a 2 inch clearance from combustibles. The Shelter Furnace will ship with an anchor plate and four #10  $\frac{3}{4}$ " galvanized screws with washers and gaskets to match the chimney your dealer supplies. If the anchor plate provided with your furnace does not fit the chimney your dealer has in stock, please call our toll free number, 1-800-875-4788 for assistance.

**IMPORTANT:** Please keep in mind that different chimney manufacturers' pipe will not interchange with other brands. A tube of high-temp silicone caulk is included with your furnace. Before using the silicone to install the anchor plate to the top of your Shelter Furnace, ensure the chimney you purchased will fit the anchor plate.

Guy wire brackets are attached to the sides of the Shelter Furnace. A heavy gauge of stainless steel wire can be purchased from your dealer or at a local hardware store to use as guy wire to help support your chimney. Attach the appropriate chimney pipe lengths to the adaptor plate finishing with a chimney cap. **IMPORTANT:** Your furnace requires its own chimney system and cannot share a flue with any other product. **DO NOT USE GALVANIZED OR BLACK PIPE TO VENT YOUR FURNACE.**

Once you have met local requirements governing the installation and positioning of the furnace, install the Electrical Control Kit. Open the Electrical Control Kit and confirm that all items were shipped with your Shelter Furnace. **IMPORTANT: ENSURE THE POWER CORD IS PLUGGED INTO A GROUNDED ELECTRICAL SUPPLY.** Do NOT connect the furnace to your ductwork at this time. Build a small fire – DO NOT fill the firebox to full capacity during the initial firing. Your new furnace has a protective coating of oil or paint on the surface, which could produce smoke or odors during the initial firing and will burn off. Allow adequate ventilation during this initial, break-in firing to let any odors escape. This initial firing also allows the metals to cure. After successfully completing the initial firing, you are ready to attach the hot air duct and cold air return to complete your installation. See diagram below.

This wood heater has a manufacturer-set minimum low burn rate that must not be altered. It is against federal regulations to alter this setting or otherwise operate this wood heater in a manner inconsistent with operating instructions in this manual.

You must install the wall thermostat for the furnace to operate. When the wall thermostat calls for heat, the draft motor will engage, allowing combustion air to flow into the firebox. This causes a hotter fire, increasing the heat in the heat chamber. When the home reaches the selected temperature on the wall thermostat, it will disengage the draft motor and the fire in the firebox will reduce to a low burn until the thermostat calls for another heat cycle. The fan limit control is factory pre-set at 150° as the "ON" temperature setting and 100° as the "OFF" temperature setting. This means when the heat chamber reaches 150°, the blower will turn on; when the chamber cools, the blower will turn off. This process is called a heating cycle.

**IMPORTANT: FOR TECHNICAL SUPPORT OR CUSTOMER SERVICE ISSUES, DO NOT RETURN TO THE STORE, CALL 1-800-875-4788.**

THIS UNIT IS NOT TO BE CONNECTED TO A CHIMNEY FLUE THAT SERVES ANOTHER APPLIANCE.

### **INSTALLING THE ANCHOR PLATE:**

Note: Check with your dealer for the anchor plate that connects to Class A HT2100 chimney. IMPORTANT: BEFORE YOU FOLLOW THE NEXT STEPS, ENSURE THE ANCHOR PLATE YOU RECEIVE MATCHES YOUR CHIMNEY PIPE, AS CHIMNEY PIPE IS NOT GENERIC AND WILL NOT INTERCHANGE.

1. Using the diagram below as a guide, caulk the bottom of the anchor plate around the center pipe shaft.

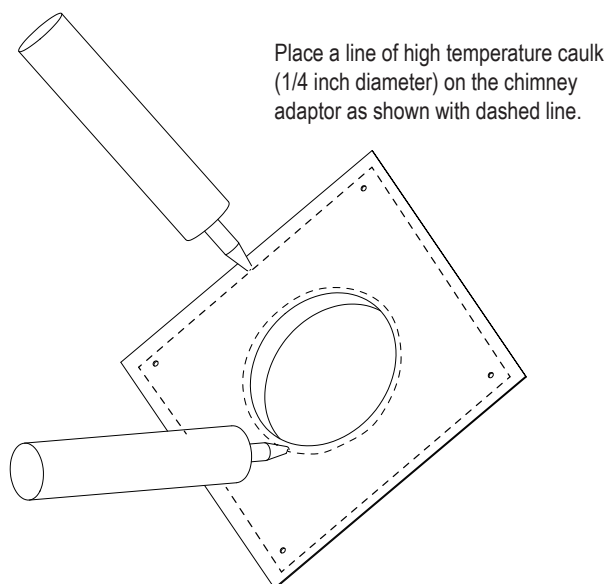

2. Install the anchor plate to the top of your furnace using four #10 3/4" galvanized screws with rubber gaskets.
3. Install the chimney pipe to your outdoor furnace.
4. After all the chimney components are installed including the cap, follow the diagram below to caulk around the chimney pipe as well as around the outer edge of the anchor plate.

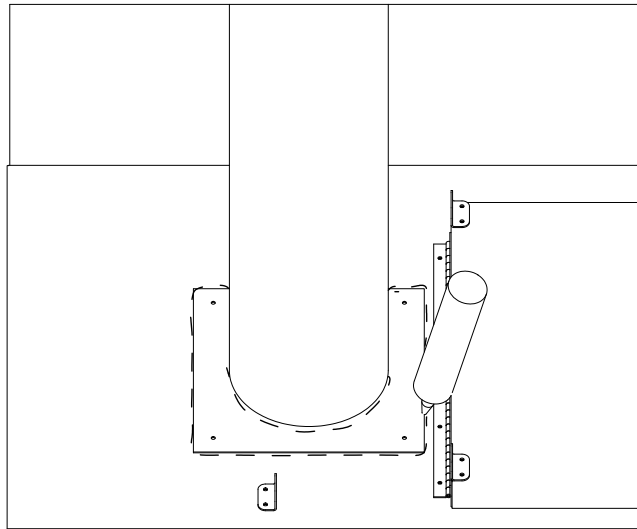

**Chimney Location and Clearances:**

Requires Class “A” HT 2100 All Fuel 6” Chimney

The furnace requires a minimum of 6 feet of chimney. When positioning the furnace, maintain the “10/2 Rule” for the chimney – In order to determine proper chimney height above the roof, measure from the side of the chimney horizontally. As you move up the chimney, the length of the measurement increases. Once this measurement reaches 10 feet, this height on the chimney is your base height. The chimney must be 2 feet taller than the base height. If the chimney is closer than 10 feet from the peak of the roof, the chimney must be 2 feet higher than the peak of the roof. The 2 feet above the base height does not include the cap. The furnace must be placed on a level, non-combustible surface or 4 foot x 8 foot concrete pad.

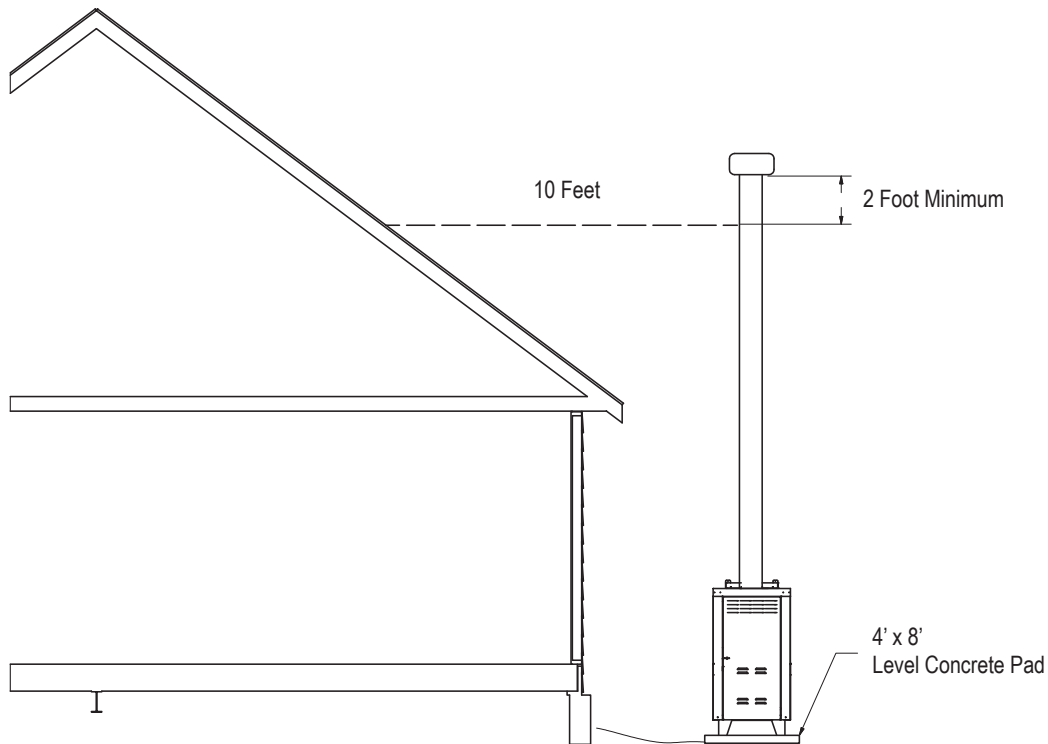

## **Wood Storage and Care:**

KEEP WOOD COVERED AT ALL TIMES. This cannot be over emphasized. Wood stored/stacked, uncovered, exposed to rain and snow has a higher moisture content, causing the formation of creosote, excess smoke, and it takes longer to ignite as well as producing poorer fires with lower sustained BTU output. Unseasoned wood ends up costing more in time trying to achieve and maintain proper temperatures in the firebox, while using more wood with less heat output. Covering the woodpile will keep it dry and offer you the hottest fires with the greatest BTU output. If you store the wood near your furnace, be sure to maintain proper clearance from the furnace to prevent a fire hazard. DRY WOOD WILL PRODUCE HOTTER FIRES AND INCREASE BTU OUTPUT.

Follow instructions included with the moisture meter that was supplied with this unit to make sure that you are using seasoned wood to achieve the cleanest burn and highest efficiency possible.

When using the moisture meter, in addition to following the manufacturer's instructions, look for readings under 30% moisture content. Also seasoned wood will be noticeably lighter weight than green wood, generally has darker ends with cracks or splits visible.

**IMPORTANT: FOR TECHNICAL SUPPORT OR CUSTOMER SERVICE ISSUES, DO NOT RETURN TO THE STORE, CALL 1-800-875-4788.**

## **Furnace Installation**

---

- Installation is to be performed by a qualified installer.
- Always consult local building inspectors for codes concerning the installation of your furnace.
- Always have access to a backup generator, 2000 watt minimum.
- Use Class "A" HT 2100 All Fuel 6 Inch Chimney for your Shelter Furnace.
- Never use galvanized pipe in your flue connection.
- Inspect the flue periodically for structural integrity.
- Clean the flue regularly to prevent creosote accumulation.
- Never use chemicals or gasoline to start or maintain your fire.
- Never burn garbage, oil, trash, or gasoline in your furnace.
- Never leave the fuel door or ash door open during operation.
- Remove ashes on a daily basis, before ashes reach the grates, to ensure proper air flow.
- Never use wet, unseasoned wood or wood exposed to a recent rainfall. Doing so causes a rapid accumulation of hazardous creosote, which is a proven cause of flue fires.
- Never burn plastics, wood products containing glue, or wood that has been treated with chemical preservatives in your Shelter Furnace. The combustion of these substances may release harmful, toxic gases.
- NEVER UNPLUG THE FURNACE FROM THE POWER SOURCE. THIS WILL CAUSE THE FURNACE TO OVERHEAT. If it is too warm in the house, lower the temperature on the thermostat; and/or use less fuel.
- Never leave the ash pan or fuel door open in an attempt to regulate the fire. This will overheat the furnace and void the warranty.
- Do not connect this unit to a chimney flue serving another appliance.
- Refer to nameplate on furnace for additional information.

### WARNING: RISK OF FIRE

- DO NOT operate with flue draft exceeding .08 water column inches (19.9 Pa).
- DO NOT store fuel or other combustible materials within marked installation clearances.
- Inspect and clean flues and chimney regularly.
- DO NOT operate your furnace with the fuel door or ash door open.

DANGER: Risk of Fire and Explosion. Do not burn garbage, gasoline, naphtha, engine oil, or other flammable liquids/inappropriate materials.

## Do Not Burn:

- Garbage;
- Lawn clippings or yard waste;
- Materials containing rubber, including tires;
- Materials containing plastic;
- Waste petroleum products, paints or paint thinners, or asphalt products;
- Materials containing asbestos;
- Construction or demolition debris;
- Railroad ties or pressure-treated wood;
- Manure or animal remains;
- Salt water driftwood or other previously salt water saturated materials;
- Unseasoned wood; or
- Paper products, cardboard, plywood, or particleboard. The prohibition against burning these materials does not prohibit the use of fire starters made from paper, cardboard, saw dust, wax and similar substances for the purpose of starting a fire in a wood heater.

Burning prohibited materials may result in release of toxic fumes or render the heater ineffective and cause smoke.

Ground furnace to grounding rod and leg of furnace!

Connect the 10 inch starter collar to the heat supply vent of the furnace. Connect the 12 inch starter collar to the cold air return on the back of the blower housing cover.

## Hot Air Duct and Cold Air Return Installation:

Included with your Shelter Furnace:

- One 10 inch starter collar
- One 12 inch starter collar

If using 10 inch insulated flex hot air duct, it is for indoor use only. Outside the house, you must use 10 inch galvanized pipe, wrapped with weatherproof UV-jacketed insulation for protection from the sun's UV rays. The 12 inch return air may be galvanized pipe. The 12 inch return air must be attached to the home so as not to pressurize the home. The warm air supply duct should be constructed of materials with a minimum temperature rating of 250° Fahrenheit.

NEVER reduce the 10 inch hot air or 12 inch return air, as this will affect the air flow and the furnace will not operate properly.

NEVER draw cold outside air into the blower housing. By doing so, the furnace's heat chamber will not reach the necessary temperature to heat the home.

The duct work should be designed so the external static pressure does not exceed .02 water column inches, while developing air velocities of 600 feet to 1,000 feet per minute in the main trunk duct and 400 feet to 600 feet per minute at the registers. The heat outlet should never be less than 10 inches round or 79 square inches.

The Shelter Furnace must be installed with a cold air return system. The system must be a minimum of 12 inches to readily transfer the cold air back to the furnace. If desired, a cold air filter box may be constructed with a minimum opening of 225 square inches.

A basement window is an excellent location for running the hot air duct vent as well as the vent for the cold air return. The cold air return is an integral part of the system and must be used when installing the furnace. Failure to use cold air return will pressurize the home causing the furnace to not work properly. If a basement window is not available, you may access the home through a window, wall, or crawl space for both the plenum and air return.

## **Burying Ductwork:**

DO NOT BURY FLEXIBLE DUCT.

To bury the ductwork, use schedule 40 or 80 PVC or black plastic dual wall culvert pipe with smooth inner walls. Dig a trench to accommodate both the heat duct and the return air duct. The trench must be a minimum of 24 inches deep. To further ensure efficiency, minimize heat loss, and prevent moisture formation, line the trench with 1 inch pink Styrofoam insulation sheeting on the sides and bottom of the trench. The duct run should not exceed 25 feet. If the run exceeds 25 feet, you run the risk of reducing the furnace's efficiency and airflow.

DO NOT USE FLEXIBLE HOT AIR DUCT INSIDE PVC OR CULVERT PIPE.

ALWAYS KEEP YOUR WOOD COVERED YEAR ROUND. DRY WOOD WILL PRODUCE MORE BTU OUTPUT AND A LONGER BURN TIME.

The diagram below shows typical installations through a basement window, crawl space, or wall. Notice that the heat duct and return air duct do not contain any 90° elbows. The use of 45° or less is advised for proper air delivery.

IF 10 INCH FLEX DUCT IS USED, IT MUST NOT BE EXPOSED TO THE OUTDOORS. IT IS FOR INDOOR USE ONLY.

**WARNING: RISK OF FIRE! DO NOT USE ANYTHING OTHER THAN 250° F-RATED FLEX DUCT!**

**IMPORTANT: FOR TECHNICAL SUPPORT OR CUSTOMER SERVICE ISSUES, DO NOT RETURN TO THE STORE, CALL STORE AT 1-800-875-4788.**

## **TYPES OF INSTALLATIONS:**

Your Shelter Furnace is designed to be a supplemental or central heating source for your home. This wood burning furnace may be installed in parallel with a properly operating electric, gas, or oil-fired central furnace that is listed or certified in accordance with a nationally recognized safety standard within installation clearances as specified on the Shelter Furnace nameplate. When in a parallel installation the static pressure of the central furnace plenum may not exceed .15 water column inches, and the maximum setting on central furnace limit switch is 182° F. With the SF4200 wood burning furnace in an "Interconnection Arrangement" your Shelter Furnace should be upstream from the central furnace. The Shelter Furnace warm air supply should never be connected to the return air for the central furnace. A QUALIFIED INSTALLER SHOULD PERFORM INSTALLATION.

Smoke detectors and carbon monoxide monitors should be installed on all levels of your home.

## **CENTRAL DUCT CONNECTIONS:**

A qualified professional should do the installation. Maximum run should be 25 feet. A duct run in excess of 25 feet will greatly restrict the air flow and heat output, therefore is not recommended. When connecting the Shelter Furnace to a central duct system, avoid 90° elbows. As with any furnace, the more turns and branches in the ducting limit the airflow delivery. DO NOT USE FLEX DUCT OUTSIDE.

Run 10 inch insulated galvanized hot air duct from the outside furnace through a window or wall of the house. Once inside, you may use 250° Fahrenheit rated insulated flexible hot air duct to connect the central duct system for the home. When using flexible duct inside the home, it must be pulled tight with no offsets or elbows to prevent turbulence and slowdown airflow. Connect the duct with a 45° elbow or at an angle so the hot air from the Shelter Furnace is delivered downstream. This will ensure proper airflow into the duct system. Avoid delivering the hot air through the air conditioning coil, as this will cause an obstruction, reducing the amount of heat output. DO NOT REDUCE THE SIZE OF THE HOT AIR DUCT. As with any furnace, longer runs and more turns and branches in the ducting greatly reduce the airflow and heat output. Use of 90° elbows is not recommended.

The 12 inch cold air return duct must run to the house to prevent pressurization of the home. Failure to connect the cold air return will cause the furnace not to operate. NEVER REDUCE THE SIZE OF THE RETURN. Reducing the size of the cold air return will restrict the hot air flow and put excess pressure on the blower motor. You may terminate the cold air return where you enter the house. This will provide adequate circulation within the home. See diagram.

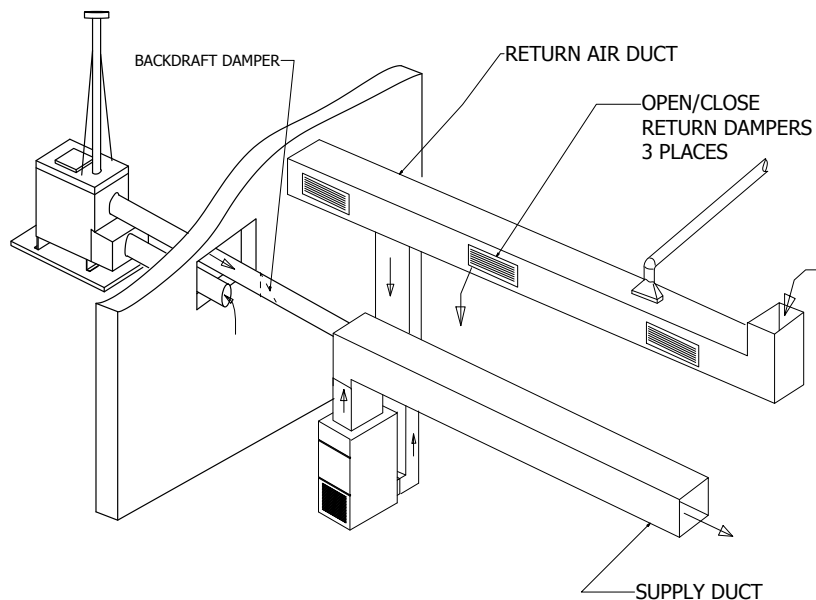

## **MOBILE HOME DOWN DRAFT FURNACE CONNECTIONS:**

A qualified professional should do the installation. Maximum duct run is 25 feet, a duct run in excess of 25 feet will greatly restrict the air flow and heat output and is not recommended. Both the hot air duct and the cold air return duct may be accessed through the floor in a mobile or modular home. In a mobile home with a down draft furnace, do not attach the hot air duct from the Shelter Furnace to the hot air plenum, doing so will cause the heat to

rise through the central furnace instead of going through the duct work. Split the hot air supply for the Shelter Furnace by using a "Y" and install one branch into each of the hot air ducts. Be sure both are pointing downstream. See diagram.

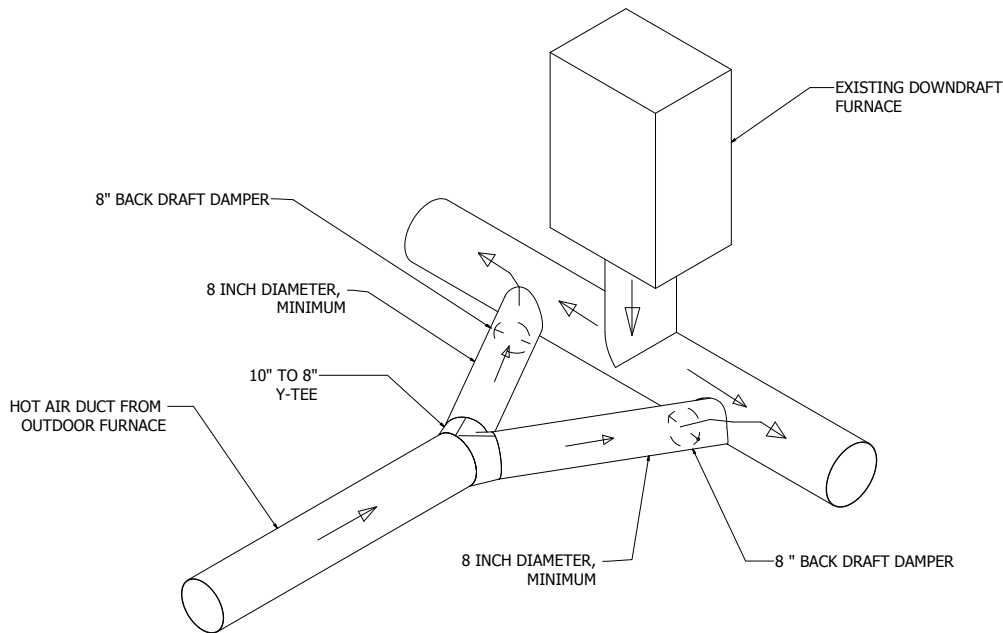

**NO DUCT WORK INSTALLATION CONNECTION:**

A qualified professional should do the installation. Cold air return must be installed in all cases, even those without ductwork. When there is no duct system to connect to the hot air flex duct, keep in mind:

- You must separate the hot air duct from the cold air return. Ideally, locate each at opposite ends of the home. If you don't, the air will not flow evenly throughout the home. This method will work well on homes built on concrete slabs and help create a good airflow.
- In homes with a basement, you may run the hot air duct into the basement and pull the cold air return from the main floor, this will create a perfect air flow, since hot air rises. The cold air return must be connected, even if the home does not have ductwork. If you don't connect the cold air return, the furnace will not be able to heat the home. See diagram.

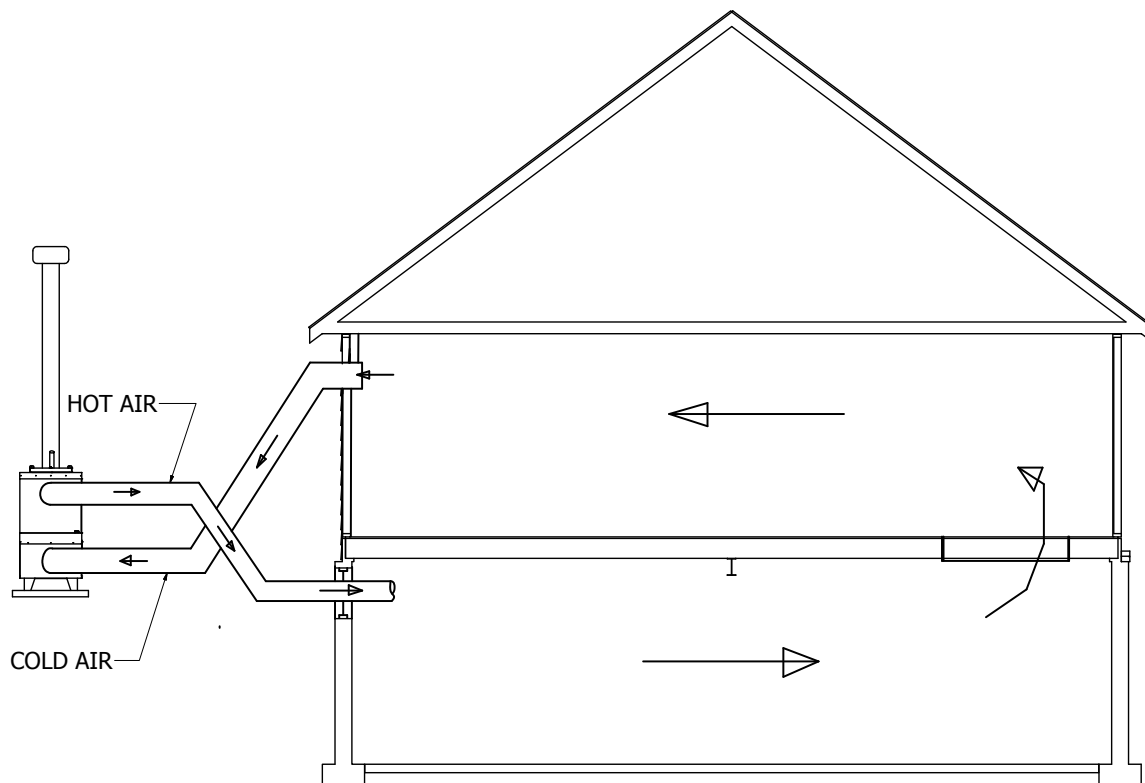

Outside Combustion air may be necessary for an indoor installation if:

- The solid-fuel-fired appliance does not draw steadily, smells, experiences smoke rollout, burns poorly, or back-drafts whether or not there is combustion present. Opening a window slightly on a calm day alleviates these symptoms.
- The house is equipped with a well-sealed vapor barrier and tight fitting windows, and/or has any powered devices, which exhaust house air.
- There is excessive condensation on windows in the winter.
- A ventilation system is installed in the house.

CAUTION: HOT SURFACES. KEEP CHILDREN AWAY. DO NOT TOUCH DURING OPERATION.

## **BURN WOOD ONLY!**

### **General Operation:**

---

#### **First Fire:**

Set the wall thermostat to 90°F. Make sure switch on the wall thermostat is in the HEAT position.

**Place several crumpled newspapers on the grate with some dry kindling layered on top of the papers, then ignite the newspaper. When the kindling is burning, add several small pieces of wood, allow wood to fully ignite. After about 20 minutes the fire should be established, allowing you to add more wood – do not overload which would smother the fire. Add more wood slowly, so the flames have time to engulf the fresh wood. Once the fire is burning and there is a glowing ember bed, set the wall thermostat to the desired home temperature.**

Do not over-fire the furnace. Over-firing by overloading/over fueling the furnace causes the metal to superheat and expand, then cool rapidly, which causes cracking, therefore voiding the warranty. Over-firing or abuse can easily be determined upon inspection.

It will take about 40 minutes to establish a bed of hot embers. **Once you have achieved the hot ember bed, add larger pieces of firewood.** Finally adjust the wall thermostat to a comfortable setting.

**NOTE:** Your new Shelter Furnace is capable of producing a very high BTU output. Do not fuel your furnace to capacity upon initial firing. It's recommended that you become thoroughly familiar with your Shelter Furnace before operating at full capacity.

The new steel and metal components of the furnace have a protective coating or paint on the surface which could produce an odor during the break in period. Adequate ventilation within the home and furnace room or area is recommended during the initial firing and break in period to accommodate this possibility. Your new Shelter Furnace is classified as having airtight construction. This type of design should enable you to experience an average burn time between 8 and 12 hours per full load of fuel (dry, seasoned hardwood). However, abnormally cold weather may reduce the burn time somewhat, but if your burn cycle is significantly less, for instance, 2 to 4 hours, you are over-firing your furnace. This type of occurrence is usually symptomatic of heat demands in excess of furnace capacity. Contact an authorized professional to determine if your Shelter Furnace has been improperly sized for your home. The heat output range, according to B415.1-10 testing, is 25,000 to 75,000 BTUs per hour.

#### **Loading Wood:**

When opening the fuel door during operation, always wait 10 seconds after releasing the first latch, then open the door the rest of the way. The dual latch system has been incorporated as a safety feature, designed to reduce the possibility of gaseous ignition. Laboratory testing has determined that when incomplete combustion occurs the partially spent fuel sometimes concentrates large amounts of potentially hazardous gases within the fire chamber. If the door is opened suddenly under these conditions, the oxygen may combine with these gases and cause ignition referred to as "back flash." Use EXTREME CAUTION when opening the fuel door.

When reloading the furnace, spread embers evenly over the grate. Place smaller pieces of wood on the hot embers and layer larger pieces on top of them. **Finally, due to the wide variety of temperature ranges during the winter, you may experience periods when it is not necessary to fully load the fire chamber in order to maintain an overnight burn.** Your Shelter Furnace will operate at the highest efficiency by adding fuel in amounts needed to maintain comfortable temperatures in your home.

**IMPORTANT: FOR TECHNICAL SUPPORT OR CUSTOMER SERVICE ISSUES, DO NOT RETURN TO THE STORE (THE STORE MAY NOT HAVE REPLACEMENT PARTS), CALL 1-800-875-4788.**

## **BURN WOOD ONLY!**

### **Fuel Recommendations:**

For the SF4200 model, heat resistant gloves are recommended when loading the furnace. **Only use dry, seasoned hardwoods in your Shelter Furnace rather than high resin woods such as pine. Firewood should be cut at least one full season prior to the time of its intended use for optimum heat output. Firewood should be stacked to provide a free flow of air between the logs; this allows the wood to season faster. If wood is stored outdoors, it should be completely covered year round to protect it from moisture and exposure to the elements.** Use extreme caution when opening the ash drawer and fuel door during operation, temperatures can exceed 300° F. Wait at least 10 seconds after releasing the first latch, then proceed to the fully open position. The dual latch system has been incorporated as a safety feature, which was designed to reduce the possibility of gaseous ignition. Heat resistant gloves are recommended when opening the fuel door or emptying the ash pan.

This wood heater needs periodic inspection and repair for proper operation. If you observe excessive smoke, check to be sure you are burning properly seasoned cordwood and that there are no gaps in the gaskets on the door of the unit. When it becomes necessary to replace the gaskets:

- Order part number FCGSKT58 (fuel door) and/or FCGSKT12 (ash door)
- Remove old gasket
- Install new gasket in gasket channel of door
- Cut off excess gasket, ensure that there is no gap where the ends of the gasket material meet

### **DISPOSAL OF ASHES:**

Heat resistant gloves are recommended. In order to remove ashes from your Shelter Furnace, slide the ash pan to the rear of the furnace. Remove the ash pan from the furnace and dump the ashes into a metal container with a tight fitting lid. The closed container of ashes should be placed on a non-combustible floor or on the ground, well away from all combustible materials, pending final disposal. If the ashes are disposed of by burial in soil or otherwise locally dispersed, they should be retained in the closed metal container until all cinders have thoroughly cooled. **Remove the ashes from your Shelter Furnace at least once a day, or as often as necessary to ensure the ashes do not accumulate to the height of the grates.** If ash build-up occurs at grate level, it will cause premature failure of the grate system, voiding the warranty on the grates. Unacceptably high temperatures will result because the ashes have restricted the flow of cooling air beneath the grates. This flow of air was designed to not only cool the grates, but to also provide warmed air for better combustion. If the ash level is improperly maintained the firebox will be starved of combustion air, greatly reducing the efficiency and heat output of your Shelter Furnace.

**ALWAYS KEEP YOUR WOOD COVERED YEAR ROUND. DRY WOOD WILL PRODUCE A HIGHER BTU OUTPUT AND A LONGER BURN TIME.**

### **HEAT DUMP AND FUSE LINK SYSTEM:**

The Shelter Furnace has a patented automatic safety feature, the Heat Dump Release System. In the case of a power failure, the heat dump release will open the spring-loaded lid when the internal furnace temperature reaches 370° F. The heat sensitive fuse link, located within the top of the heat chamber, causes the lid to open, allowing the excess heat to escape. This safety feature is designed to activate before any extreme heat can damage the furnace.

In the case of a power failure, connect your Shelter Furnace to a generator immediately. If the heat dump release lid should open, do not continue to burn the furnace. **DO NOT UNPLUG THE FURNACE.** Close the draft dampers and set the wall thermostat to the lowest possible temperature. **DO NOT** add fuel, which will allow the fire to die. After the electricity is restored, replace the fuse link before resuming normal operation.

**REPLACING THE FUSE LINK:** Remove the hex nut on top of the release lid and pull the bolt down through the lid. Remove the separated fuse link pieces and connect the new fuse link to the shaft inside the furnace heat chamber. Connect the other end of the fuse link to the bolt that goes through the lid. Feed the bolt through the lid and replace the hex nut onto the bolt on top of the lid. As a precaution, always have a replacement fuse link on hand.

**WARNING:** Never disengage the patented Heat Dump Fuse Link feature. This will void all warranties. Never put anything on top of the release lid. The area must be kept free of any obstructions. A visual inspection by factory personnel can easily determine if the proper steps were taken if a furnace over-heats. If the furnace is found to be deliberately improperly used, all warranties will be void.

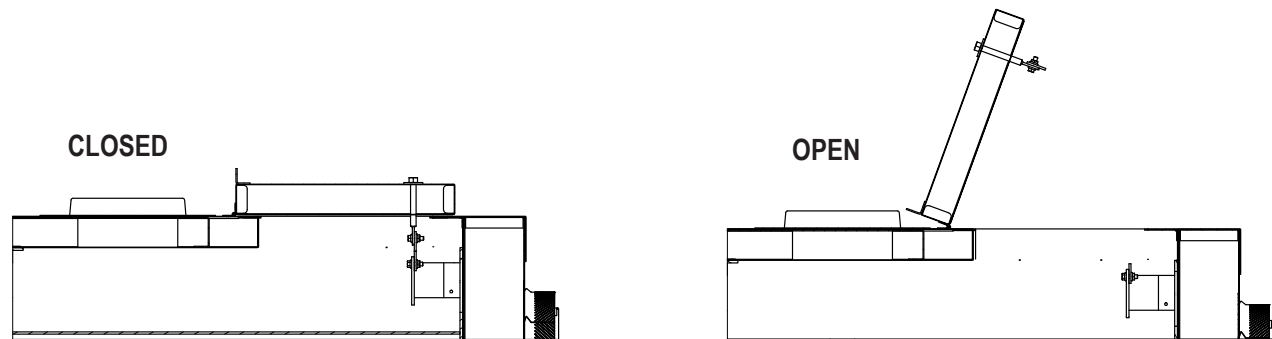

**To order a replacement Fuse Link (Part # FCFL370): call 1-800-875-4788.  
One replacement fuse link was included in the hardware pack for your furnace.**

### **Draft Blower:**

The draft blower plays an important role in the operation of your Shelter Furnace. When the wall thermostat calls for heat, the draft motor turns on and supplies fresh air into the firebox producing a hotter fire, which in turn provides more heat in the heat chamber. The heat is then sent through the duct system throughout your home. When the wall thermostat temperature is met, the draft blower shuts off until the thermostat calls for heat, beginning the cycle again. The draft blower has a slide cover located on the side of the motor that is factory preset, with an opening of approximately 3/8". The cover should be fully closed only when there is a power failure and electricity is lost. With the cover closed, no air is introduced into the firebox, then the fire dies, preventing the furnace from possible overheating and damage.

### **Creosote Formation and Need for Removal:**

**When wood is burned slowly, it produces compounds in exhaust smoke, which combine with expelled moisture to form creosote. The creosote vapors condense in the relatively cooled chimney flue of a slow burning fire. As a result, creosote residue accumulates on the flue lining.** When ignited, this creosote makes an extremely dangerous fire in the chimney. The chimney connector and the chimney should be inspected at least twice monthly during the heating season to determine if a creosote build-up has occurred. If creosote has accumulated it should be removed to reduce risk of a chimney fire.

## **Creosote Prevention:**

**To help prevent the formation of creosote within the flue, ALWAYS BURN DRY, SEASONED WOOD. Dry wood burns hotter, allowing flue gases to maintain temperatures above 212°F which should reduce the formation of creosote in the chimney.** If the flue gas temperature falls below 212°F, condensation occurs causing creosote formation and accumulation within the chimney.

As an added precaution, periodic chimney inspections are recommended during the heating season to determine if creosote formation has occurred. For safety and efficiency, it is recommended that the chimney system be inspected and cleaned prior to each heating season.

## **Power Failure:**

In case of power failure, to prevent your Shelter Furnace from over-heating and causing damage to the electrical components, follow these steps:

- Make sure the ash door is closed.
- Close the slide cover on the side of the draft motor.
- Do NOT add more fuel to the firebox.

**There is no warranty on electrical components damaged due to power failure.**

### **CAUTION:**

- INSPECT FLUE PIPES, FIREBOX, STOVE PIPE, CHIMNEY AND DRAFT BLOWER JOINTS AND SEALS REGULARLY TO ENSURE THAT SMOKE AND FLUE GASES ARE NOT DRAWING INTO, AND CIRCULATED BY THE AIR-CIRCULATION SYSTEM.
- CLEANING OF THE FIREBOX, STOVE PIPE, CHIMNEY AND DRAFT BLOWER (IF USED), IS ESPECIALLY IMPORTANT AT THE END OF THE HEATING SEASON TO MINIMIZE CORROSION DURING THE SUMMER MONTHS CAUSED BY THE ACCUMULATED ASH.
- Do not use chemicals to start the fire.
- Do not burn garbage, gasoline, naphtha, engine oil, or other flammable liquids/inappropriate materials.

## **Maintaining Your Furnace:**

At the beginning of each heating season, take time to thoroughly check your furnace and chimney system. Make sure there are no leaks where the metal panels are joined or at the caulk lines. Should you find a leak, high-temp silicone will correct the problem. Check the door for signs of rust. Should rust develop, lightly sand, with sandpaper or steel wool, the surface and follow up with black, high temperature paint to keep the door looking new. Check the gaskets, if they are frayed and burnt, replace the gasket. Check the firebricks for breakage or crumbling, and replace as needed. Check the chimney pipe for signs of creosote formation, if you find creosote, thoroughly clean the chimney system replacing the chimney cap securely so rain or snow does not run down the chimney into the firebox. If the cap is removed for any length of time when the furnace is not in use, cover the pipe so no moisture gets into the firebox. Check the chimney cap for holes or loosened connections, replace and secure as necessary. Check the grates for signs of wear and replace as needed. Check the heat duct and cold air return to be sure they have not become loose or been damaged. If so, tighten or replace as needed. Check ductwork for any air leaks. Remove any accumulated ashes at the end of the season. By following these procedures, your furnace will provide many years of trouble-free service. Door seals should be checked annually to make sure that a good seal will ensure complete combustion and high efficiency.

**IMPORTANT: FOR TECHNICAL SUPPORT OR CUSTOMER SERVICE ISSUES, DO NOT RETURN TO THE STORE (THE STORE MAY NOT HAVE REPLACEMENT PARTS), CALL 1-800-875-4788.**

## **ALWAYS:**

- Locate the Shelter Furnace on a level, solid, non-combustible surface.
- Follow local codes concerning installation requirements.
- Connect power cord to a grounded 110 outlet.
- Connect cold air return to the house.
- Use Class "A" HT2100 All Fuel 6 inch chimney.
- Follow guidelines within this manual regarding burn procedures.
- Operate furnace with fuel door and ash door closed.
- Inspect the furnace several times a year to ensure furnace caulking is adequate.
- Inspect chimney pipe for creosote formation.
- **Use dry, seasoned hardwood and always keep your wood covered.**
- Have access to a backup generator in case of power failure, minimum of 2000 watts.

## **NEVER:**

- Allow anyone to operate the furnace that is not familiar with the unit.
- Operate with fuel door or ash door open.
- Use gasoline, oil, or any other flammable liquid to start or maintain the fire.
- Burn garbage, plastic, wood containing glue or wood that has been treated with chemical preservatives.
- Operate your furnace without a backup power supply, or generator.
- Fuel your furnace with wet, unseasoned wood.
- Use 90° elbows when running ductwork.
- Operate the furnace without the chimney attached.
- Alter the furnace in any way.

**CAUTION: HOT SURFACES. KEEP CHILDREN AWAY. DO NOT TOUCH DURING OPERATION.**

## **CAUTION:**

- INSPECT FLUE PIPES, JOINTS AND SEALS REGULARLY TO ENSURE THAT SMOKE AND FLUE GASES ARE NOT DRAWING INTO, AND ARE NOT BEING CIRCULATED BY THE AIR-CIRCULATION SYSTEM.
- CLEANING OF THE FIREBOX, STOVE PIPE, AND CHIMNEY, IS ESPECIALLY IMPORTANT AT THE END OF THE HEATING SEASON TO MINIMIZE CORROSION DURING THE SUMMER MONTHS CAUSED BY THE ACCUMULATED ASH.
- Never use chemicals or gasoline to start or maintain your fire.
- Do not burn oil, garbage, trash, plastic, or any fuel other than wood in your furnace. Doing so will void the warranty.

## **WARNING: – RISK OF FIRE**

- DO NOT operate with flue draft exceeding .08 water column inches (19.9 Pa).
- DO NOT store fuel or other combustible materials within marked installation clearances.
- Inspect and clean flues and chimney regularly.
- DO NOT operate your furnace with the fuel door or ash door open.

## **Canadian Requirements for Supplemental/Add-On Furnaces**

- DO NOT USE DUCT ELBOWS HAVING AN INSIDE RADIUS OF LESS THAN 6 inches (150mm) ON OIL, ELECTRIC, OR GAS FURNACES.
- DO NOT CONNECT TO A DOWNFLOW FURNACE.
- DO NOT CONNECT DUCTWORK SO THAT A REVERSE FLOW IS POSSIBLE.
- OPERATE THE GAS/OIL/ELECTRIC/ FURNACE PERIODICALLY TO ENSURE THAT IT WILL OPERATE SATISFACTORILY WHEN NEEDED.
- CERTIFIED FOR INSTALLATION WITH APPROPRIATE DUCTWORK CONFIGURATIONS ONLY.

- DO NOT RELOCATE OR BYPASS ANY OF THE SAFETY CONTROLS IN THE ORIGINAL GAS/OIL/ELECTRIC FURNACE INSTALLATION.
- DO NOT CONNECT TO ANY GAS FURNACE THAT HAS NOT BEEN CERTIFIED INITIALLY AS COMPLYING WITH CAN/CGA-2.3.
- THE OPERATION OF THE GAS FURNACE MUST BE VERIFIED FOR ACCEPTABLE OPERATION BEFORE AND AFTER INSTALLATION OF THE ADD-ON APPLIANCE BY A GAS FITTER WHO IS RECOGNIZED BY THE REGULATORY AUTHORITY.
- DO NOT CONNECT TO ANY GAS FURNACE THAT IS NOT EQUIPPED WITH AN AIR-CIRCULATION BLOWER, OR TO A CHIMNEY OR VENT SERVICING A GAS FURNACE OR GAS APPLIANCE.

The add-on unit should only be installed on a furnace duct system and chimney that are in good operating condition.

If exhaust fans are installed in the storage area they should not create negative pressures in the room where the solid fuel-burning appliance is located.

On a belt-driven system, blower and motor pulleys may be changed but the electrical current flowing through the motor cannot exceed the nameplate rating. On a direct-drive system, the motor should not be changed, however, the speed of the motor may be increased. The blower cannot be changed. This equipment should be installed, acceptable to regulatory authority, by experienced licensed personnel.

Establish a routine for the storage of fuel, care of the appliance, and firing techniques.

Check daily for creosote build-up until experience shows how often cleaning is necessary.

Be aware that the hotter the fire, the less creosote is deposited, and that weekly cleaning may be necessary in mild weather, even though monthly cleaning may be enough in the coldest months. A small intense fire is preferable to a large smoldering fire to reduce the amount of creosote deposition.

The installation should comply with requirements of CAN/CSA-B365, and changes to the installation should comply with CSA-B139 (for oil-fired), C22.1 (for electric), or CAN/CGA-B149.1 or CAN/CGA-B149.2 (for gas-fired).

## Grate and Fire Brick Diagrams

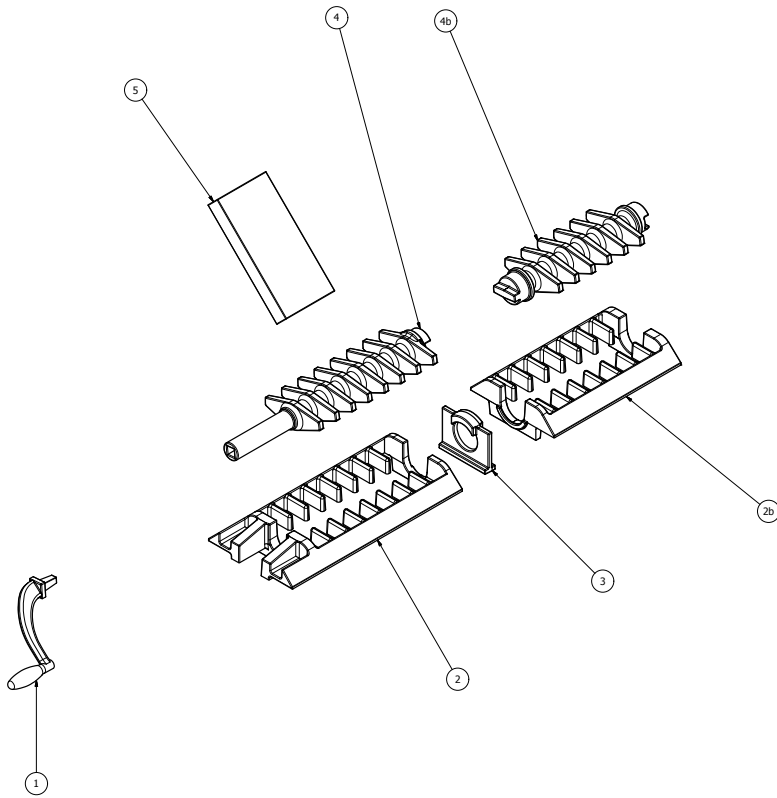

SF4200 PARTS LIST		
ITEM	QTY	PART DESCRIPTION
1	1	FC000 ROLLER GRATE HANDLE
2	1	ROLLER GRATE BASE
2b	1	ROLLER GRATE EXTENSION BASE
3	1	ROLLER GRATE SUPPORT
4	1	FC000 ROLLER GRATE
4b	1	FC000 ROLLER GRATE EXTENSION
5	12	FIRE BRICK

## Blower Motor Assembly Diagram

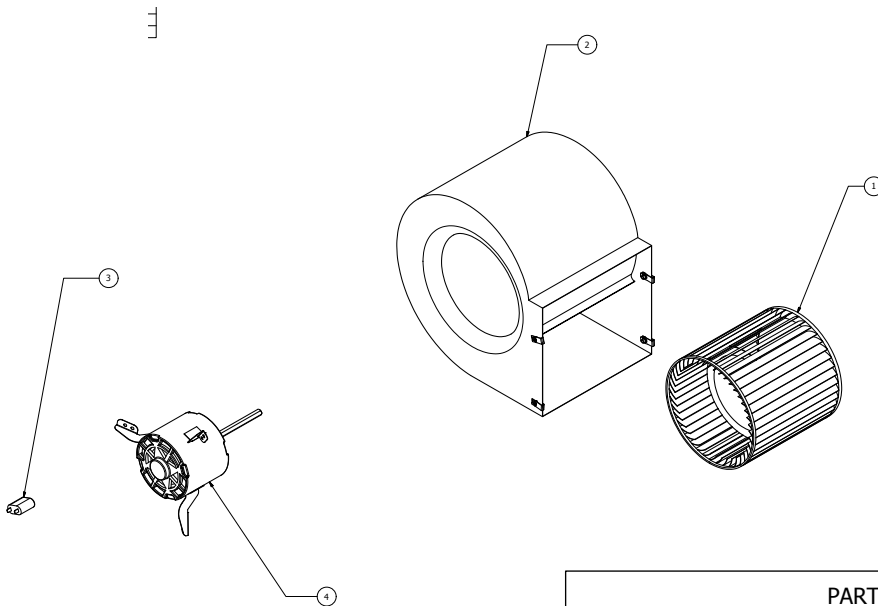

PARTS LIST		
ITEM	QTY	DESCRIPTION
1	1	BLOWER WHEEL
2	1	BLOWER HOUSING
3	1	MOTOR CAPACITOR
4	1	BLOWER MOTOR

# Wiring Diagram

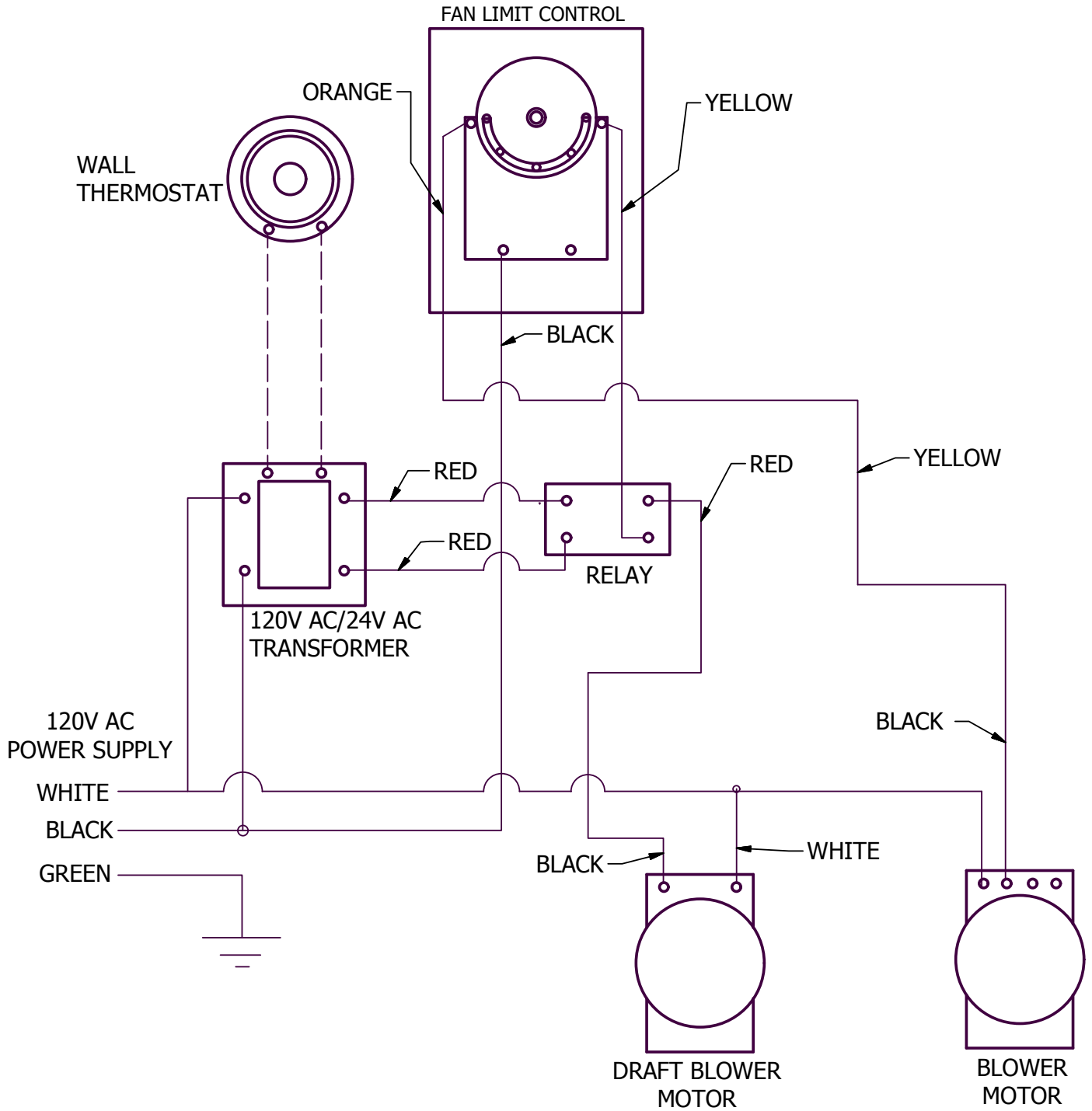

# Troubleshooting

## 1. Problem: Bugs found in wood.

### Possible Causes:

- Wood has rotted or has been laying around for an extended period of time.

### Remedies:

- Inspect the wood for obvious signs of insect infestation such as burrows or holes, avoid using if possible. Do not store wood indoors.

## 2. Problem: Home does not achieve comfortable temperature.

### Possible Causes:

- Improper ductwork connection to existing furnace.

### Remedies:

- Refer to information in the manual relating to the proper installation procedures or contact your local heating and cooling contractor.

- Improperly sized ducting.

- Refer to information in the manual relating to the proper ducting procedures or consult your local heating and cooling contractor.

- Excessive dirt accumulation in air filter.

- Check and replace filter.

- Poor chimney draw, resulting in the furnace not providing enough heat.

- Increase height of chimney (refer to "10/2 Rule" on page 4.) This will help the furnace to achieve more efficient and hotter temperatures.

- Inadequate insulation of the home.

- Provide additional insulation.

- Furnace size is inadequate for your home.

- Consult a professional to determine correct sizing.

- Slide cover on draft blower is "CLOSED."

- Open slide cover to an opening of approximately 3/8 inches.

- **Fueling furnace with wet or unseasoned wood.**

- **Completely avoid using if at all possible. If circumstances necessitate the use of wet or unseasoned wood, then fuel the furnace with smaller loads. This will cause the thermostat to call for heat more often, which will initiate the running of the draft blower. Consequently, the fires will be hotter, thereby reducing the accumulation of creosote.**

- Outside air is being pulled into the return air duct, reducing the heat output in the home..

- Inspect return air duct from the blower housing to the home, seal any openings with aluminum duct tape.

## 3. Problem: Heat dump lid on top of furnace has opened.

### Possible Causes:

- Power failure.

### Remedies:

- Use backup generator as power source immediately! Replace the heat sensitive fuse link.

- Furnace has over-heated and the heat release lid has opened.

- Correct the over-heating problem and restore power to the furnace. Replace the heat sensitive fuse link before firing the furnace again.

## 4. Problem: Draft blower will not run. NOTE: Verify that the wall thermostat is in the “HEAT” position, and make sure batteries are installed.

### Possible Causes:

- Defective wall thermostat.
- Wall thermostat is in the wrong position.
- Defective transformer relay center.
- Defective draft motor.
- Improper wiring.

### Remedies:

- This can be checked by turning the thermostat to a temperature setting that is higher than the temperature in your home. If the draft blower does not operate, the thermostat may be defective. Replace if necessary.
- Move switch on wall thermostat to the “HEAT” position.
- Replace transformer relay center.
- Replace draft motor.
- Review wiring diagram. If unit is wired correctly, seek professional assistance.

## 5. Problem: Circulation blower will not turn on.

### Possible Causes:

- Defective fan limit control.

### Remedies:

- Remove fan limit control cover and look for the word “Caution.” If it is upside down, replace fan limit.

## 6. Problem: Excessive dirt accumulation surrounding air registers in the home.

### Possible Causes:

- Furnace is not connected to return air duct and is discharging dirt throughout home.
- No filter in return air system.

### Remedies:

- Connect to return air duct system.
- Install filter and check frequently.

## 7. Problem: Circulation blower runs constantly. NOTE: Make sure the white button on fan limit control is pulled out and in the “auto” position.

### Possible Causes:

- “Off” setting on fan limit control is low.
- White button on fan limit control is pushed in.
- Defective fan limit.
- Improper wiring.
- Backdraft damper is in the “closed” position.

### Remedies:

- Remove cover on fan limit control and check for the proper setting. The point indicators should be set at 100° “Off” and 150° “On.” Do NOT attempt to adjust the fan limit by manually adjusting the temperature indicators on the dial.
- Pull white button out and the blower should stop.
- Check by moving “ON” and “OFF” point indicator to a temperature position where blower should turn off. If the blower continues to run, replace the fan limit.
- Review wiring diagram. If unit is wired correctly, seek professional assistance.
- Open backdraft damper.

## 8. Problem: Rapid accumulation of creosote in furnace and flue.

### Possible Causes:

- Use of high resin wood, such as pine.

- Under-firing the furnace has caused low flue gas temperature.

- Insufficient chimney draft.

- Using uninsulated stove pipe for the chimney.

- Improper connection in stove pipe causing air leakage or a structural defect in the chimney itself.

- Fire box not receiving adequate amount of oxygen.

### Remedies:

- Completely avoid using if at all possible. If hardwoods are not available, fuel the furnace with smaller loads. This will cause the thermostat to call for more heat more often, which will initiate the running of the draft blower. Consequently, the fires will be hotter, thereby reducing the accumulation of creosote.

- Install flue gas thermometer and maintain stack temperatures between 300° and 400° F.

- See #9.

- DANGER: Never use uninsulated stove pipe as chimney. Uninsulated pipe cannot be used as an outside flue because it causes rapid cooling of the stack gases, which causes them to condense as creosote on the inside of the flue.

- Inspect entire flue run, from the exhaust stack of the furnace to the termination cap. Repair as necessary.

- Chimney is not tall enough, see "10/2 Rule" on page 7.

## 9. Problem: Smoke from the fire chamber is puffing back through the forced draft motor.

### Possible Causes:

- Chimney is not high enough.

### Remedies:

- Chimney should be a minimum of 6 feet high or refer to "10/2 Rule," see page 7 for details.

## 10. Problem: Insufficient air flow from the heat registers.

### Possible Causes:

- Return air not connected to furnace from the house.

- Excessive duct run to the house.

- Air filter is dirty, restricting air flow.

- The use of 90° elbows in the duct run.

- The hot air supply is being short cycled back through the return instead of going down stream to the house.

- If using flex duct, it is not straight and pulled tight. A sagging line will cause swirling in the duct and reduce air flow.

### Remedies:

- Connect air to the home to circulate air flow.

- Reduce duct run by placing the furnace closer to the house.

- Replace air filter.

- Remove 90° elbows and replace with 45° elbows.

- Redirect the hot air supply to send it down the air duct supply line. You may install a back draft damper from the direction of the return air.

- Ensure the flex duct is pulled tight and straight with no snags. Always go into your main supply lines at a slant pointing down stream.

## 11. Problem: Circulation blower vibrates during operation.

### Possible Causes:

- Screw on squirrel cage is not tight.
- Balance weights on squirrel cage have become dislocated.
- Defective main bearings.
- Debris in blower wheel.

### Remedies:

- Check squirrel cage alignment and position so that it does not drag on the housing during rotation, then tighten the screw sufficiently to fasten the squirrel cage securely to the shaft.
- You may attempt to adjust the weights yourself to obtain an acceptable balance. If you are unsuccessful, contact your supplier.
- Return the blower to your supplier for replacement.
- Remove debris from wheel.

## 13. Problem: Odor detected in home during initial firing.

### Possible Causes:

- There is an oily film that remains on the steel after the manufacturing process. Firing the furnace has raised the temperature of the fire box to a level that is sufficient to vaporize the residue.

### Remedies:

- The odor should disappear after a few hours of usage.

## 14. Problem: Excessive smoke discharge from fuel door during reloading.

### Possible Causes:

- Insufficient draft.
- Obstructed chimney or clogged chimney cap.
- Creosote build-up.

### Remedies:

- See #9.
- See #16.
- See #8.

## 15. Problem: Draft blower runs constantly.

### Possible Causes:

- Defective wall thermostat.
- Defective transformer relay center.
- Home is not being supplied with a sufficient amount of heat to satisfy the wall thermostat.

### Remedies:

- This can be checked by turning the thermostat to a lower setting than the temperature in your home. If the draft blower continues to run, the thermostat may be defective. Replace if necessary.
- Replace transformer relay center.
- Have a professional determine the proper size furnace and insulation factor of your home.

## 16. Problem: Down draft on chimney caused by one or more of the following.

### Possible Causes:

- There is an obstruction outside chimney, such as a tree.
- Flue is located too close to the peak of the roof or does not rise above it to provide the proper draft.
- Flue is too close to another building.
- Obstruction in chimney.
- Excessive ash accumulation.

### Remedies:

- Remove obstruction.
- Increase chimney height.
- Increase chimney height.
- Check entire chimney system including stove pipe run. Utilize chimney cleaning device to remove any obstruction or foreign matter.
- Remove as necessary.

## 17. Problem: Flames discharging from fuel door during reloading.

### Possible Causes:

- Opening the door has provided additional oxygen which has ignited the accumulated gases from partially spent fuel.
- Insufficient natural draft or an obstruction in the flue system.
- Fire chamber filled to capacity with unburned fuel.

### Remedies:

- Always open the door cautiously and allow the safety latch system to perform its designed function, containing gases within the fire chamber.
- See #8, #9 and #16.
- Do not attempt to overload the furnace.

## 18. Problem: The air coming out of heat registers is not warm enough.

### Possible Causes:

- The chimney on the furnace is not tall enough which is affecting the efficiency of the furnace.
- Wood being used is not dry enough to produce higher BTU's.
- Outside air is being pulled through the return air duct, thus reducing the temperature of the heat supply.
- Fan limit control is not set to factory specifications.

### Remedies:

- Add additional sections of chimney to the flue to ensure compliance with the "10/2 Rule." See diagram on page 7.
- Use hardwood that is covered and protected from the weather for at least a year. Avoid using rotten or poor quality wood.
- Check the return duct and blower housing for holes and cracks, and seal with aluminum tape.
- Set fan limit to 150° as high limit, and 100° as the low limit.

## Warranty Information

---

### **CERTIFICATE OF LIMITED WARRANTY:**

**EXTENT OF COVERAGE:** This warranty covers Shelter Furnaces SF4200, sold in the United States and Canada. This warranty is void if the Shelter Furnace is not installed, maintained, and operated in accordance with the instructions in the owner's manual and local codes. Warranty is also null and void if the unit is used to burn materials for which the unit is not certified by the EPA. This warranty applies to the original purchaser/owner of the Shelter Furnace and is not transferable. Replacement or repair parts are warranted for the remaining period of the original warranty.

All warranty claims must include:

- Date of purchase
- Model and serial number
- Proof of purchase – dated invoice, bill of sale, cancelled check or payment record
- Name and address of the dealer where the unit was purchased

Shelter Furnace warrants the cast iron grates and firebox to be free of defects in material and workmanship for five years to the original purchaser. Intentional misuse or abuse causing burn through of the cast iron components voids all warranties. Over firing the furnace will cause the front face to crack and is not covered by the warranty. Furthermore, some cosmetic deterioration can be expected as the result of normal operation, therefore the physical appearance is not guaranteed to remain unchanged. The manufacturer warrants all electrical components for 1 year and the draft blower and distribution motor for 2 years. Please be advised that the firebrick and door gaskets are excluded from this warranty.

In order to exercise the aforementioned warranty, a certified professional must determine the appliance/part to be defective. He or she must submit a written statement to Shelter Furnace detailing an assessment of the problem. This assessment **MUST** be accompanied by substantiating proof of purchase (dated invoice, bill of sale, cancelled check, or payment record), model and serial number. Shelter Furnace will then authorize repair or replacement appropriate to the submitted claim. Shelter Furnace will not honor expenses incurred from any action that was not expressly consented to in writing. The owner is hereby notified that he or she will be obligated to assume liability for removal, reinstallation, shipping, and labor costs involved in servicing/repairing or replacing the part or unit. The merchandise in question must be shipped via **PREPAID FREIGHT** to Shelter Furnace. Shelter Furnace will return the repaired or replacement part to the purchaser on a **FREIGHT COLLECT** basis.

This warranty will be rendered null and void if this part/unit exhibits symptoms of obvious over-firing, deliberate abuse or negligence, improper installation, or is used for commercial purposes.

Finally, Shelter Furnace will not be responsible for any claim not stated in our warranty nor does any implied warranty extend beyond the limits stated above.

If you are unable to receive satisfactory service, please contact Shelter Furnace with all pertinent information including daytime phone number and a detailed description of the type of problem you are having. Shelter Furnace technical service will contact you as soon as possible. Call 1-800-875-4788 or mail information to: Shelter Furnace, 10950 Linpage Place, Saint Louis, MO 63132.

