

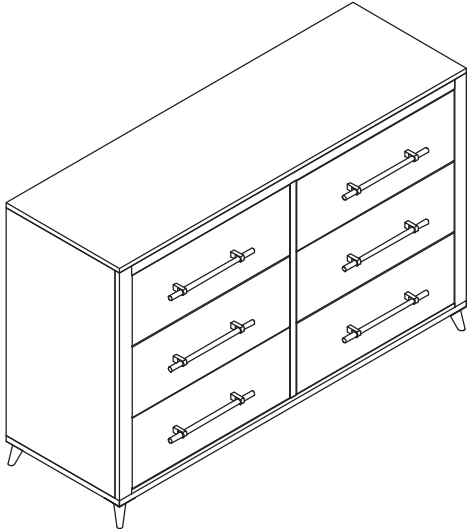

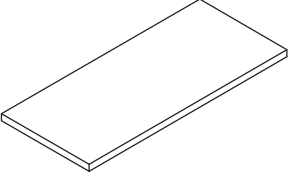

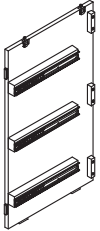

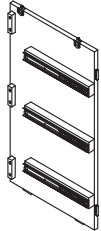
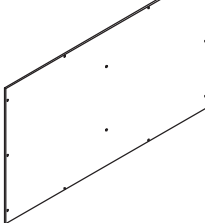
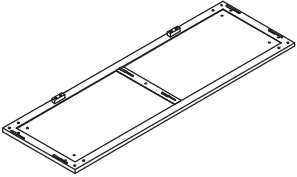
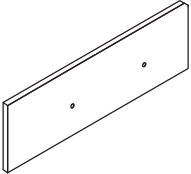
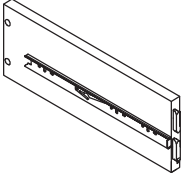
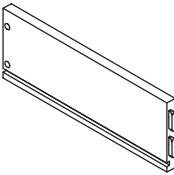
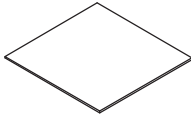
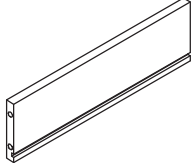
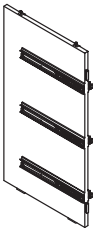
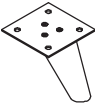

LAMINATE 6-DRAWER DRESSER - Series A

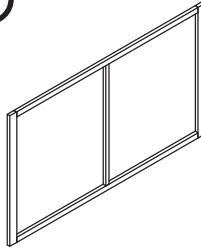
	<p>A Top Panel - 1 pc</p> 	<p>B Left Side Panel - 1 pc</p> 	<p>C Right Side Panel - 1 pc</p> 	<p>D Back Panel - 1 pc</p> 	<p>E Bottom Panel - 1 pc</p> 	
	<p>F Drawer Front - 6 pcs</p> 	<p>G Left Drawer Side - 6 pcs</p> 	<p>H Right Drawer Side - 6 pcs</p> 	<p>I Drawer Bottom Panel - 6 pcs</p> 	<p>J Drawer Back - 6 pcs</p> 	
	<p>K Center Panel - 1 pc</p> 	<p>L Legs - 4 pcs</p> 	<p>M Support Leg - 1 pc</p> 	<p>N Face Frame - 1 pc</p> 	<p>1 25mm Allen Bolt - 36 pcs</p> 	
	<p>2 Handle - 6 pcs</p> 	<p>3 Allen Key - 1 pc</p> 	<p>4 19 mm Handle Screw - 12 pcs</p> 	<p>5 12mm Allen Bolt - 16 pcs</p> 		

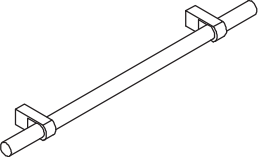
TOOLS NEEDED: Phillips Screwdriver



Step 1: Attach the legs (L) and support leg (M) to the bottom panel (E) using Allen bolts (5) and the Allen key (3).

Note: Make sure the mounting blocks are facing upward.

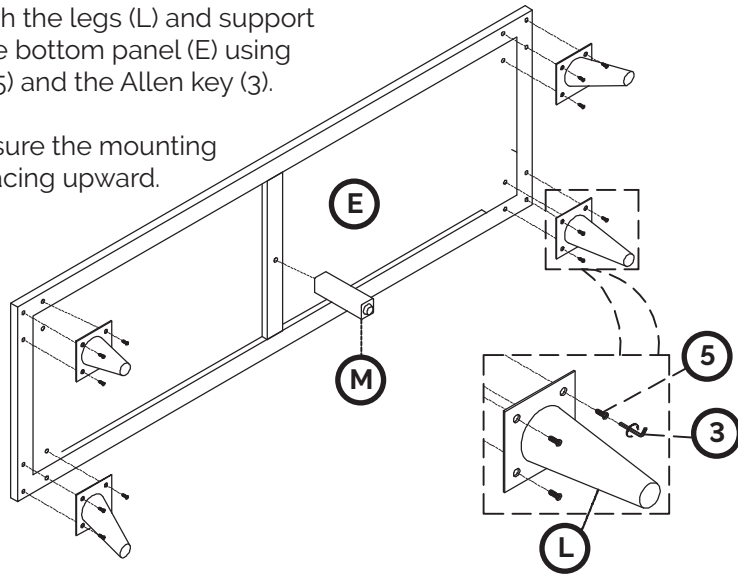

Step 2: Attach the left side panel (B), center panel (K), and right side panel (C) to the bottom panel (E) by placing the plastic pieces into the slots and sliding the side panels toward the front.

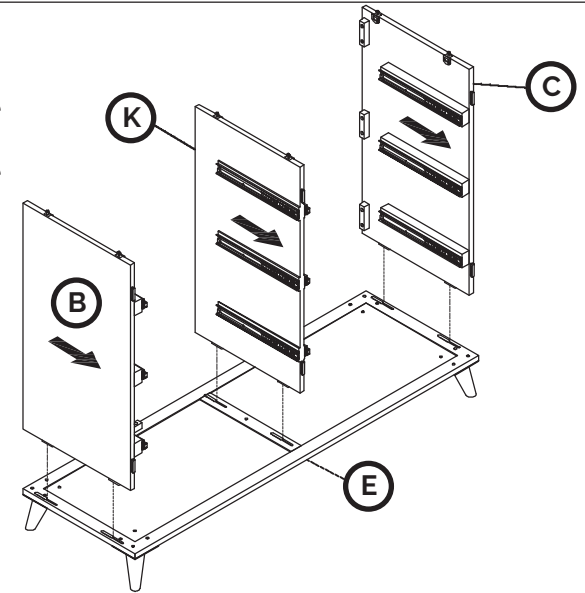

Step 3: Secure the face frame (N) to the center and side panels (B,C,K) by placing the plastic pieces into the slots and sliding the face frame (N) down.

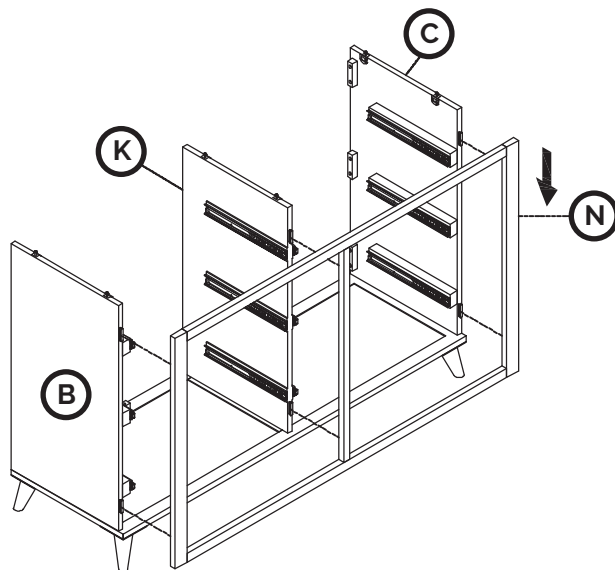

Step 4: Place the top panel (A) onto the side panels (B,C) and flip the levers on the side panels to the "closed" position.

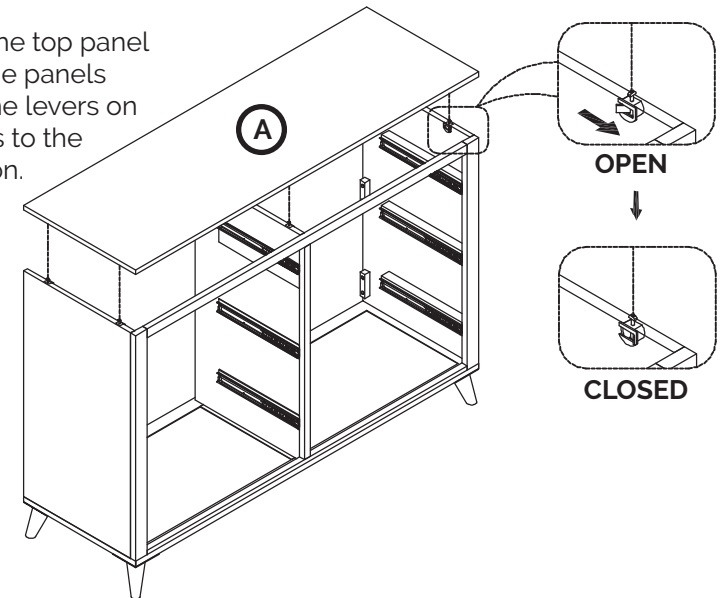

Step 5: Secure the back panel (D) to the mounting blocks using Allen bolts (1) and the Allen key (3).

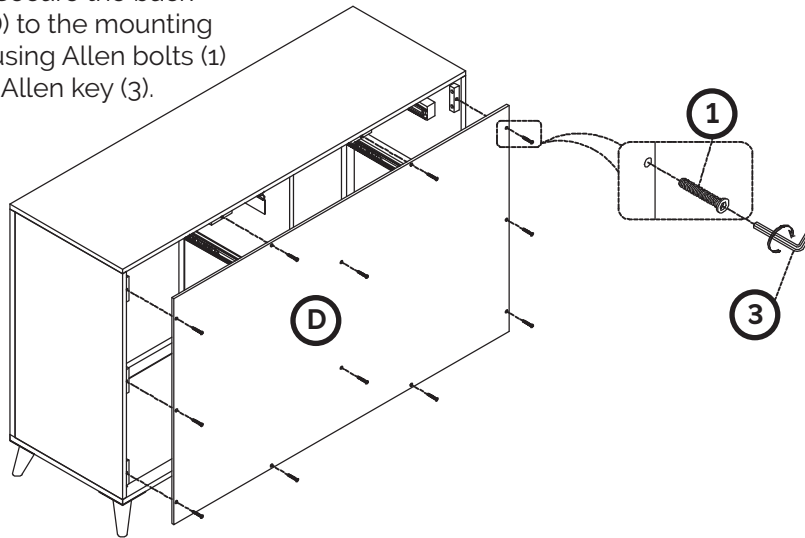

Step 6: Attach the left drawer side (G) and right drawer side (H) to the drawer front (F) by placing the plastic pieces into the slots and sliding the drawer front (F) down.

Note: Make sure the metal tracks are facing outward and the bottom panel groove is toward the bottom.

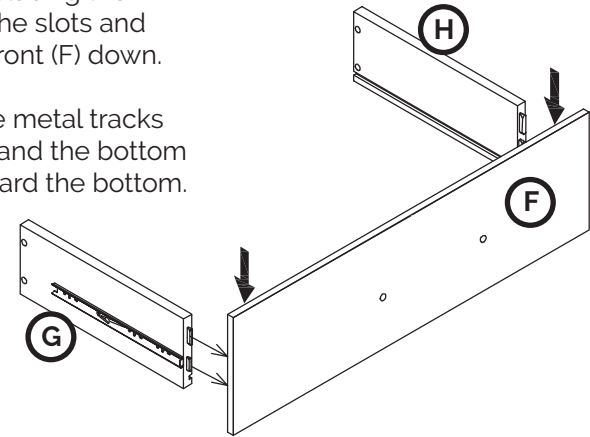

Step 7: Slide the drawer bottom panel (I) into place.

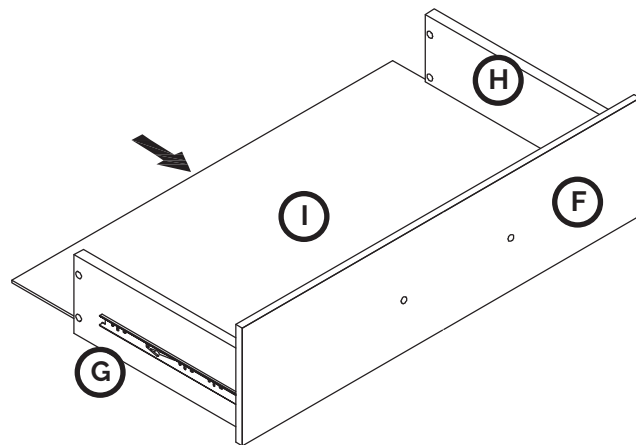

Step 8: Attach the drawer back (J) to the drawer sides (G,H) using Allen bolts (1) and the Allen key (3).

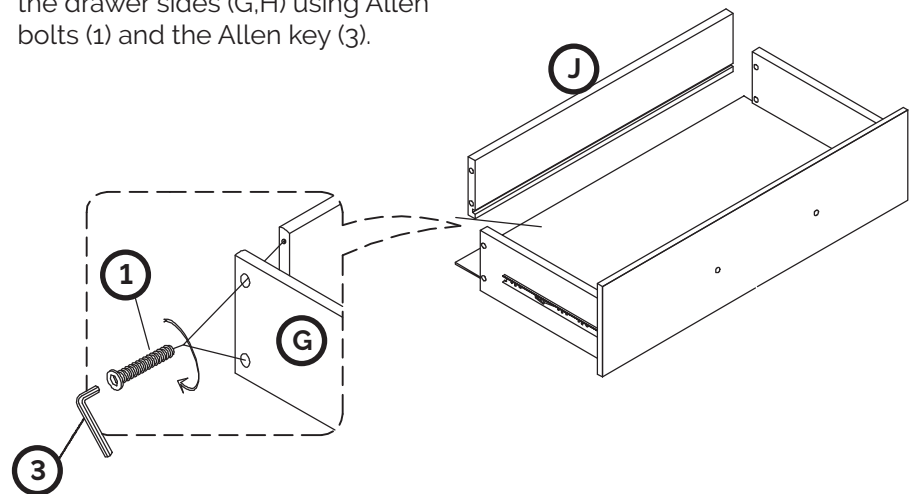

Step 9: Attach a handle (2) to the drawer front (F) using a screw (4) and Phillips screwdriver.

Repeat steps 6-9 for each drawer

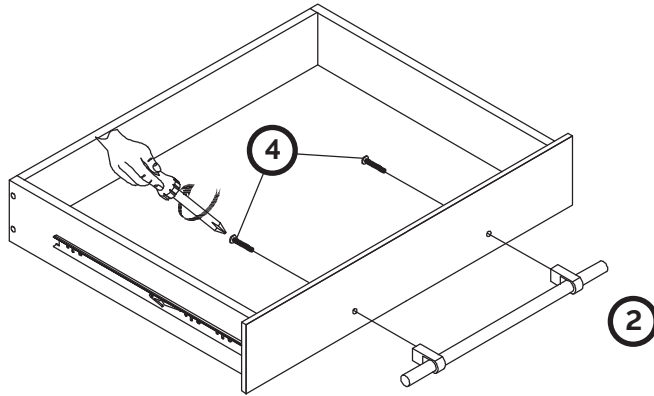

Step 10: Place drawers into the dresser frame on the metal tracks and slowly work the drawers into place until fully closed.

To remove the drawers, use the lever release. Pull the drawer out as far as possible, and you'll see a plastic lever on each side. Pull one lever up and push the other down to remove the drawer.

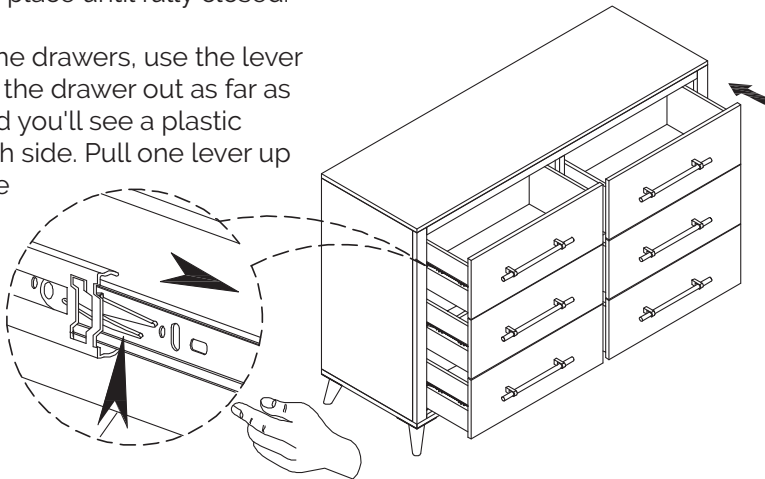

LIMITED 1-YEAR WARRANTY

WHAT IS COVERED

This warranty covers any defects in materials or workmanship, with the exceptions stated below.

HOW LONG COVERAGE LASTS

This warranty runs for one (1) year from the date of purchase.

WHAT IS NOT COVERED

The warranty applies only to the original purchaser and does not cover: (a) wear and tear; (b) improper maintenance, misuse, or alteration; (c) repair by unauthorized representatives; (d) damage resulting from transit or handling; or (e) transportation costs.

WHAT WE WILL DO

At our sole discretion we will repair, replace, or refund any product that proves to be defective in materials or workmanship.

HOW TO GET SERVICE







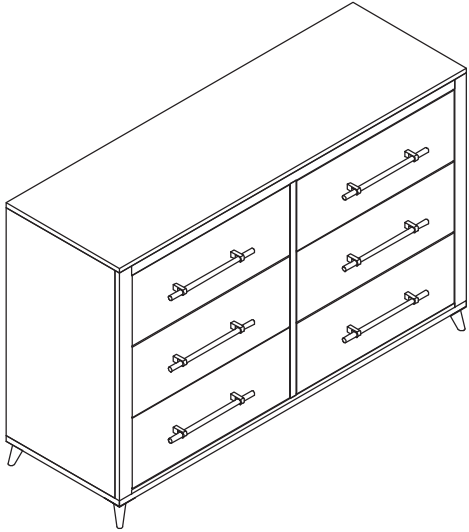
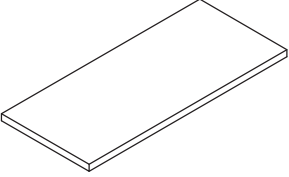
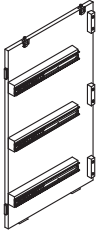
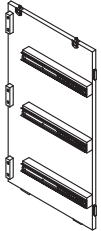
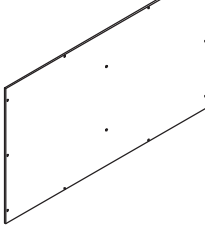
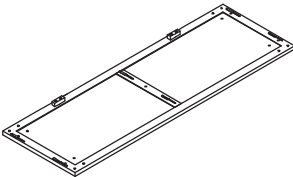
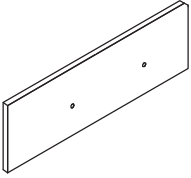
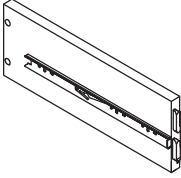
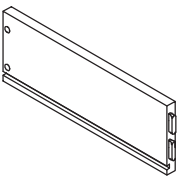
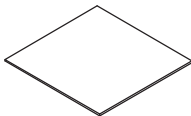
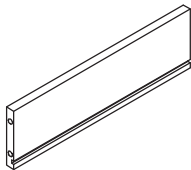
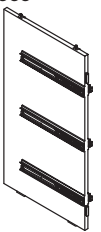
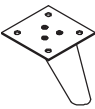

Email "warranty@mavenliving.com" to submit your warranty claim. Please keep your receipt so that we may process your warranty request.

HOW STATE LAW APPLIES

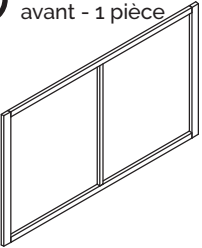
This warranty gives you specific legal rights, and you may also have other rights which vary from state to state.

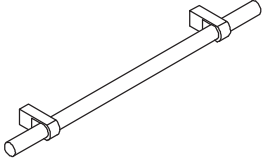
The foregoing warranty shall be exclusive and in lieu of any other warranty, express or implied, including warranties of merchantability and fitness for a particular purpose and all other warranties otherwise arising by operation of law, course of dealing, custom, trade, or otherwise. Neither the seller nor the manufacturer shall be liable for any injury, loss or damage, direct or consequential arising out of the use or inability to use this product.

COMMODE LAMINÉE À 6 TIROIRS - SÉRIE A

	<p>A Panneau supérieur - 1 pièce</p> 	<p>B Panneau latéral gauche - 1 pièce</p> 	<p>C Panneau latéral droit - 1 pièce</p> 	<p>D Panneau arrière - 1 pièce</p> 	<p>E Panneau inférieur - 1 pièce</p> 	
	<p>F Façade du tiroir - 6 pièces</p> 	<p>G Côté gauche du tiroir - 6 pièces</p> 	<p>H Côté droit du tiroir - 6 pièces</p> 	<p>I Panneau du bas du tiroir - 6 pièces</p> 	<p>J Arrière du tiroir - 6 pièces</p> 	
	<p>K Panneau central - 1 pièce</p> 	<p>L Pieds - 4 pièces</p> 	<p>M Pieds de soutien - 1 pièce</p> 	<p>N Cadre de face avant - 1 pièce</p> 	<p>1 Boulon Allen 25 mm - 36 pièces</p> 	
	<p>2 Poignée - 6 pièces</p> 	<p>3 Clé Allen - 1 pièce</p> 	<p>4 Vis de poignée 19mm - 12 pièces</p> 	<p>5 Boulon Allen 12 mm - 16 pièces</p> 		

OUTILS NÉCESSAIRES : Tournevis Phillips



Étape 1 : Fixez les pieds (L) et le pied de support (M) au panneau inférieur (E) à l'aide des boulons Allen (5) et de la clé Allen (3).

Remarque : Assurez-vous que les blocs de montage sont orientés vers le haut.

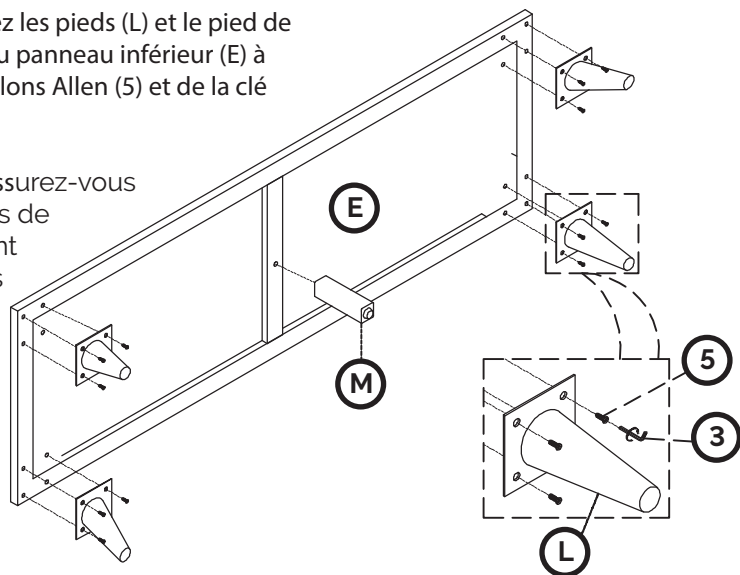

Étape 2 : Fixez le panneau latéral gauche (B), le panneau central (K) et le panneau latéral droit (C) au panneau inférieur (E) en plaçant les pièces en plastique dans les fentes et en faisant glisser les panneaux latéraux vers l'avant.

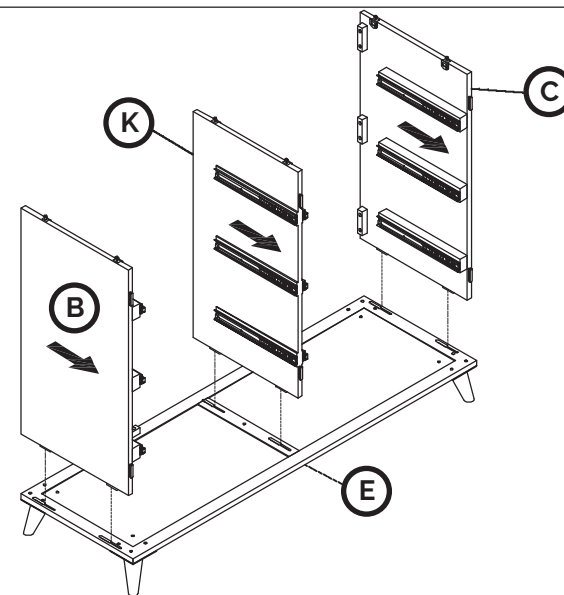

Étape 3 : Fixez le cadre de face avant (N) aux panneaux central et latéral (B, C, K) en plaçant les pièces en plastique dans les fentes et en faisant glisser le cadre frontal (N) vers le bas.

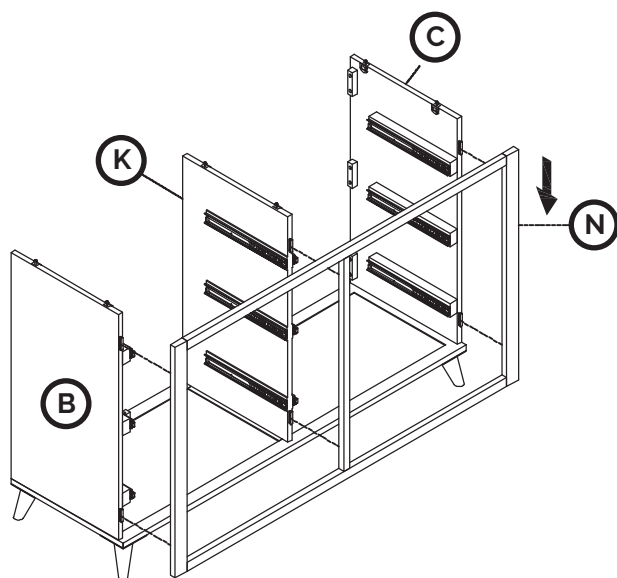

Étape 4 : Placez le panneau supérieur (A) sur les panneaux latéraux (B, C) et tournez les leviers des panneaux latéraux en position « fermée ».

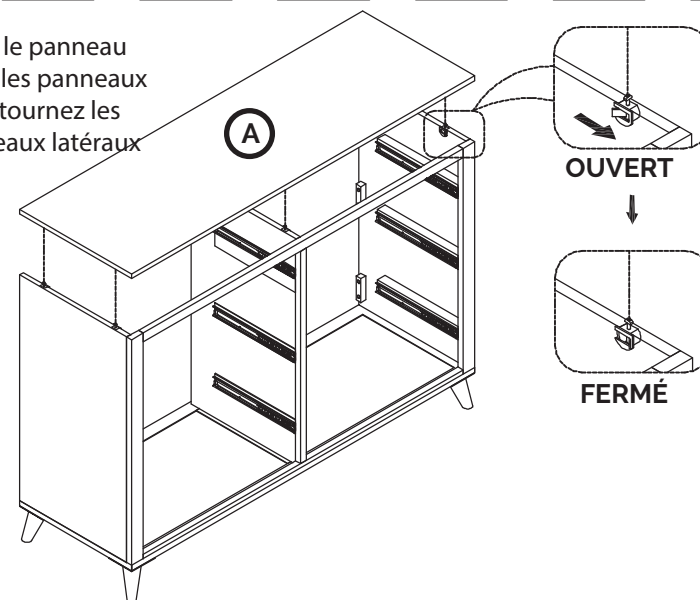

Étape 5 : Fixez le panneau arrière (D) aux blocs de montage à l'aide de boulons Allen (1) et de la clé Allen (3).

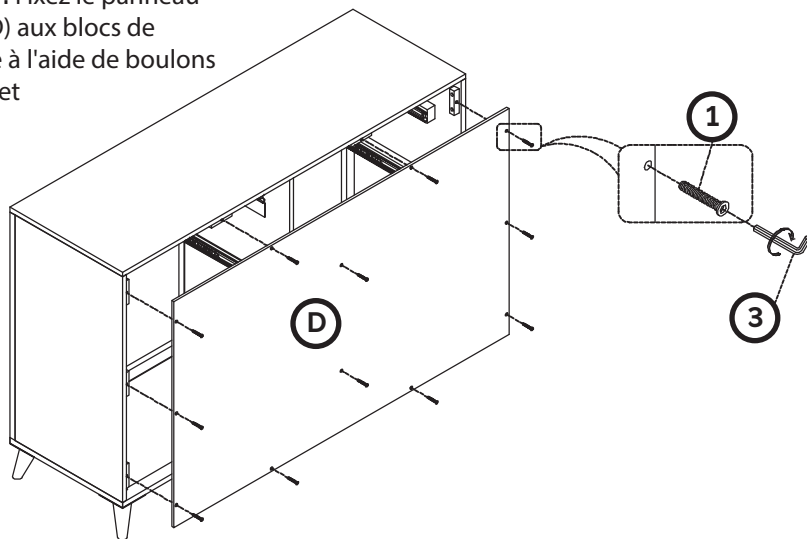

Étape 6 : Fixez le côté gauche du tiroir (G) et le côté droit du tiroir (H) à l'avant du tiroir (F) en plaçant les pièces en plastique dans les fentes et en faisant glisser l'avant du tiroir (F) vers le bas.

Remarque : Assurez-vous que les rails métalliques sont orientés vers l'extérieur et que la rainure du panneau inférieur est orientée vers le bas.

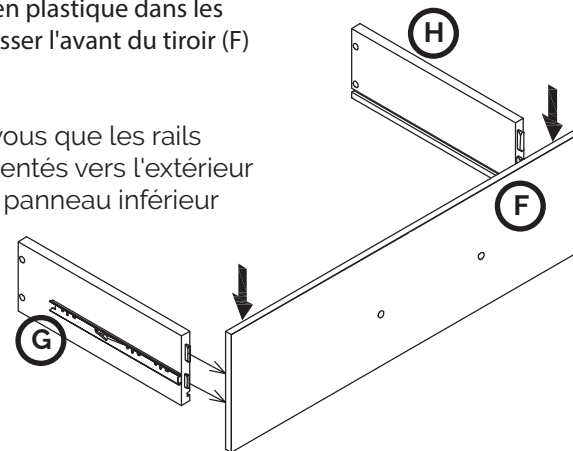

Étape 7 : Faites glisser le panneau inférieur du tiroir (I) en place.

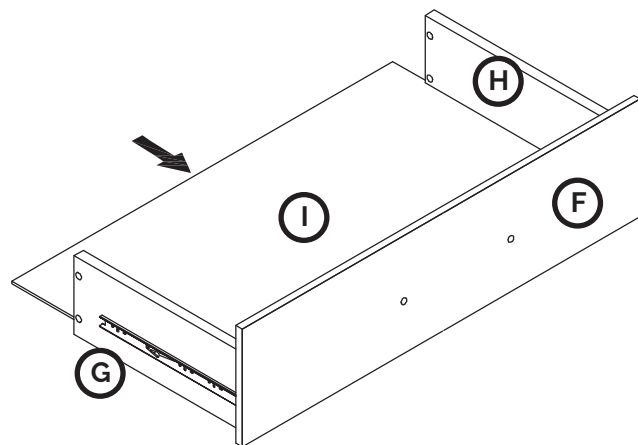

Étape 8 : Fixez le tiroir (J) aux côtés du tiroir (G, H) à l'aide de boulons Allen (1) et de la clé Allen (3).

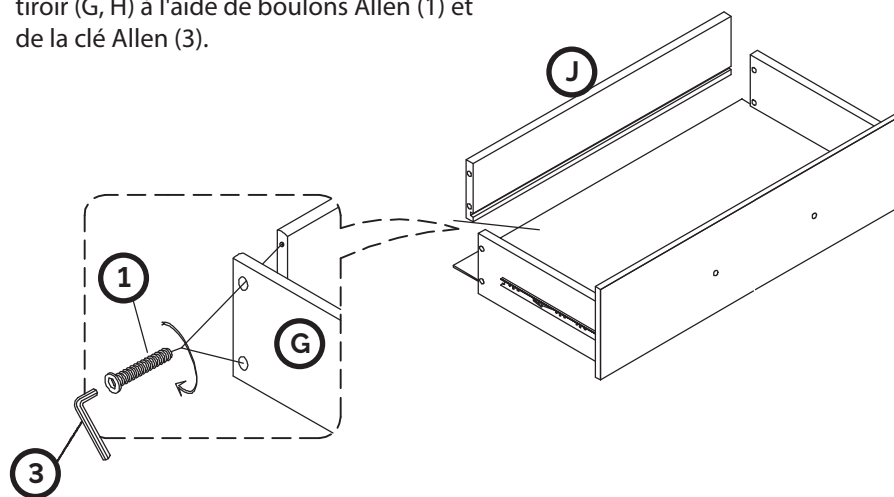

Étape 9 : Fixez une poignée (2) à l'avant du tiroir (F) à l'aide d'une vis (4) et d'un tournevis cruciforme.

Répétez les étapes 6 à 9 pour chaque tiroir

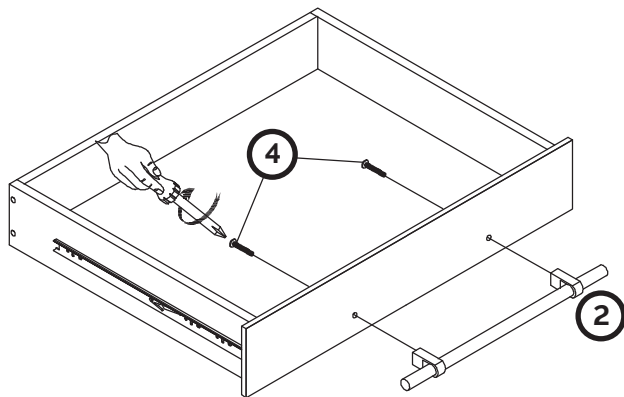

Étape 10 : Placez les tiroirs dans le cadre de la commode sur les rails métalliques et glissez lentement les tiroirs en place jusqu'à ce qu'ils soient complètement fermés.

Pour retirer les tiroirs, utilisez le levier de déverrouillage. Tirez le tiroir le plus loin possible et vous verrez un levier en plastique de chaque côté. Tirez un levier vers le haut et poussez l'autre vers le bas pour retirer le tiroir.

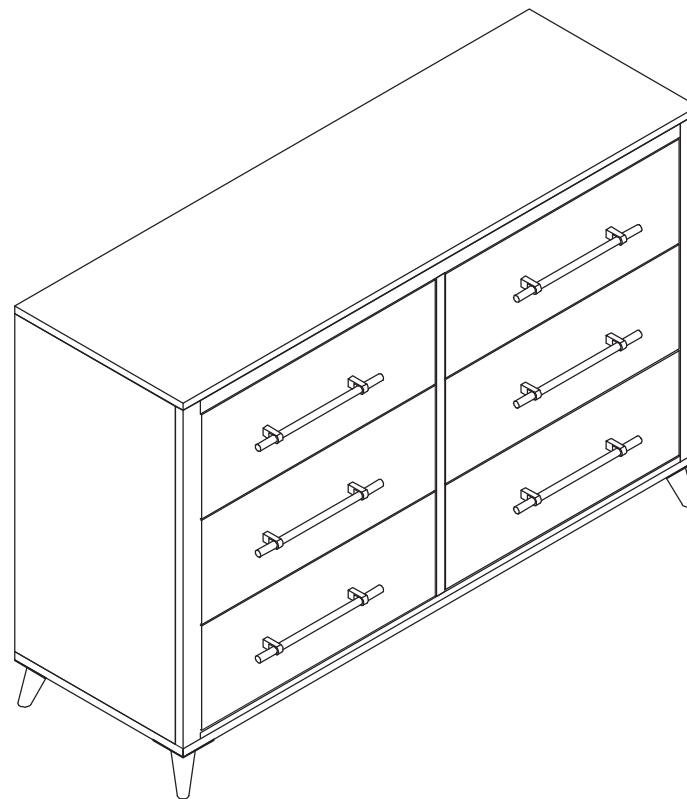
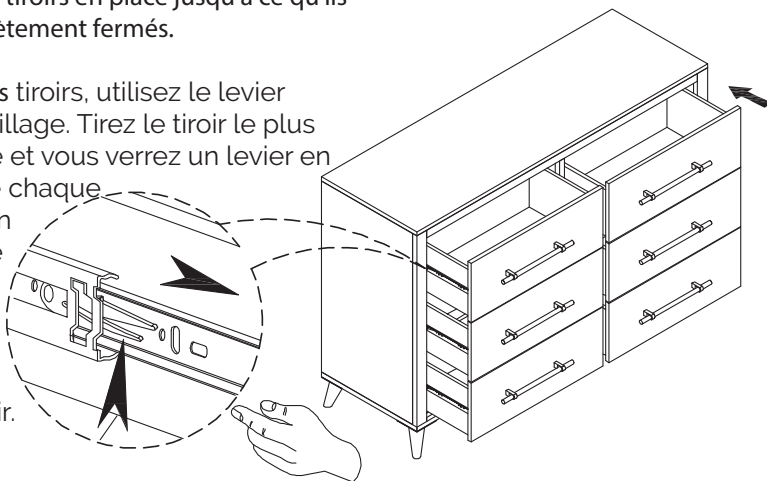

GARANTIE LIMITÉE DE 1 AN

CE QUI EST COUVERT PAR LA GARANTIE

Cette garantie couvre tout défaut de matériau ou de fabrication, sauf indication contraire ci-après.

COMBIEN DE TEMPS DURE LA GARANTIE?

Cette garantie est effective pendant une période de un (1) an à compter de la date d'achat.

CE QUI N'EST PAS COUVERT PAR LA GARANTIE

La garantie ne s'applique qu'à l'acheteur original et ne couvre pas : a) l'usure; (b) maintenance inadéquate, mauvaise utilisation ou modification; (c) réparation par des représentants non autorisés; (d) les dommages résultant du transit ou de la manutention; ou e) les frais de transport.

CE QUE NOUS FERONS

À notre seule discrétion, nous réparerons, remplacerons ou rembourserons le prix d'achat de tout produit qui s'avérera défectueux en raison d'un défaut de matériaux ou de fabrication.

COMMENT OBTENIR LE SERVICE DE GARANTIE







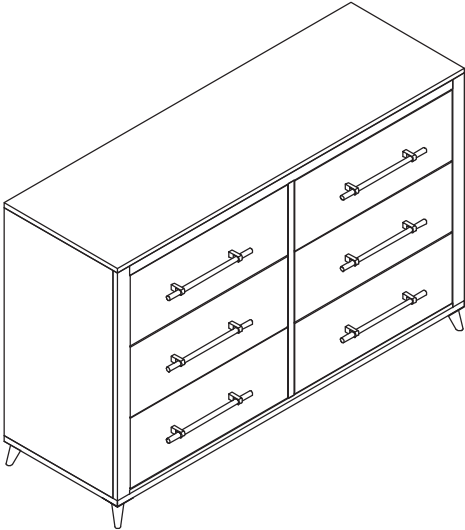
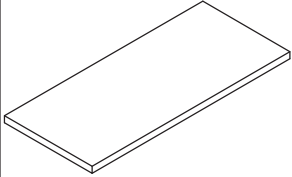
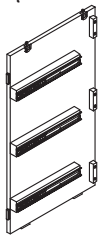
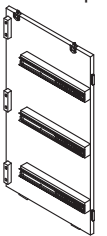
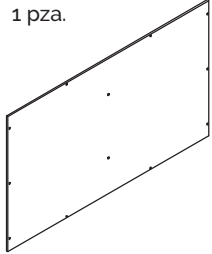
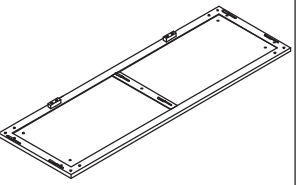
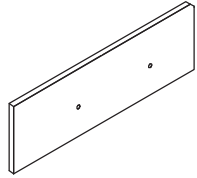
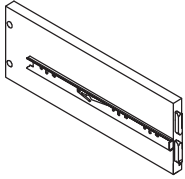
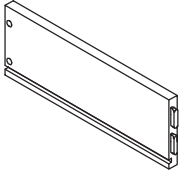
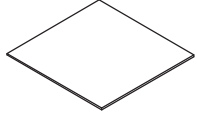
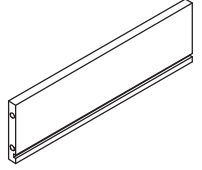
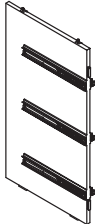
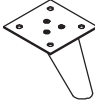

Envoyez un courriel à warranty@mavenliving.com pour soumettre votre demande de garantie. Veuillez conserver votre reçu d'origine afin que nous puissions traiter votre demande de garantie.

COMMENT S'APPLIQUE LA LOI DE L'ÉTAT

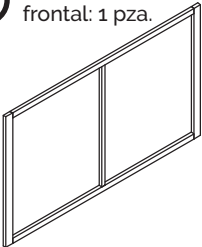
Cette garantie vous donne des droits juridiques spécifiques et vous pouvez également disposer d'autres droits qui varient d'un état/province à l'autre.

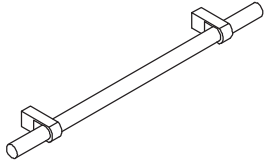
La présente garantie est exclusive et remplace toute autre garantie, expresse ou implicite, notamment les garanties de qualité marchande et d'adéquation à un usage particulier et toutes les autres garanties découlant autrement en vertu de la loi, du cours des affaires, personnalisé, commerce, ou autrement. Ni le vendeur ni le fabricant ne seront responsables des blessures, pertes ou dommages, directs ou indirects, résultant de l'utilisation ou de l'impossibilité d'utiliser ce produit.

CÓMODA DE 6 CAJONES LAMINADA: SERIE A

	<p>A Panel superior: 1 pza.</p> 	<p>B Panel lateral izquierdo: 1 pza.</p> 	<p>C Panel lateral derecho: 1 pza.</p> 	<p>D Panel trasero: 1 pza.</p> 	<p>E Panel inferior: 1 pza.</p> 	
	<p>F Parte delantera del cajón: 6 pzas.</p> 	<p>G Lado izquierdo del cajón: 6 pzas.</p> 	<p>H Lado derecho del cajón: 6 pzas.</p> 	<p>I Panel inferior del cajón: 6 pzas.</p> 	<p>J Parte trasera del cajón: 6 pzas.</p> 	
	<p>K Panel central: 1 pza.</p> 	<p>L Patas: 4 pzas.</p> 	<p>M Pata de soporte: 1 pza.</p> 	<p>N Marco de cara frontal: 1 pza.</p> 	<p>1 Tornillo Allen de 25 mm: 36 pzas.</p> 	
	<p>2 Agarradera: 6 pzas.</p> 	<p>3 Llave Allen: 1 pza.</p> 	<p>4 Tornillo de agarradera de 19 mm: 12 pzas.</p> 	<p>5 Tornillo Allen de 12 mm: 16 pzas.</p> 		

HERRAMIENTAS NECESARIAS: Desarmador Phillips



Paso 1: Adjunta las patas (L) y la pata de soporte (M) al panel inferior (E) con los tornillos Allen (5) y la llave Allen (3).

Nota: Asegúrate de que los bloques de montaje estén hacia arriba.

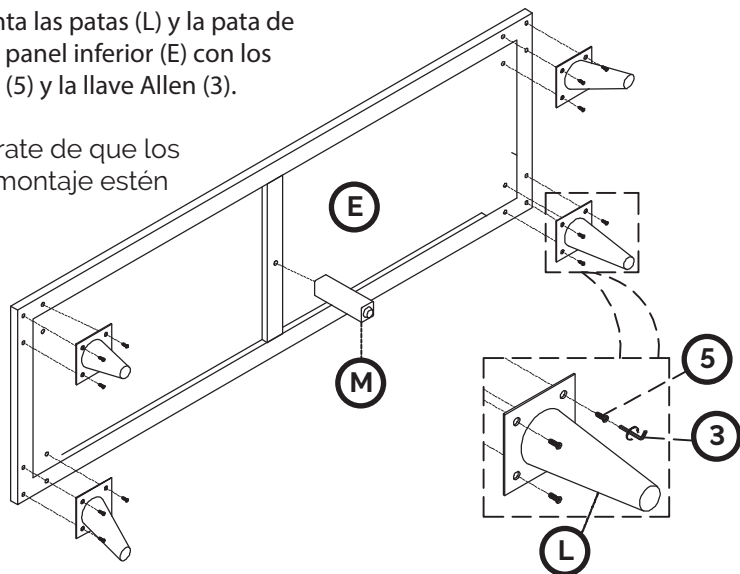

Paso 2: Adjunta el panel lateral izquierdo (B), el central (K) y el lateral derecho (C) en el panel inferior (E) colocando las piezas de plástico en las ranuras y deslizando los paneles laterales hacia el frente.

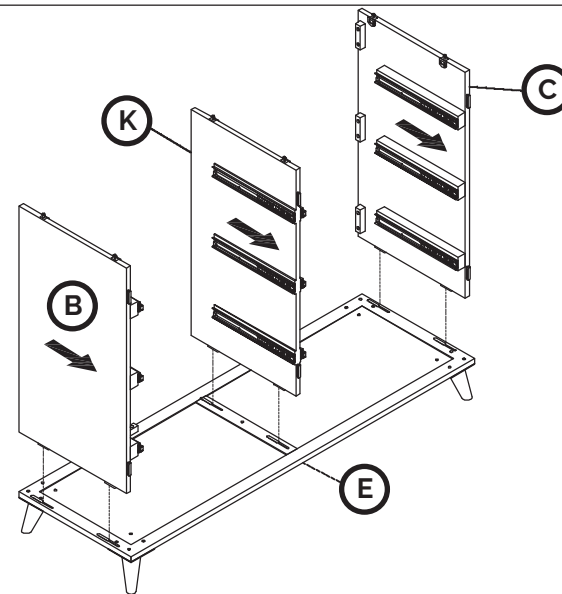

Paso 3: Asegura el marco de cara frontal (N) a los paneles central y lateral (B, C, K) colocando las piezas de plástico en las ranuras y deslizando el marco de cara frontal (N) hacia abajo.

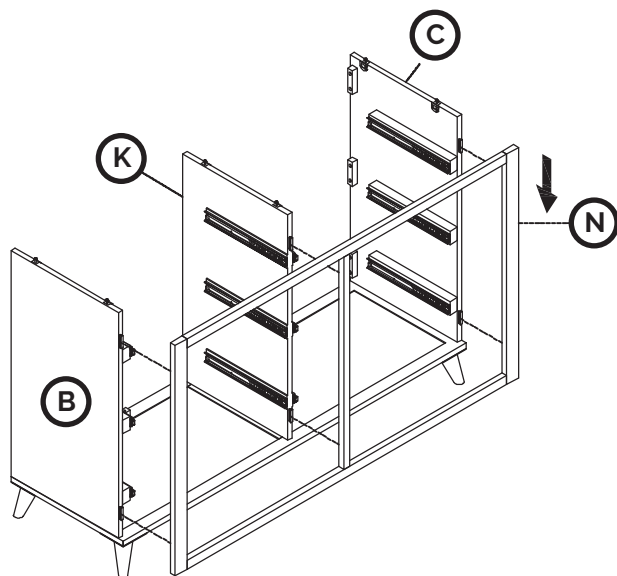

Paso 4: Coloca el panel superior (A) sobre los paneles laterales (B, C) y voltea las palancas de los paneles laterales a la posición "cerrada".

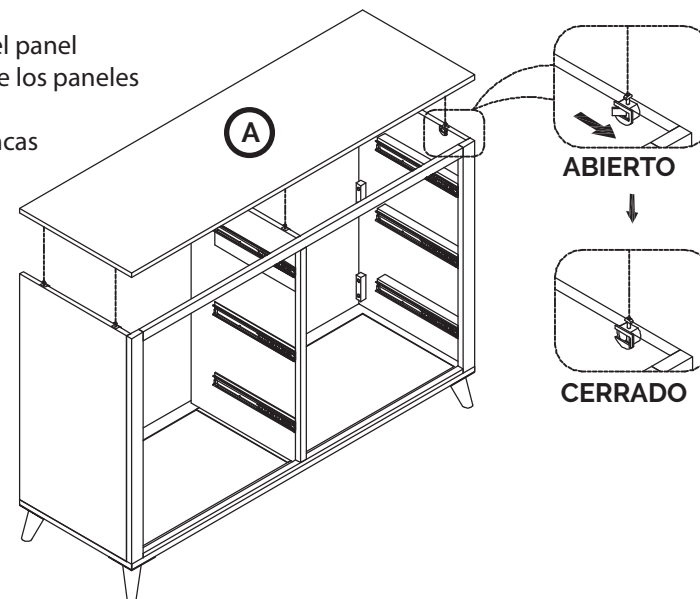

Paso 5: Asegura el panel trasero (D) a los bloques de montaje con tornillos Allen (1) y la llave Allen (3).

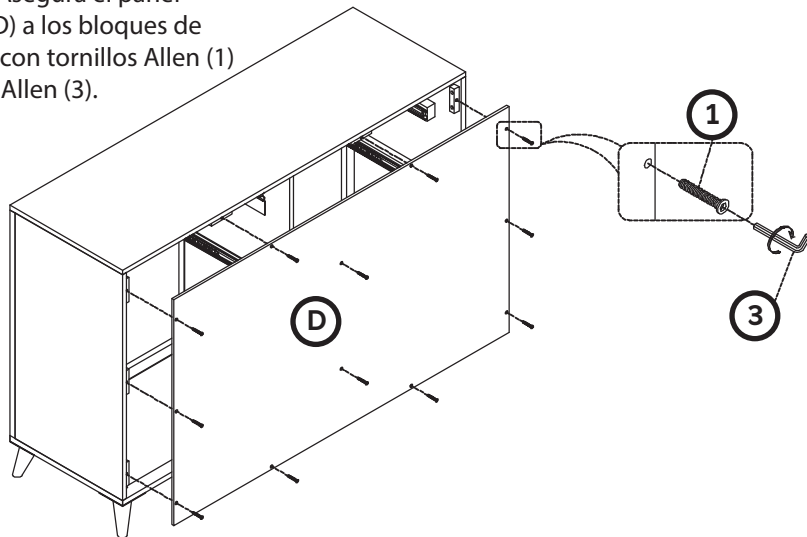

Paso 6: Fija el lado izquierdo del cajón (G) y el lado derecho del cajón (H) a la parte delantera del cajón (F) colocando las piezas de plástico en las ranuras y deslizando la parte delantera del cajón (F) hacia abajo.

Nota: Asegúrate de que los rieles de metal estén orientados hacia afuera y la ranura del panel inferior esté hacia el fondo.

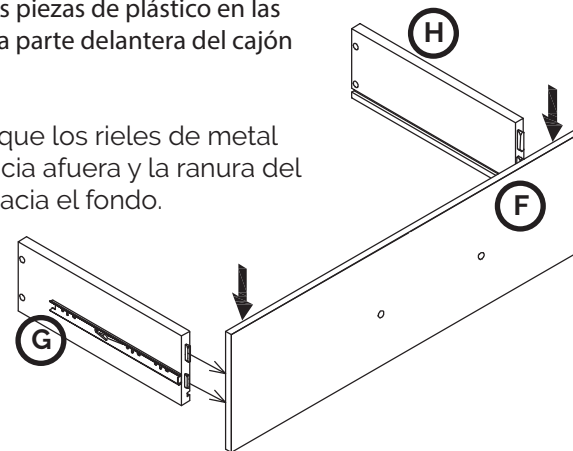

Paso 7: Desliza el panel inferior del cajón (I) en su lugar.

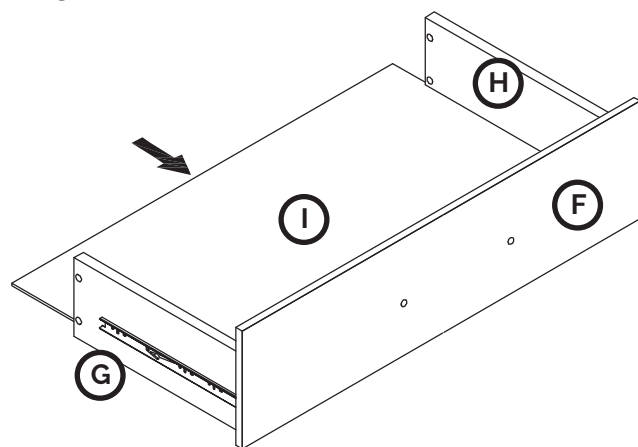

Paso 8: Adjunta la parte trasera del cajón (J) a los laterales del mismo (G, H) con los tornillos Allen (1) y la llave Allen (3).

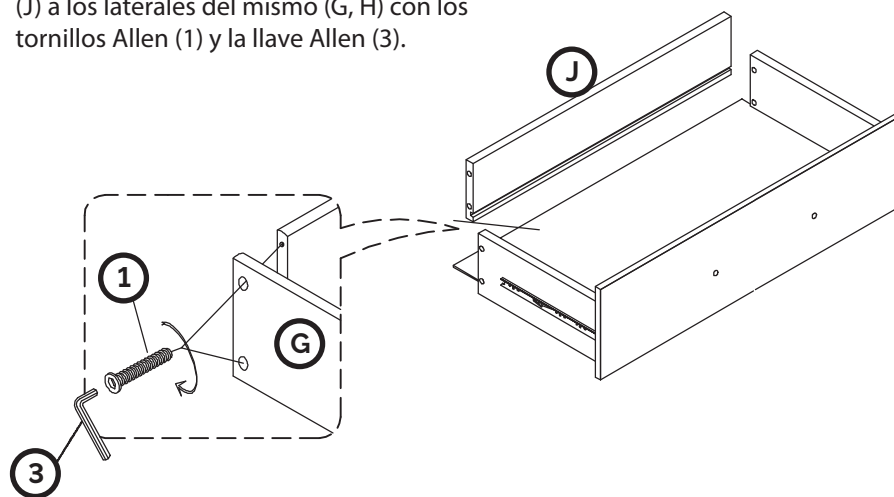

Paso 9: Adjunta la agarradera (2) a la parte delantera del cajón (F) con un tornillo (4) y destornillador Phillips.

Repite los pasos 6-9 para cada cajón.

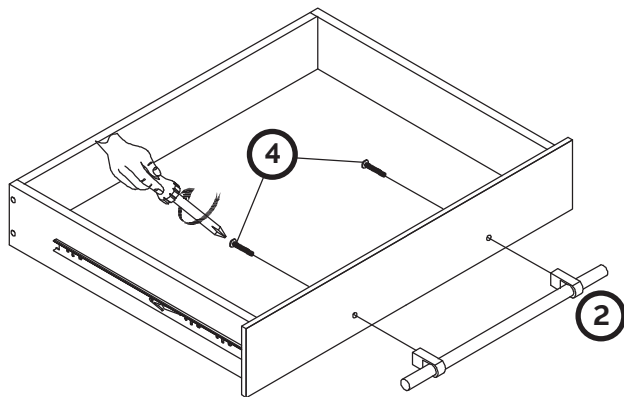

Paso 10: Coloca los cajones en el marco de la cómoda sobre los rieles metálicos y coloca los cajones en su lugar cuidadosamente hasta que los cierres por completo.

Para quitar los cajones, usa la palanca de liberación. Tira del cajón lo más lejos posible para ver una palanca de plástico a cada lado. Tira de la palanca hacia arriba y empuja la otra hacia abajo para sacar el cajón.

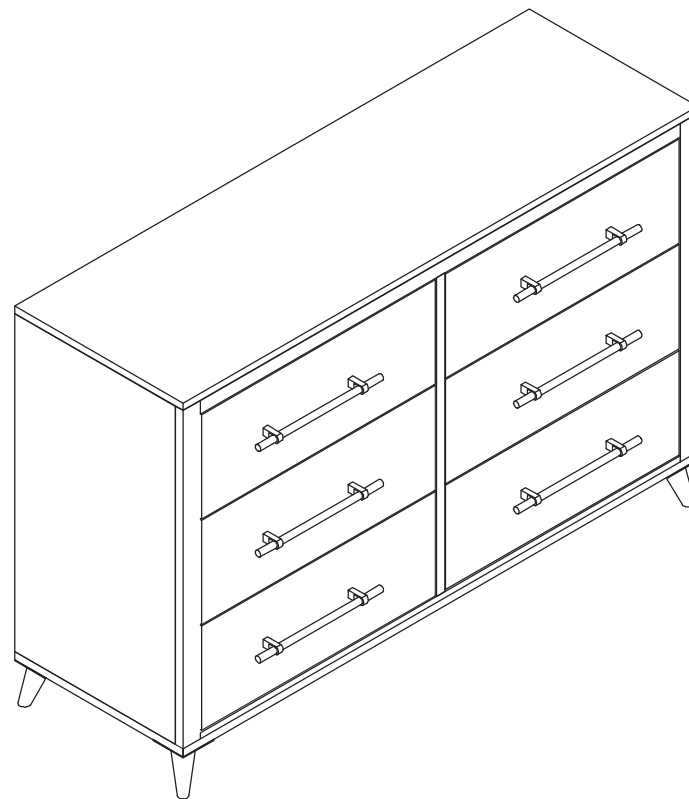
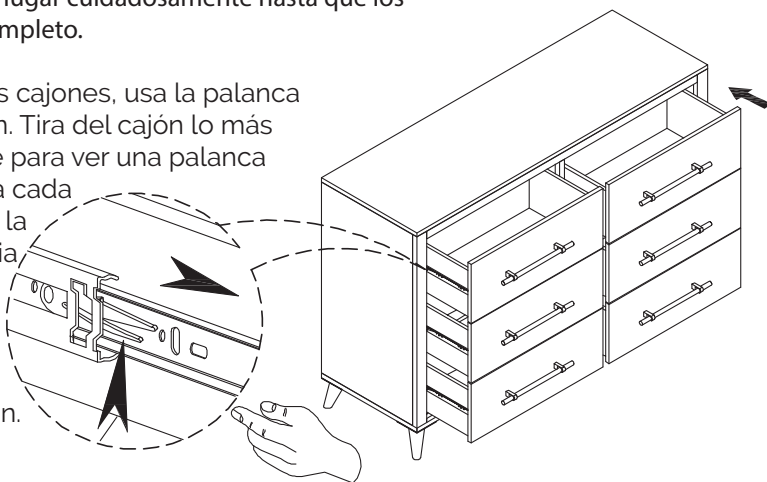

GARANTÍA LIMITADA DE 1 AÑO

LO QUE CUBRE

La garantía cubre cualquier defecto de fabricación o de material, con las excepciones que se mencionan más adelante.

POR CUÁNTO TIEMPO ES VÁLIDA LA COBERTURA

Esta garantía tiene una duración de un (1) año a partir de la fecha de compra.

LO QUE NO CUBRE

La garantía solo es válida para el comprador inicial y no cubre: (a) el desgaste por uso; (b) el mantenimiento incorrecto, el mal uso o la alteración del producto; (c) la reparación por parte de representantes no autorizados; (d) el daño generado por el traslado o el manejo del producto; o (e) los costos de transporte.

La garantía anterior será exclusiva y sustituirá a cualquier otra garantía, expresa o implícita, incluidas las garantías de comerciabilidad e idoneidad para un fin determinado y todas las demás garantías que surjan de otro modo por la aplicación de la ley, el curso de las negociaciones, la costumbre, el comercio o de cualquier tipo. Ni el vendedor ni el fabricante asumirán responsabilidad alguna por cualquier lesión, pérdida o daño, sea directo o consecuente, que surja como resultado de utilizar o no poder utilizar este producto.

LO QUE HAREMOS

A nuestra entera discreción, repararemos, reemplazaremos o reembolsaremos cualquier producto que tenga defectos de fábrica o de material comprobables.

COMO OBTENER EL SERVICIO

Envía un correo electrónico a "warranty@mavenliving.com" para presentar tu reclamación de garantía. Guarde su recibo para que podamos procesar su solicitud de garantía.

CÓMO APLICAN LAS LEYES ESTATALES

Esta garantía te da derechos legales específicos y también puedes tener otros derechos que varían de un estado a otro.