



# Vertical Electric Analog Smoker

MODEL #DGU505BAE / DGU505BAE-D

Français p. 28

Español p. 56

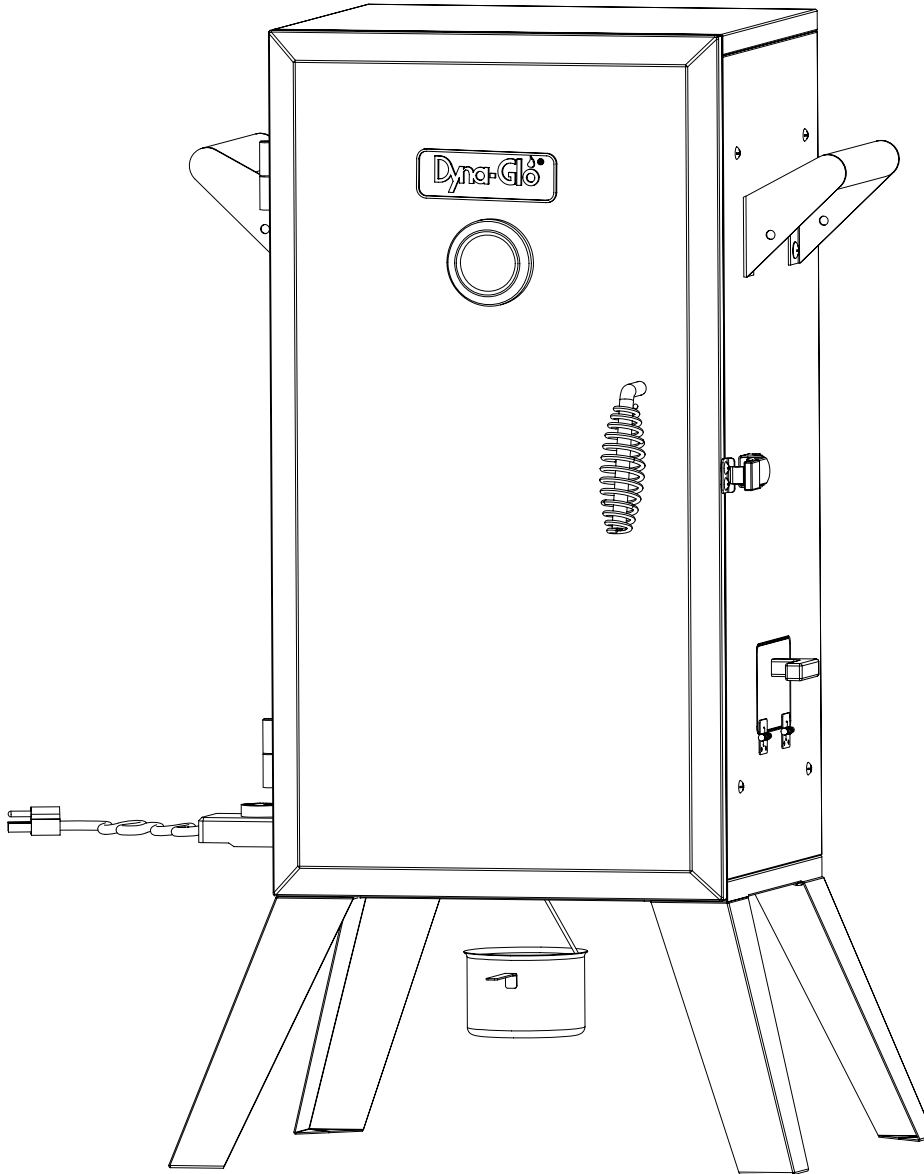

**FOR OUTDOOR  
USE ONLY**  
Use only with Class A GFI  
(Ground Fault Interrupter)

**ATTACH YOUR RECEIPT HERE**

Serial Number \_\_\_\_\_ Purchase Date \_\_\_\_\_



**Questions, problems, missing parts?** Before returning to your retailer, call our customer service department at 1-877-447-4768, 8:00 a.m. – 4:30 p.m. CST, Monday – Friday or e-mail us at [customerservice@ghpgroupinc.com](mailto:customerservice@ghpgroupinc.com).



**NO NEED TO RETURN TO THE STORE**

Questions With The Assembly?  
Require Parts Information?  
Product Under Manufacturers Warranty?

Call Toll Free : 1-877-447-4768  
8:00 a.m. – 4:30 p.m. CST, Monday – Friday

**Retain This Owner's Manual And Proof Of Purchase For Future Reference**

**To help us help you**

Fill in the information below:

--	--	--	--

Date of Purchase

Place of Purchase

Model Number

Product Serial No.

MODEL NUMBER AND PRODUCT SERIAL NUMBER CAN BE FOUND ON  
THE RATING LABEL OF YOUR GRILL.

## TABLE OF CONTENTS

---

Safety Information .....	3
Package Contents .....	8
Hardware Contents .....	9
Preparation Before Assembly .....	9
Assembly Instructions .....	10
Operating Instructions .....	17
Tips On Smoking .....	21
Care and Maintenance .....	23
Troubleshooting .....	24
Replacement Parts List .....	26
Warranty .....	27

Assembler/Installer: This instruction manual contains important information necessary for the proper assembly and safe use of this appliance. Read and follow all warnings and instructions before assembling and using this appliance. **Leave these instructions with the consumer.**

**Consumer/User: Follow all warnings and instructions when using this appliance.**

## SAVE THESE INSTRUCTIONS

### SAFETY INFORMATION

---

Please read and understand this entire manual before attempting to assemble, operate or install the product. If you have any questions regarding the product, call our customer service department at 1-877-447-4768, 8:00 a.m.- 4:30 p.m. CST, Monday - Friday.

### CAUTION

- When using electrical appliances, basic precautions should always be followed to reduce the risk of fire, electrical shock, and injury to persons.

### DANGER

- Failure to follow these instructions could result in fire or burn hazard which could cause property damage, personal injury or death.

## IMPORTANT SAFEGUARDS

READ ALL INSTRUCTIONS, PRIOR TO USING THIS SMOKER

- **DO NOT** use this product for anything other than its intended purpose. It is **NOT** intended for commercial use. It is **NOT** intended to be installed or used in or on a recreational vehicle and/or boat.
- **DO NOT** operate this smoker with a damaged cord or plug or after the smoker malfunctions, has been dropped, or is damaged in any manner. If the supply cord is damaged, it must be replaced by a special cord or assembly available from the manufacturer or its service agent.
- **DO NOT** use smoker within 10 feet (3 m) of a swimming pool, puddle, pond or other body of water.
- Keep smoker and electric controller dry and out of rain at all times.
- A minimum clearance of 36 in. (92 cm) to combustible material is required on the front, sides and back. It is very important to always maintain proper clearances to combustibles.
- When using flavoring wood, add a sufficient amount at the start of the cooking process, in order to avoid re-adding wood during the cooking process. Adding wood while operating may splash hot water and cause serious injury.
- Check the water level at least every 2 hours. A sizzling sound may indicate a low water level. Follow instructions in this manual for adding water while operating (see Page 17).
- **DO NOT** use the appliance during an electrical storm.
- Connect to properly grounded outlets only. The appliance is to be connected to a socket-outlet having an earthing contact.
- Use only with a Class A GFI (Ground Fault Interrupter) protected circuit.
- The appliance should be supplied through a residual current device (RCD) having a rated residual operating current not exceeding 30 mA.
- Arrange the power cord away from traffic areas to ensure that it is not tripped over.
- To disconnect the smoker, turn the smoker off by turning the control dial to O (OFF), and removing the plug from the outlet.
- **DO NOT** obstruct the flow of ventilated air for the appliance.
- **DO NOT** use metal foil on the cooking grates. Doing so may result in damage to the smoker.
- **DO NOT** use this appliance as a heater.
- **DO NOT** use charcoal or similar combustible fuels with this appliance. This appliance is not designed for use with charcoal and a fire will result if charcoal is used during operation. The fire will create an unsafe condition and damage the smoker.
- Use caution when opening the door of the smoker while in operation. Keep hands, face and body safe from hot steam or flare-ups. **DO NOT** inhale smoke.
- If you must dispose of ashes in less time than it takes for the ashes to completely cool down, then remove the ashes from the appliance using insulated oven mitts or gloves and completely soak the ashes with water before disposing of them in a noncombustible container.
- **DO NOT** wear loose clothing while operating the smoker. Tie back long hair while operating the smoker.
- **ALWAYS** wear shoes that fully cover your feet while operating the smoker.

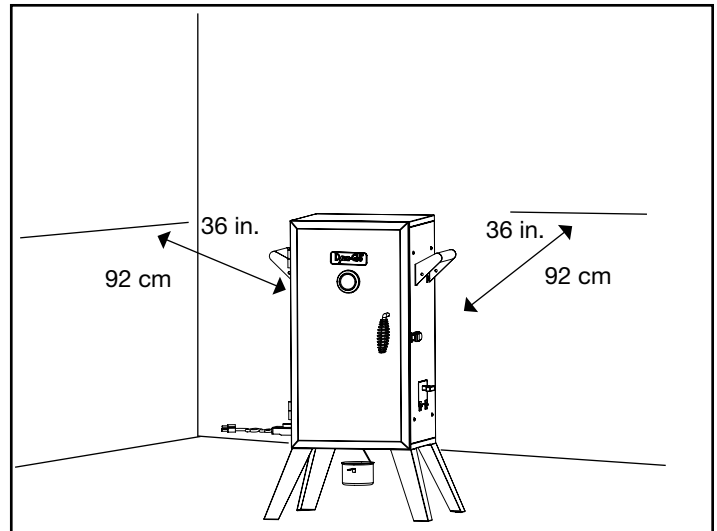

## SAFETY INFORMATION

---

- **DO NOT** touch hot surfaces. Use handles or knobs.
- To protect against electrical shock do not immerse cord, plugs, or thermostat control assembly in water or other liquid.
- Close supervision is necessary when any appliance is used by or near children. This appliance is not intended for use by persons (including children) with reduced physical, sensory or mental capabilities, or lack of experience and knowledge, unless they have been given supervision or instruction concerning use of the appliance by a person responsible for their safety.
- Unplug from outlet when not in use and before cleaning. Allow to cool before putting on or taking off parts.
- **DO NOT** operate any appliance with a damaged cord or plug or after the appliance malfunctions or has been damaged in any manner. Return appliance to the nearest authorized service facility for examination, repair, or adjustment.
- The use of accessory attachments not recommended by the appliance manufacturer may cause injuries.
- **DO NOT** use indoors.
- **DO NOT** let cord hang over edge of table or counter, or touch hot surfaces.
- Do not place on or near a hot gas or electric burner, or in a heated oven.
- Extreme caution must be used when moving an appliance containing hot oil or other hot liquids.
- Always attach plug to appliance first, then plug cord into the wall outlet. To disconnect, turn the control dial to O (OFF), then remove plug from wall outlet.
- **DO NOT** use appliance for any reason other than intended use.
- Use extreme caution when removing trays or disposing of hot grease.
- **DO NOT** clean with metal scouring pads. Pieces can break off the pad and touch electrical parts, creating a risk of electric shock.
- Fuel, such as charcoal briquettes, is not to be used with appliance.
- Use only on properly grounded outlet.
- Be sure that handles are assembled and fastened properly. See instructions regarding handles on Page 11.
- **SAVE THESE INSTRUCTIONS.**

### **WARNING**

- **DO NOT** use 16 or 18 gauge extension cords. Damage to household wiring and/or fire could result.

### **THE USE OF AN EXTENSION CORD IS NOT RECOMMENDED.**

READ ALL INSTRUCTIONS, PRIOR TO USING AN EXTENSION CORD WITH THIS SMOKER

- Use only **OUTDOOR** type with 3 prong grounding plug, rated for 15 amperes or more, approved by UL, marked with a W-A and a tag stating “Suitable for Use with Outdoor Appliance”.
- Use the shortest length extension cord required. Do not connect 2 or more extension cords together.
- Do not let cord hang over edge of table top or other items where it can be pulled by children or tripped over.

## SAFETY INFORMATION

---

### Ground Fault Interrupter

- Since 1971 the National Electric Code (NEC) has required Ground Fault Interrupter devices on all outdoor circuits.
- If your residence was built before 1971, check with a qualified electrician to determine if a Ground Fault Interrupter protector exists.
- Do not use this appliance if the circuit does not have Class A GFI protection.
- Do not plug this appliance into an indoor circuit.

### GENERAL SAFETY

#### READ ALL INSTRUCTIONS PRIOR TO USING THIS SMOKER

- This appliance is for outdoor use only in well-ventilated areas. **DO NOT** operate it under a roof, in a building, garage or any other enclosed area, or under overhead construction.
- Before each use check that no dead leaves or debris are under the appliance.
- Keep a fire extinguisher near this product at all times.
- Always unplug the smoker when not in use.
- Allow the smoker and its components to cool completely before conducting any routine cleaning or maintenance.
- **DO NOT** use water or other liquid spray to clean the smoker without first unplugging the unit.
- Allow the smoker to cool to 115°F (45°C) before moving or storing. Use caution when lifting and moving the appliance to avoid back strain or back injury.
- **DO NOT** move the appliance while it is in use.
- When not in use, the smoker should be kept out of the elements or protected with a cover. Allow the smoker to completely cool before placing the cover. Store this appliance in a dry, protected location when possible.
- Use of accessory attachments not recommended by the appliance manufacturer may lead to injury or property damage.

**! WARNING !**

To Avoid Serious Injury:

- While cooking, the smoker must be on a level, stable, noncombustible surface in an area clear of combustible material, including long or dry grass.
- The use of alcohol, prescription or nonprescription drugs may impair the user's ability to properly assemble and safely operate this appliance.
- **DO NOT** move the appliance while it is in use.
- **DO NOT** store and use this appliance near gasoline or other combustible liquids or where other combustible vapors may be present.
- The smoker should only be used in well ventilated areas.
- **DO NOT** use this appliance as a heater.
- **DO NOT** leave the appliance unattended while in use. Keep children and pets away from the appliance at all times.
- This appliance will be hot during and after use. Use insulated oven mitts or gloves for protection from hot surfaces or splatter from cooking liquids.

**CALIFORNIA PROPOSITION 65**

**! WARNING**

This product and the fuels used to operate this product (charcoal or wood), and the products of combustion of such fuels, can expose you to chemicals including carbon black, which is known to the State of California to cause cancer, and carbon monoxide, which is known to the State of California to cause birth defects or other reproductive harm.

For more information go to [www.p65Warnings.ca.gov](http://www.p65Warnings.ca.gov)

**! DANGER !**

**In case of fire, unplug smoker from outlet and allow fire to burn out. Do not use water to put out a fire in this or another electrical appliance.**

**To avoid electrical shock, disconnect electric cord before cleaning smoker. Never immerse electric controller or heating element in any liquid.**

**To avoid the possibility of burns make sure the smoker is completely cooled before removing and/or cleaning electric controller and heating element.**

**DO NOT use steel wool or wire brushes to clean the inside of the appliance. Pieces can break off and touch electrical parts creating a risk of electric shock.**

## OPERATING INSTRUCTIONS

---

### READ ALL INSTRUCTIONS PRIOR TO USING THE SMOKER FOR THE FIRST TIME

#### Before Initial Use:

Remove all packaging, hang tags, plastic straps, and sales stickers if present. Do not use sharp tools.

Wash cooking grates with warm, soapy water, rinse and allow to completely dry before placing them back into the smoker.

Prior to initial use, it is important to “season” your smoker. Seasoning helps eliminate potential factory residue that occurs during production and also enhances flavoring, durability and overall performance. Refer to Page 19 for instructions on how to season the smoker.

#### Before Each Use:

### READ ALL INSTRUCTIONS PRIOR TO USING THE SMOKER

- The smoker must be on a level, stable, noncombustible surface in an area clear of combustible material, including long or dry grass.
- Avoid moving the smoker over bumpy or uneven surfaces. Damage to the smoker may occur as a result.
- To prevent household circuit breakers from tripping, keep electric smoker controls and cord connections dry and do not use other electrical products on the same circuit.
- Make sure the grease tray, wood chip box, and water bowl are clean and empty and placed back into the smoker according to the instructions.
- Lightly coat each cooking grate with vegetable oil or vegetable oil spray to prevent foods from sticking to the grates during cooking.
- **DO NOT** cover the cooking grates with metal foil.

## ⚠ WARNING ⚠

**Failure to follow all manufacturer’s instructions could result in serious personal injury and/or property damage.**

**Use care when operating your smoker.**

**To avoid possible flare-ups or grease fires, clean and empty the water bowl and grease pan before use.**

**Read and follow all the information and safeguards in this product guide before attempting to assemble or operating this smoker.**

## ⚠ CAUTION ⚠

- **Do not use sharp or pointed tools to clean smoker.**
- **Do not use abrasive oven cleaners, steel wool or metal brushes to clean porcelain grates or smoker body. They will damage the finish.**
- **Replace damaged part(s) only with Dyna-Glo certified replacement parts. Do not attempt to repair damaged parts.**



## OPERATING INSTRUCTIONS

---

### Safety Guidelines

- Refer to the “Troubleshooting Section” on Pages 24 and 25 for operational problems.
- **DO NOT** open the smoker door while operating, unless it is necessary. Opening the door will allow heat to escape and prolong the cooking time.
- **DO NOT USE CHARCOAL.** This appliance is not designed for use with charcoal and a fire will result if charcoal is used during operation. The fire will create an unsafe condition and damage the smoker.
- **Wood Chips** must be used to create the smoke and flavor.
- In order to maintain optimal performance, cleaning the smoker after each use is highly recommended. Wait until the smoker has completely cooled before cleaning. Refer to the Care and Maintenance section on Page 23.

### Control Dial Operating Instructions

- The probe of the temperature control dial must be properly inserted into the external housing of the heating element and the dial should be set to the O (OFF) position before plugging the cord into an electrical (GFI) outlet. Refer to assembly instructions on Page 14 for inserting the thermostat control.

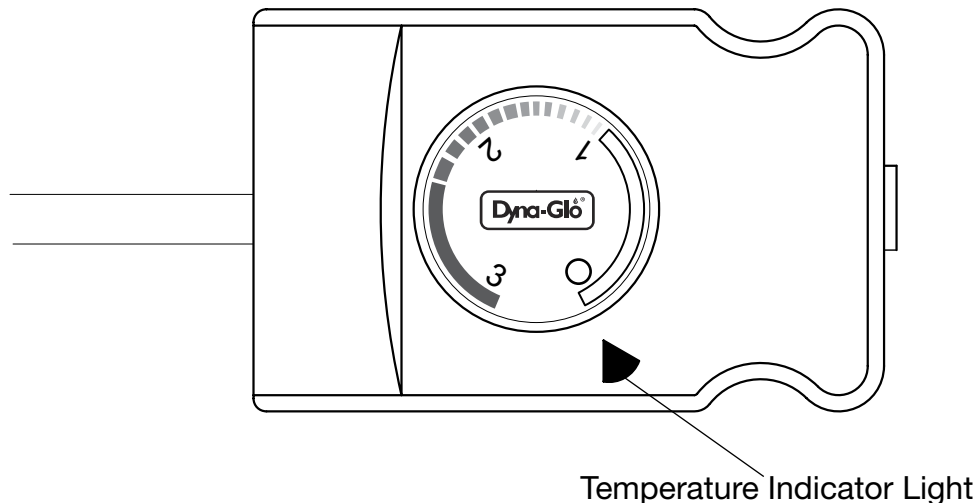

O - Off

1 - Low Temperature Setting

2 - Medium Temperature Setting

3 - High Temperature Setting

**NOTE:** Always leave the water bowl in place while operating the smoker. If additional water is needed during the cooking process, carefully pour water into the drip pan opening. **DO NOT** remove the water bowl to add water. Avoid splashing water onto the heating element. Serious damage to the heating element could result, along with flare-ups and electrical failure.

## OPERATING INSTRUCTIONS

---

### Seasoning the Smoker (Before Initial Use)

To season your smoker, follow these steps WITHOUT the use of food:

1. Place desired flavoring woods in wood chip box and fill to  $\frac{3}{4}$  full. DO NOT put water in the water bowl.
2. With the smoker door closed, turn the control dial to 3 (High) and maintain this burner setting for 2 hours.
3. Once seasoning is complete, your smoker's interior will have a durable, seasoned coating.
4. Allow the smoker completely cool, before cleaning out the wood chip box.

## ⚠ CAUTION ⚠

The smoker becomes HOT during use. Use heat resistant gloves while accessing the inside of the smoker.

### Cooking with the Smoker:

Turn the control dial clockwise  to set the desired temperature. The dial can be turned to any position between 1 (Low) and 3 (High). Turn the dial up (to increase the temperature) or down (to decrease the temperature), as needed, to fine-tune the desired temperature.

NOTE: The burner will not turn on until the dial is set to "1" (Low). The indicator light, near the control dial, will turn on and remain on until the smoker temperature has reached the desired setting.

Once the desired temperature is reached, the indicator light will turn off. The thermostat will continue regulating the desired temperature by automatically cycling the burner on and off during use. The internal temperature may fluctuate plus or minus 10-15°F (5-8°C) as the appliance cycles to maintain correct cooking temperature setting. Refer to Page 22 for more information on cooking temperatures.

### Using the Wood Chip Box:

The wood chip box is designed to provide a sustainable amount of smoke and flavor during the cooking process. Fill the box at least  $\frac{1}{2}$  to  $\frac{3}{4}$  full with desired wood chips or wood pellets. Anything more or less than this amount may not create the appropriate amount of smoke for adding flavor. Refer to Page 21 for the types of wood chips that are recommended for various foods. To add more wood chips or pellets during the cooking process, simply open the side access door and place a small handful of chips or pellets on the loader. Closing the door will allow the chips or pellets to fall into the wood chip box. Do not use wood chunks or charcoal. NOTE: The use of wood chips or wood pellets is not required during the cooking process.

**NOTE:** Always operate the smoker with the wood chip box in place – regardless of whether or not wood chips are used.

### Using the Water Bowl:

The use of water in the bowl is not required, but the water bowl MUST be in place during operation. To use the bowl, fill with NO MORE THAN 24 ounces (710ml) of warm water, before turning on the smoker. Cold water may prolong the cooking process. Do not overfill the water bowl. Doing so may cause the water to splash inside the smoker. **IMPORTANT:** Always cook with both the water bowl and wood chip box in place, regardless of whether or not they are filled.

### ⚠ CAUTION ⚠

- **Do not use sharp or pointed tools to clean smoker.**
- **Do not use abrasive oven cleaners, steel wool or metal brushes to clean porcelain grates or smoker body. They will damage the finish.**
- **Replace damaged part(s) only with Dyna-Glo certified replacement parts. Do not attempt to repair damaged parts.**

- In order to maintain optimal performance, cleaning the smoker after each use is highly recommended.
- Wait until the smoker has completely cooled before cleaning.
- Plastic or bristle brushes may be used for cleaning stubborn stains.
- **DO NOT** use steel wool or wire brushes. Pieces can break off and touch electrical parts creating a risk of electric shock.
- Clean the controller casing and heating element by wiping with a damp cloth. Use a mild detergent.
- Completely dry the controller casing and heating element before use. Failure to do so, may cause damage to the controller and prevent the smoker from working properly.
- Clean the cooking grates with warm soapy water or with a water & baking soda solution. Non- abrasive scouring powder can be used for stubborn stains.
- Clean the grease tray and water bowl with a damp cloth and warm soapy water. Allow the liquids inside the water bowl and grease tray to cool completely before cleaning.
- Avoid cleaning the cooking surfaces, while the smoker is still hot.
- Follow all warnings and safety precautions before removing meat from smoker or preparing the unit for storage. Please see Page 3 for important warnings and safeguards.

## TIPS ON SMOKING

---

Pairing wood chips with a specific type of food will depend on the preferences of the user. This page can be used as a general guideline for acquiring the ideal flavor.

- Hardwoods such as hickory, pecan, apple, cherry or mesquite typically burn slower and produce more smoke over longer periods of time.
- To prolong the burn cycle for wood chips, pre-soak them in a separate bowl of water for at least 30 minutes, and/or wrap the chips in perforated aluminum foil.
- Most smoke flavoring occurs within the first hour of cooking. **Adding wood chips after the first hour is typically not necessary unless extra smoke flavoring is desired.**

Here's a list of the most popular smoking woods and a little information about each.

Type of Wood	Suggested Food	Comments
Apple	All meats	Mild and sweet flavor with a slight hint of fruity flavor. Each species of apple wood should offer a slightly different flavor. Apple smoke produces an attractive browning effect.
Almond	All meats	Produces a sweer smoke with a natural nutty flavor.
Ash	Fish and red meat	Very light flavor.
Citrus	Pork and chicken	Lemon and orange wood produce a light but fruity flavor.
Cherry	Pork and Beef	Light and fruity flavor.
Fruitwood	Pork, poultry and fish	Wood such as peach, pear and plum produce a mild but sweet smoke with a hint of fruity flavor.
Grapevine	Poultry, game and lamb	Grapevine wood produces a lot of smoke. A little wood goes a long way. It produces a tart flavor that has a hint of fruit.
Hickory	Pork and beef	Hickory produces a very strong flavor so it is recommended to start using only a little amount.
Maple	Pork and Poultry	Light and sweet.
Mesquite	Beef, chicken and fish	This wood burns very hot so be aware. Much like hickory, mesquite produces a strong flavor.
Oak	Red meats, game, ribs and fish	Another wood that produces a heavy smoke. Start slow with this wood.
Pecan	Ribs and red meat	Produces a light smoke that offers a sweet and nutty flavor.

## SUGGESTED SMOKING AND MEAT TEMPERATURES

Please understand that these are only guidelines. All smokers are different. Take into consideration other variables such as weather conditions, wind, ambient temperature, etc. and things can vary by as much as an hour or more.

Learn to tell doneness visually as well as with temperature and time and you will be a much better chef with the smoker.

For more information on food safety call: USDA Meat and Poultry Hotline at 1-888-MPHOTLINE (888-674-6854) In Washington, DC  
 Or E-mail: [mphotonline.fsis@usda.gov](mailto:mphotonline.fsis@usda.gov)  
 Or visit the USDA website at [www.fsis.usda.gov](http://www.fsis.usda.gov)

	Suggested Smoking Temperatures	Safe Minimum Food Temperatures
<b>Meat, Poultry, Fish</b>		
<b>Beef, veal and lamb (pieces and whole cuts)</b>		
Medium-rare	225°F (107.2°C)	145°F (63°C)
Medium	225°F (107.2°C)	160°F (71°C)
Well done	225°F (107.2°C)	170°F (77°C)
<b>Pork (ham, pork loin, ribs)</b>		
Pork (pieces and whole cuts)	225 - 240°F (107.2 - 115.6°C)	160°F (71°C)
<b>Ground meat and meat mixtures (burgers, sausages, meatballs, meatloaf, casseroles and mechanically tenderized beef)</b>		
Beef, veal (including mechanically tenderized), lamb and pork	250 - 275°F (121 - 135°C)	160°F (71°C)
Poultry (chicken & turkey)	250 - 275°F (121 - 135°C)	165°F (74°C)
<b>Poultry (chicken, turkey, duck)</b>		
Pieces	250°F (121°C)	165°F (74°C)
Whole	250°F (121°C)	165°F (74°C)
<b>Seafood</b>		
Fish	225 - 240°F (107.2 - 115.6°C)	158°F (70°C)
Shellfish (shrimp, lobster, crab, scallops, clams, mussels and oysters)	225 - 240°F (107.2 - 115.6°C)	165°F (74°C)
<b>Since it is difficult to use a food thermometer to check the temperature of shellfish, discard any that do not open when cooked.</b>		

	Suggested Smoking Temperatures	Safe Minimum Food Temperatures
<b>Game</b>		
<b>Chops, steaks and roasts (deer, elk, moose, caribou/reindeer, antelope and pronghorn)</b>		
Well done	225°F (107.2°C)	170°F (77°C)
<b>Large Game</b>		
Bear, bison, musk ox walrus, etc.	250 - 300°F (121 - 149°C)	165°F (74°C)
<b>Small game</b>		
Rabbit, muskrat, beaver, etc.	225 - 240°F (107.2 - 115.6°C)	165°F (74°C)
<b>Ground Meat</b>		
Ground meat and meat mixtures	250 - 300°F (121 - 149°C)	165°F (74°C)
Ground venison and sausage	250 - 300°F (121 - 149°C)	165°F (74°C)
<b>Game birds/waterfowl (wild turkey, duck, goose, partridge and pheasant)</b>		
Whole	250°F (121°C)	165°F (74°C)
Breasts and roasts	250°F (121°C)	165°F (74°C)
Thighs, wings	250°F (121°C)	165°F (74°C)
Stuffing (cooked alone or in a bird)	250°F (121°C)	165°F (74°C)

## CARE AND MAINTENANCE

---

### AFTER USE SAFETY AND MAINTENANCE

#### **⚠ WARNING ⚠**

- Use caution when lifting and moving the smoker to avoid strain injuries. Two people are recommended to lift or move the smoker.
- **DO NOT** store the smoker near gasoline or other combustible liquids or where combustible vapors may be present. Keep the area around the smoker clear and free of combustible materials and vapors.
- **DO NOT** store this smoker in an area accessible to children or pets. Store the smoker in a dry, protected location.
- **DO NOT** allow anyone to conduct activities around the smoker following use until it has cooled. It is hot during operation and remains hot for a period of time following use.
- **DO NOT** leave hot ashes unattended until the smoker cools completely.
- The smoker becomes extremely hot – allow the smoker to cool completely before handling. Allow the smoker to cool before removing and cleaning the grease pan.
- Dispose of cold ashes by wrapping them in heavy-duty aluminum foil and putting them in a noncombustible container. If you must dispose of the ashes in less time than it takes for them to completely cool, remove the wood chip box from the smoker with heat resistant gloves, place the ashes in heavy-duty foil and soak them completely with water before disposing of them in a noncombustible container. Always use protective oven mitts or heat resistant gloves when accessing the inside of the smoker during and after use.

#### **⚠ CAUTION ⚠**

All care and maintenance procedures are to be performed while the smoker is turned off, unplugged and cooled. Always perform maintenance by a qualified service person.

To clean the inside and outside of the smoker cabinet, simply use a damp cloth. Spray-washing with a water hose is not recommended. Moisture should be wiped away and not allowed to stand inside or on top of the smoker. Once cleaned, you may prefer to lightly coat the interior of the smoker cabinet with cooking oil or cooking spray.

If rust is present on the exterior surface of the smoker, clean the area with steel wool or emery cloth and use heavy-duty, heat-resistant paint.

NEVER apply additional paint to the interior of the smoker.

## TROUBLESHOOTING

If you have any questions regarding the product, please call customer service at 1-877-447-4768, 8:00 a.m. – 4:30 p.m., CST, Monday – Friday.

PROBLEM	POSSIBLE CAUSE	CORRECTIVE ACTION
<p><b>No heat from smoker</b></p>	<ul style="list-style-type: none"> <li>• Smoker is turned off</li> <li>• No power</li> <li>• Faulty controller or heating element</li> </ul>	<ul style="list-style-type: none"> <li>• Turn on the smoker</li> <li>• Check for any tripped circuit breakers and reset the breaker, if needed.</li> <li>• Check for faulty or tripped GFI (Ground Fault Interrupter) at the outlet. Reset the GFI or replace, if needed.</li> <li>• If breaker or GFI continues to trip, use a different outlet on a separate breaker circuit.</li> <li>• Try another working appliance in the outlet.</li> <li>• Replace controller or heating element.</li> </ul>
<p><b>Circuit breaker trips or fuse blows</b></p>	<ul style="list-style-type: none"> <li>• Another appliance is plugged into the same circuit as the smoker (too many appliances using the same circuit).</li> <li>• Moisture or water in the controller, cord connection or outlet connection</li> <li>• Damaged or frayed cord</li> <li>• Damaged electrical connection</li> </ul>	<ul style="list-style-type: none"> <li>• Find another outlet on a separate circuit.</li> <li>• Keep all connections dry and free from moisture. DO NOT use this appliance in the rain or when snow is falling.</li> <li>• Turn the smoker off, unplug the smoker and check the cord for damage. Replace, if needed.</li> <li>• Replace controller.</li> </ul>
<p><b>Smoker does not generate enough heat</b></p>	<ul style="list-style-type: none"> <li>• Smoker was not pre-heated sufficiently or temperature was set too low</li> <li>• Door left open or unlatched</li> <li>• Improper extension cord</li> </ul>	<ul style="list-style-type: none"> <li>• Pre-heat for 15-20 minutes. Increase temperature settings via controller.</li> <li>• Close the door and latch the door before use.</li> <li>• Use cord rated for outdoor use at 15 amps.</li> </ul>
<p><b>Very little or no smoke coming from smoker</b></p>	<ul style="list-style-type: none"> <li>• Not enough wood chips</li> <li>• Wood chips are too small</li> </ul>	<ul style="list-style-type: none"> <li>• Check wood chip level. Wood chip box should be at least <math>\frac{3}{4}</math> full.</li> <li>• To generate proper amounts of smoke, wood chips should be at least 1”-3” (2.5cm-7.6cm) and no thicker than <math>\frac{1}{4}</math>” (0.6cm). Wood shavings and wood chunks are not recommended. DO NOT use charcoal.</li> </ul>

## TROUBLESHOOTING

PROBLEM	POSSIBLE CAUSE	CORRECTIVE ACTION
<b>Flare-ups</b>	<ul style="list-style-type: none"><li>• Meat contains excessive amounts of fat</li><li>• Cooking temperature is too high</li><li>• Grease build-up</li></ul>	<ul style="list-style-type: none"><li>• Trim the appropriate amount of fat before cooking.</li><li>• Lower the temperature as needed.</li><li>• Clean the smoker, according to the instructions.</li></ul>
<b>Persistent grease fire</b>	<ul style="list-style-type: none"><li>• Too much build-up on grease drip tray and/or grease cup</li></ul>	<ul style="list-style-type: none"><li>• Turn off the smoker and open the door to allow the fire to burn out. <b>DO NOT use water to extinguish the fire. Personal injury my result.</b> Allow the smoker to completely cool before cleaning the tray and cup.</li></ul>