

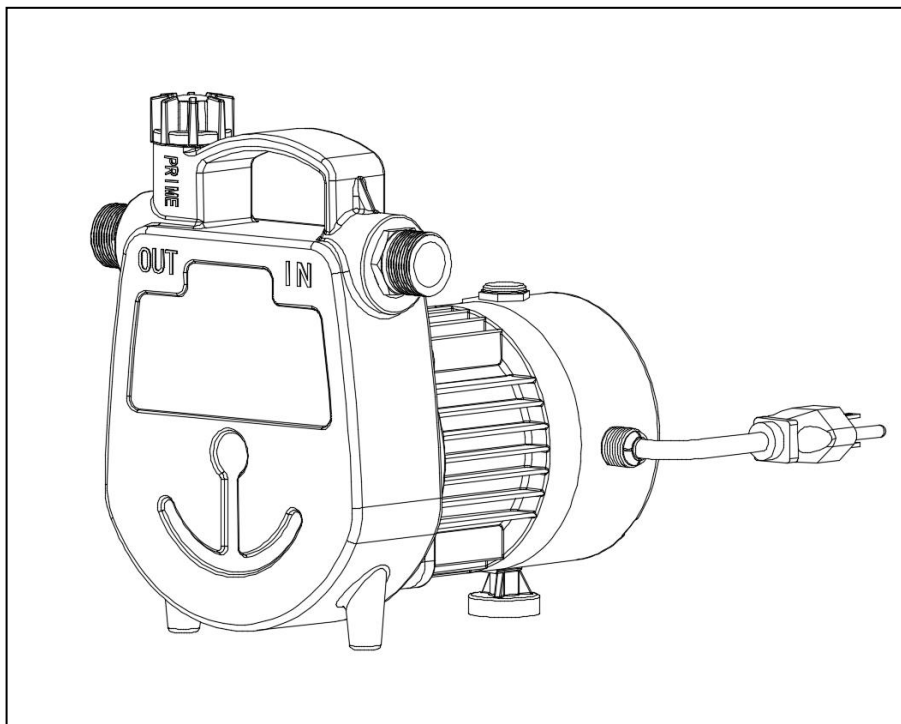

# OWNER'S MANUAL

## CAST IRON TRANSFER PUMP

Ultra-quiet and Efficient Operation



Questions, problems, missing parts? Before returning to the store call

K2 Customer Service 8 a.m. - 6 p.m., EST, Monday-Friday

**1-844-242-2475**

[www.K2pumps.com](http://www.K2pumps.com)

# PERFORMANCE

Model	HP	GPH of Water @ Total discharge pressure psi					Max. discharge pressure
		0	10	20	30	40	50PSI
UTT05001K	1/2	1350	1100	900	650	360	

# SAFETY INSTRUCTIONS

**This pump is non-submersible and should only be used with clear water.**

## Before start-up:

The pump must be plugged into a GFCI protected outlet which has been installed according to the National Electric Code and all local codes. The outlet must have a supply voltage of 120 VAC at 60 Hz.

## DANGER

**Failure to follow these warnings will result in death or serious injury and/or property damage.**

### ELECTRICAL SHOCK HAZARD.

This pump is non-submersible. Keep the motor dry at all times. Do not wash the motor or submerge the pump in water. Protect the motor from wet weather. Do not allow any part of cord or receptacle ends to sit in water or in damp locations.

### FIRE/EXPLOSION HAZARD.

Pump clear water only with this pump. Do not pump chemicals, corrosive liquids, flammable or explosive fluids such as gasoline, fuel oil, kerosene, etc. Do not use in a flammable and/or explosive atmosphere.

## WARNING

**Hazardous Voltage, can shock, burn or cause death.**

### RISK OF ELECTRIC SHOCK.

1. BE CERTAIN the pump is unplugged before you install, service, or maintain the pump. Never handle a pump with wet hands or when standing on wet or damp surface or in water.
2. Connect this pump to a properly grounded 115-volt circuit equipped with a Ground Fault Circuit Interrupter (GFCI) outlet. Never use an extension cord.
3. Before installing this product, have the electrical circuit checked by an electrician to ensure proper grounding. All electrical installations must conform to the National Electric Code and all local codes.
4. These pumps are supplied with a 3-prong grounded plug to help protect you against the possibility of electrical shock. DO NOT UNDER ANY CIRCUMSTANCES REMOVE THE GROUND PIN.
5. Protect electrical cord from sharp objects, hot surfaces, oil, and chemicals. Avoid kinking the cord. Replace pump if cord is damaged.
6. Do not lift the pump by the cord. Always use the handle to lift the pump.
7. This pump is not intended to be permanently installed outdoors. Protect pump from extreme heat, cold, and humidity. This pump is not waterproof and is not intended to be used in showers, saunas, swimming pool areas, or other potentially wet locations. The motor is designed to be used in a clean, dry location with access to an adequate supply of cooling air. Ambient temperature around the motor should not exceed 104°F (40°C).

# WARNING

## PERSONAL INJURY and/or PRODUCT DAMAGE

1. Do not touch the motor when operating. The motor is designed to operate at high temperatures. Turn the pump OFF, unplug, and allow the motor to cool before handling.
2. Do not operate this pump while unattended.
3. Never run pump dry. Pump must be primed before operating.
4. Provide a means of pressure relief if the pump discharge can be shut off or obstructed. Pumps operating with a closed discharge can create hot liquid, which can cause burns.
5. This pump is equipped with an automatic thermal overload and can restart without warning.

## PRE-INSTALLATION

Part	DESCRIPTION	QUANTITY
A	Pump	1
B	Hose Strainer	1

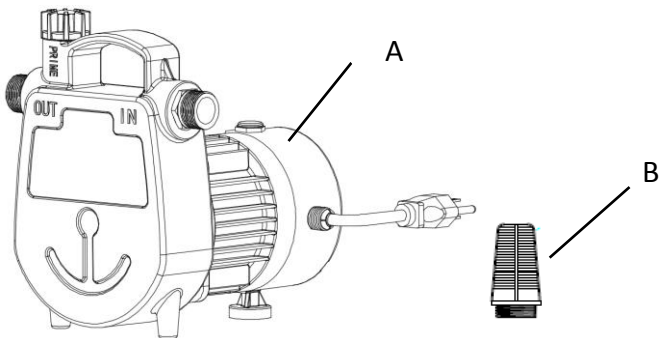

## SPECIFICATIONS

Horsepower	1/2 HP
Electrical Rating	120VAC / 60Hz / 7A
Power Cord Length	10'
Discharge Port	3/4" Garden Hose Thread

# INSTALLATION

This pump should be located on a solid, stable and level surface using:

1. Reinforced heavy-duty hose or plastic pipe for the Inlet Line.
2. 3/4" Standard garden hose for the Discharge Line.

**Please note:**

1. Do not hang the pump by the power cord, inlet pipe or hose. The pump must be placed on a stable surface. To ensure that the pump works properly, keep the suction end of the hose or pipe free from debris and sludge.
2. If the water level is too low, any debris or sludge will dry out and stop the pump from starting. To ensure the pump will start as required, check the pump regularly with start-up tests.

**Areas of use**

1. This pump is designed to pump water only.
2. This pump can be used for general purpose removal or transfer of clear water in household and farming applications.
3. DO NOT use this pump for: continuous run applications, fountain or pond water features, emptying swimming pools or spas, or with septic and sewage systems.

**LOCATION**

Pump (A) should be located within 15 ft. of the water source, and strainer (B) should be used at the end of the inlet line.

**NOTE:** Make sure the inlet hose is NOT coiled or kinked above or below water level. The inlet line may be galvanized pipe, plastic pipe, or reinforced hose. Be sure there are no leaks in the inlet line, as this may reduce pump efficiency or prevent priming. Inlet line should be the same diameter as the discharge line, or larger. DO NOT use regular garden hose on the inlet line as it will collapse during pumping. Standard 3/4 in. garden hose may be used as a discharge line. Keep the total length as short as possible for best performance.

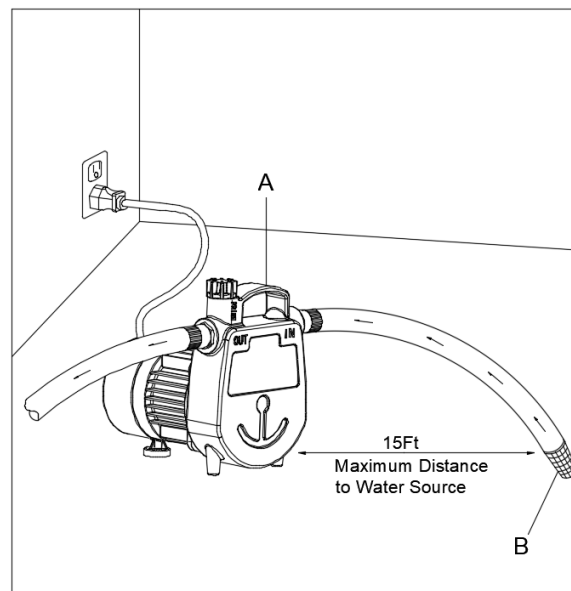

# INSTALLATION INSTRUCTIONS

1. Attach plastic pipe or reinforced heavy-duty hose to the INLET on the pump. Make sure the Inlet connection is air tight. Attach the Hose Strainer to the other end of the pipe or hose to prevent debris from entering the pump.

**NOTE:** Regular garden hose should not be used on the pump Inlet. It will collapse when the pump runs.

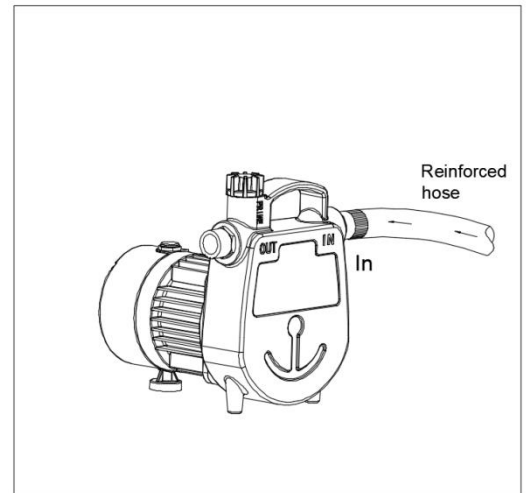

2. Attach a standard 3/4" garden hose to the OUTLET on the pump. Keep the total length of hose as short as possible for best performance. Secure the hose to keep it from moving around.

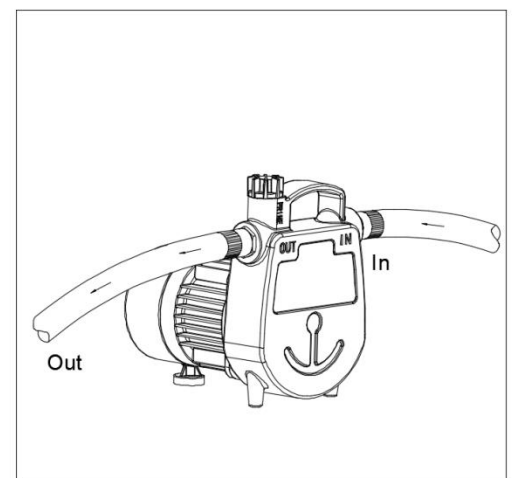

3. Remove priming plug from the top of the pump.

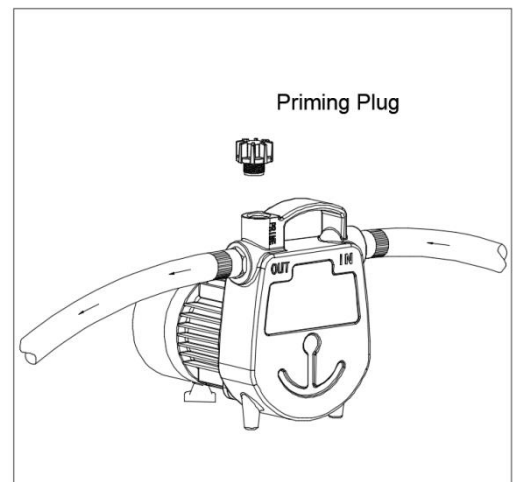

4. Fill pump housing with clean water. Reinstall plug.

**DO NOT RUN DRY.**

**NOTE:** Do not pump sand or other abrasives as this will damage the shaft seal or impeller and void the warranty.

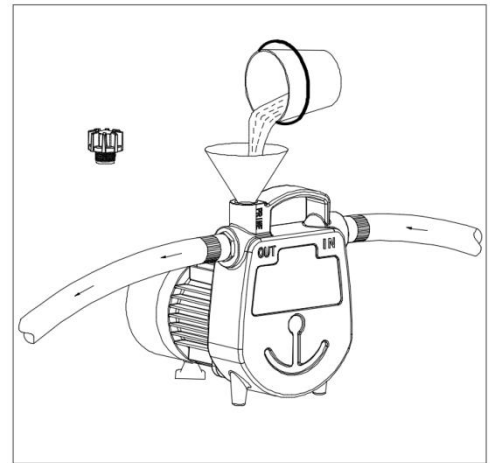

5. For normal water transfer applications, plug in power cord to grounded outlet. Then press the switch on the top of the motor (B), Pump will prime in a few minutes, depending on suction line length.

**Description of the switch:** After connecting the plug, you must press the switch to start the pump. When you stop using it, you need to press the switch again to turn off the pump or unplug the plug directly. Repeat the above operation next time you use it.

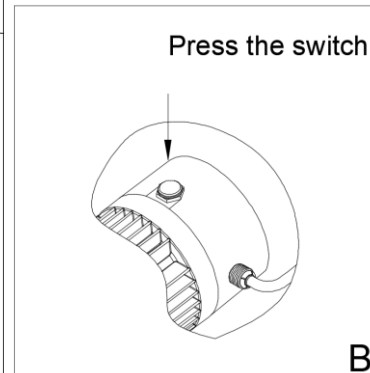
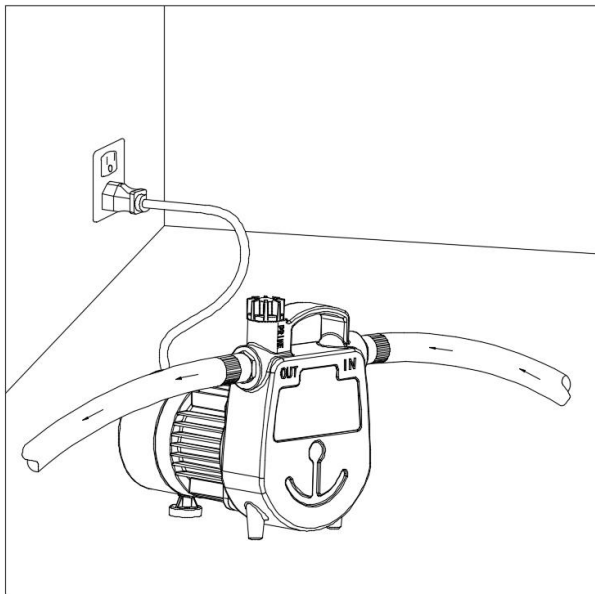

6. If the pump does not pump water after two minutes, turn off the pump and repeat steps 4 through 6.  
**DO NOT RUN DRY.**

# TROUBLESHOOTING

PROBLEM	POSSIBLE CAUSE	CORRECTIVE ACTION
Pump will not begin pumping or retain prime after operating, or stops pumping water.	1. Air leak in suction line.	1. Repair or replace suction line. Make sure fittings are air tight and use thread sealant tape if necessary.
	2. Fittings are not tight.	2. Tighten fittings air tight, using thread sealant tape if necessary.
	3. Hose is kinked or looped.	3. Inspect hose and straighten if needed.
	4. Inlet hose is out of the water.	4. Submerge inlet hose end.
	5. Clogged inlet.	5. Clean inlet.
	6. Inlet lift too high.	6. Lower pump.
	7. Impeller blocked.	7. Remove blockage.
	8. Worn seal.	8. Replace seal.
	9. Collapsed inlet hose.	9. Replace with reinforced hose.
Pump will not start or run.	1. Blown fuse or circuit breaker.	1. If blown, replace with proper sized fuse or reset breaker.
	2. Low line voltage.	2. If voltage is under 104 volts, check wiring size.
	3. Impeller blocked.	3. Remove blockage.
	4. Defective motor.	4. Replace pump.
Flow rate is too low.	1. Piping or hose is kinked or damaged.	1. Clean or replace piping or hose.
	2. Low line voltage.	2. If voltage is under 104 volts, check wiring size.
	3. Too much discharge hose friction.	3. Shorten and/or increase the diameter of the discharge hose.
Seal leaks	1. Worn seal.	1. Replace seal.
	2. Pump head is loose on motor.	2. Ensure proper assembly and check for obstructions. Tighten bolts.
The pump stops during work	1. Insufficient water source leads to no-load protection	1. Check the water source and restart the pump according to the operation steps
	2. The impeller is locked by garbage	2. Remove the pump body and clean up the garbage

## Parts List

Part	Description	Qty.
1	Priming Plug	1
2	O-ring	1
3	Pump Gasket	1
4	Motor	1
5	Spring Washer	4
6	Screw	4
7	Water Retaining Washer	1
8	Mechanical Seal	1
9	Impeller	1
10	Pump Facing	1
11	Rubber Foot	2

## Assembly Diagram

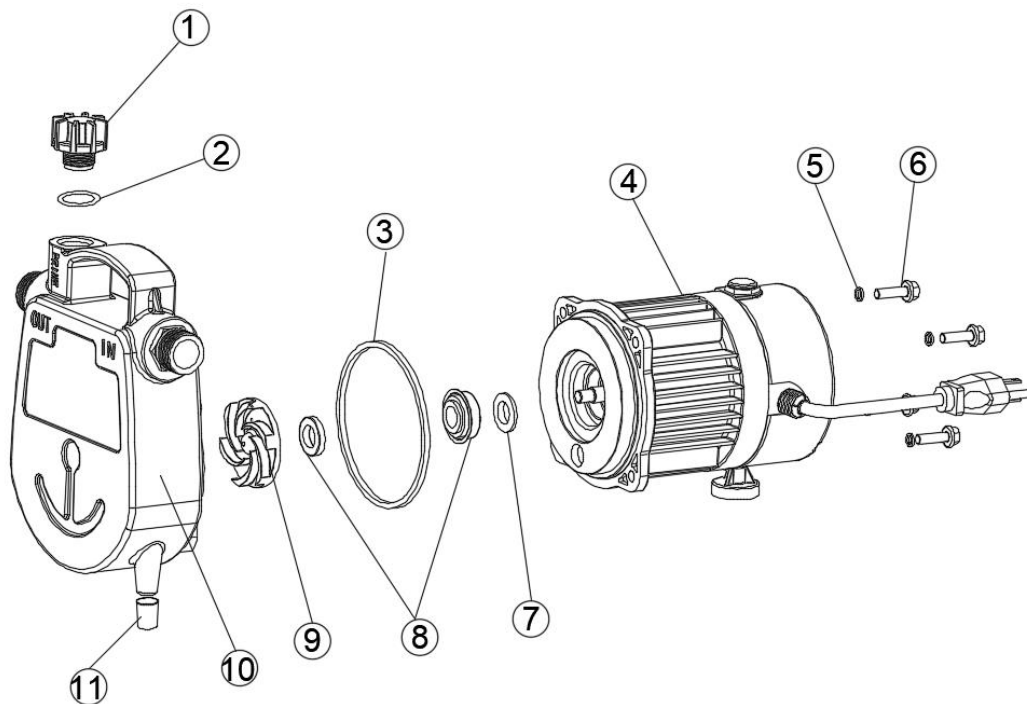



# WARRANTY

## K2 Pumps Limited Warranty

### WHAT THIS WARRANTY COVERS

This Limited Warranty is effective September 1, 2020 and replaces all undated warranties dated prior to September 1, 2020.

K2 Pumps (K2) warrants to the original consumer purchaser (You) that its products are free from original defects in material and workmanship for at least one year (warranty varies depending on model; see box or K2 website for specific warranty information) from the date of purchase (the Warranty Period). Repair Parts and Accessories are warranted for 90 days from the date of purchase. During the Warranty Period, K2 will repair or replace, at no cost to you, products that have been examined by K2 and found to be defective in materials or workmanship.

***Do not return product to the retail store.***

***For technical support and parts, call K2 Customer Service at 844-242-2475.***

### WHAT THIS WARRANTY DOES NOT COVER

This Warranty does not cover use of the product in a non-residential application, improper installation and/or maintenance of the product, damage due to misuse, acts of God, nature, vandalism or other acts beyond control of K2, owner's acts or omissions, use outside the country in which the product was initially purchased and resale of the product by the original owner. This warranty does not cover pick up, delivery, transportation or house calls. However, if you mail your product to a K2 Sales and Service Center for warranty service, cost of shipping will be paid one way. This warranty does not apply to products purchased outside of the United States, including its territories and possessions, outside of U.S. Military Exchange and outside of Canada. This warranty does not cover products purchased from a party that is not an authorized retailer, dealer or distributor of K2 products.

### OTHER IMPORTANT TERMS

This warranty is not transferable and may not be assigned. This Warranty shall be governed and construed under laws of the state of Michigan. The Warranty Period will not be extended by any replacement or repair performed under this Warranty. THIS WARRANTY IS THE EXCLUSIVE WARRANTY AND REMEDY PROVIDED BY K2. ALL OTHER WARRANTIES, EXPRESSED OR IMPLIED, INCLUDING WARRANTIES OR MERCHANTABILITY OR FITNESS FOR PARTICULAR PURPOSE, ARE DISCLAIMED. IN NO EVENT WILL K2 BE LIABLE FOR ANY SPECIAL, INDIRECT, INCIDENTAL OR CONSEQUENTIAL DAMAGES OF ANY KIND OR NATURE TO OWNER OR ANY PARTY CLAIMING THROUGH OWNER WHETHER BASED IN CONTRACT, NEGLIGENCE, TORT, OR STRICT PRODUCTS LIABILITY OR ARISING FROM ANY CAUSE WHATSOEVER. Some states do not allow for the exclusion of consequential damages, so the above exclusion may not apply to you. This warranty gives you specific rights. You may also have other rights that vary from state to state.

**GP Enterprises Co., Ltd. 1436 Brook Drive, Downers Grove, IL 60515**

**Phone: 844-242-2475 / Web: [www.K2Pumps.com](http://www.K2Pumps.com)**