



General Guidelines ⚠

- It is the user's responsibility to read and follow all instructions.
- Keep these instructions with the product at all times and review before each use.
- It is the responsibility of this product's owner to furnish the instructions to any person that borrows or purchases the product.
- Inspect the product before use to ensure it is assembled properly and all parts are in safe working order and free of defects.
- Never modify this product in any way.
- All circumstances cannot be addressed in these instructions. Please use common sense and practice general safety measures when using this product.
- Parts and/or instructions are subject to change without notice.

Safety ⚠

- Distribute load evenly
- Do not exceed the lesser of (1) hitch manufacturer's tongue weight rating, (2) vehicle manufacturer's rear load limit, or (3) 500 lbs total cargo.
- Do not transport people or animals on the carrier
- Do not allow cargo to block taillights/vehicle safety equipment
- Securely strap all cargo to the carrier and check frequently during travel
- Do not carry loads that are wider than the carrier platform
- Carrier hitch pins and cotter pins must be secured before each use
- Be certain to secure all items to the carrier
- Do not transport flammable/combustible items on the carrier
- Trailer hitch pin sold separately
- Be sure to attach reflective stickers

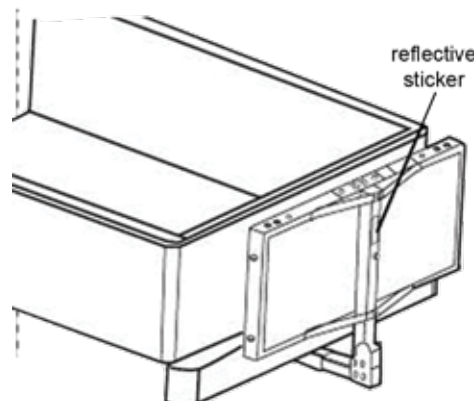
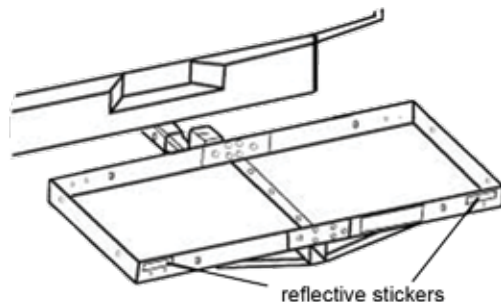

Parts

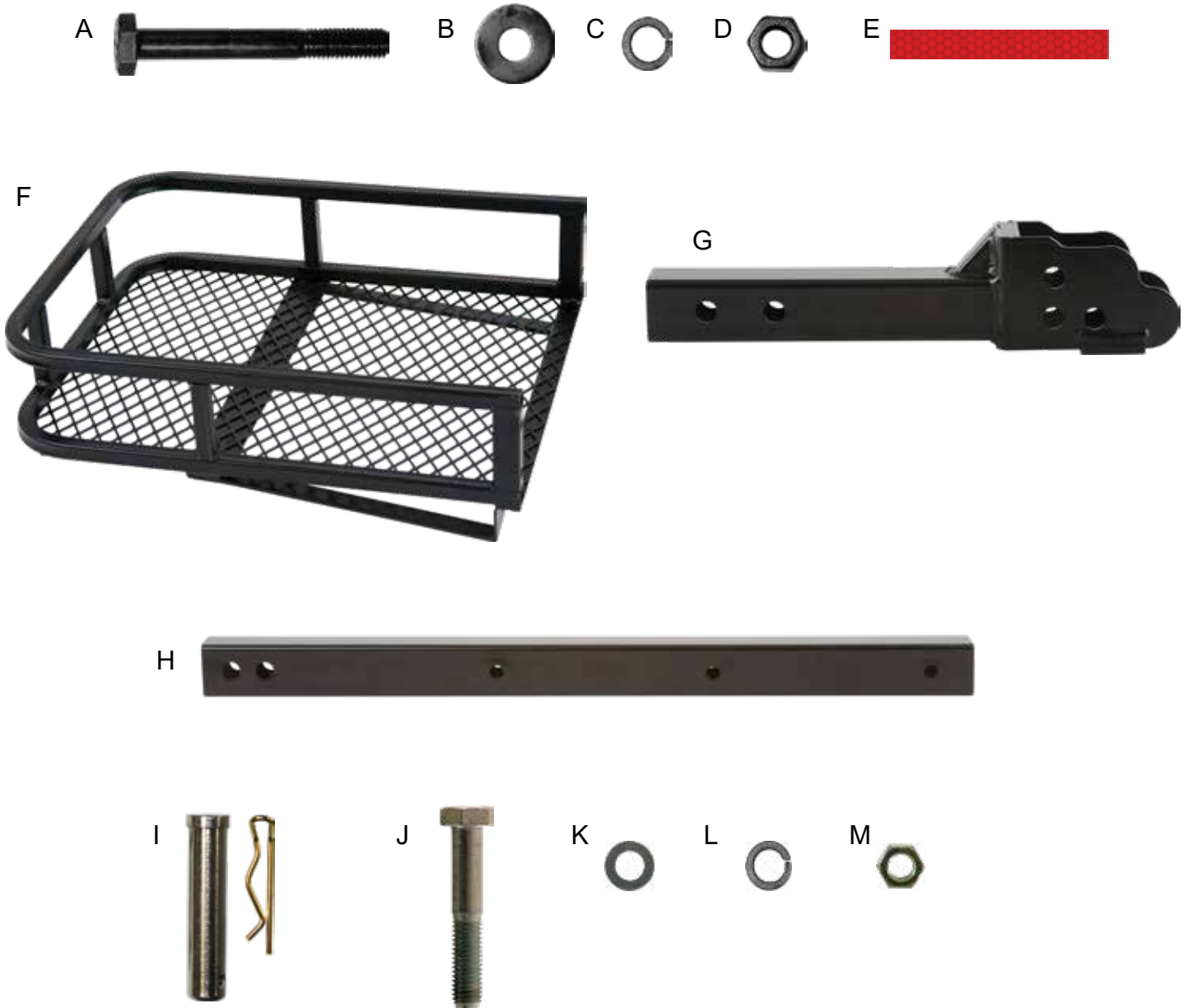

Part	Description	Quantity
A	M10x80 bolt	7
B	M10 Washer	14
C	M10 Lock Washer	7
D	M10 Nut	7
E	Reflective Sticker	3
F	Cargo Carrier Basket Section	2
G	Folding Receiver Tube w/ Bracket	1

Part	Description	Quantity
H	Main Tube	1
I	Pin	1
J	Pivot Bolt	1
K	Pivot Bolt Washer	2
L	Pivot Bolt Lock Washer	1
M	Pivot Bolt Nut	1

*Trailer hitch pin not included

Basket Assembly

Step 1. Slide the cargo carrier sections (F) together until the bolt holes line up. It may help to prop up one or both ends to keep the holes aligned.

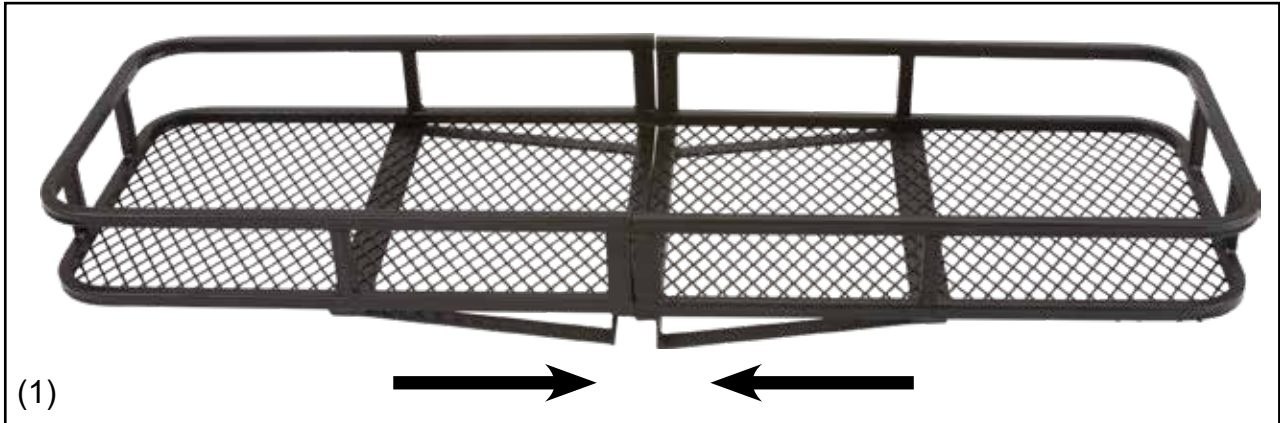

Step 2. Secure the sections with four M10x80 bolts (A), washers (B), lock washers (C), and nuts (D).

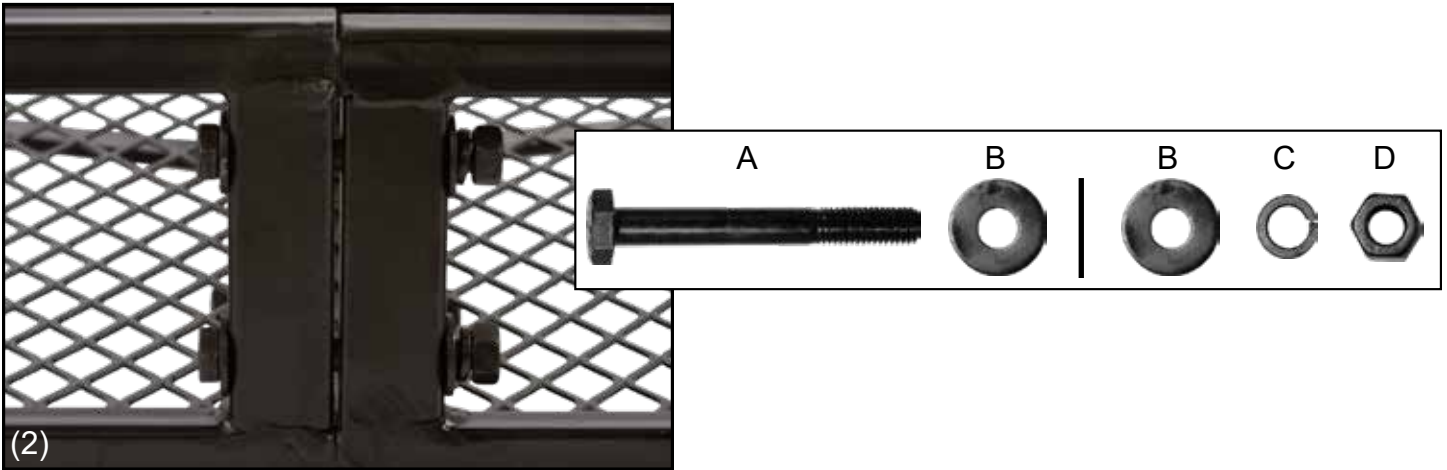

Step 3. Flip the carrier over to install the main tube (H). Secure with three M10x80 bolts (A), washers (B), lock washers (C), and nuts (D).

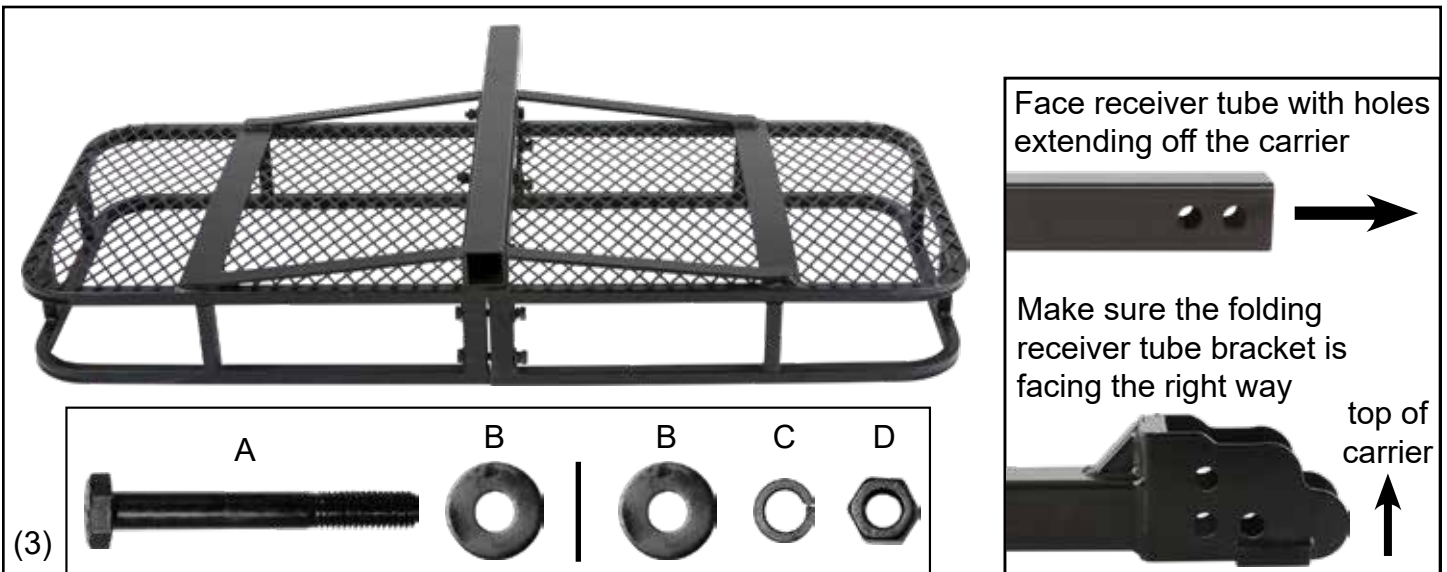

Receiver Tube Assembly

Step 1. Insert the bracket end of the folding receiver tube (G) into the main tube (H).



Step 2. Secure the folding receiver tube with the pivot bolt* and pin (I) to the main tube bracket.

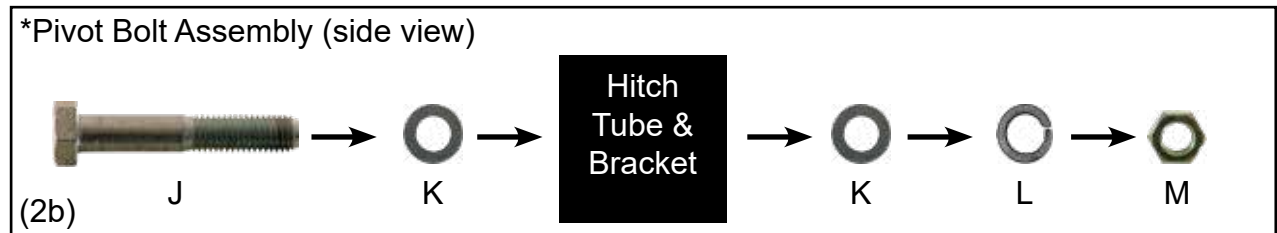
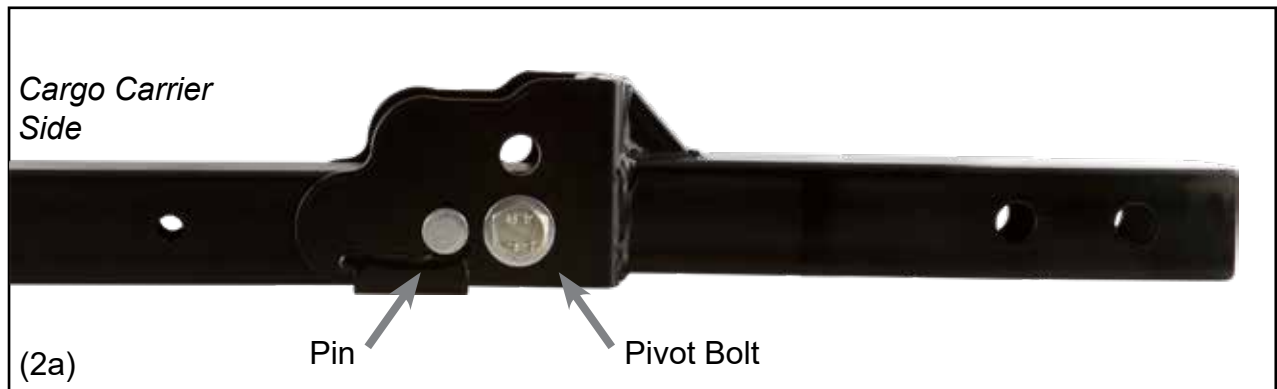

Step 3. To fold the carrier vertically, remove the pin and fold the carrier. Align the holes and reinstall the pin in the top folding receiver tube bracket hole.



Product Warranty and Liability

GENERAL PRODUCT WARRANTY: Products purchased from the Authorized Dealer (original place of purchase) or Merchant (“Dealer”) will be free of defects in material and workmanship at the time of receipt, and will meet the specifications stated at the place of purchase transaction or online at the Dealer’s website, under normal use and service when correctly installed, operated and maintained. This product warranty is effective for the period of time stated below, unless otherwise stated in the product instructions or depicted in the product advertisement. **All Authorized Dealer warranties are NON-TRANSFERABLE** and cover only the original end purchaser. This limited warranty does not cover products purchased through non-authorized dealers. Non-authorized dealer receipts are not accepted for warranty verification.

*****Warranty claims must be made directly to the original place of purchase.*****

WARRANTY PERIOD: This warranty remains in force for one year from the date of the product’s accepted delivery. The Authorized Dealer offers a one year manufacturer’s warranty for most products unless otherwise specified on the product advertisement.

WARRANTY SERVICE: The Authorized Dealer will replace any defective or malfunctioning part at no charge, including payment of the shipping costs of parts or replacement product to and from the manufacturer. The purchaser is responsible for labor charges. If the product does not meet specifications as depicted in the advertisement, the Authorized Dealer will refund the full purchase price of the product.

Questions regarding the warranty on a specific product and warranty claims should be directed to the Authorized Dealer with whom the purchase transaction was made.

WARRANTY LIMITATIONS: The above warranty does not apply to products that are repaired, modified or altered by any party other than the Authorized Dealer; are subjected to unusual physical stress or conditions (such as overloaded ramps or corrosion), natural disaster, governmental actions, wars, strikes, labor disputes, riots, theft, vandalism, terrorism or any reason beyond reasonable control; are damaged due to improper installation, misuse, abuse, accident or negligence in use, storage, transportation or handling, or tampering; or to products that are considered consumable items or items requiring repair or replacement due to normal wear and tear.

Product should be inspected prior to signing for delivery. Product damage incurred during shipping, unless noted on the Bill of Lading at the time of delivery, renders this warranty void.

LIMITED LIABILITY: In no event shall THE AUTHORIZED DEALER be liable to the purchaser or any third party for any indirect, incidental, consequential, special, exemplary or punitive damages arising out of the use of the product, including, without limitation, property damage, loss of value of the product or any third party products that are used in or with the product, or loss of use of the product or any third party products that are used in or with the product.

