

Installation Instructions
Instructions d'installation
Instrucciones para la instalación

Ductless Recirculating Kit
Trousse de conversion en hotte à recyclage
Kit de conversión sin tubos

READ AND SAVE THESE INSTRUCTIONS
LISEZ CES INSTRUCTIONS ET CONSERVEZ-LES
LEA Y GUARDE ESTAS INSTRUCCIONES

Installation Instructions



WARNING:

- Read and Save These Instructions.
- Approved for Residential Appliances only.
- PLEASE READ ENTIRE INSTRUCTIONS BEFORE PROCEEDING.
- INSTALLER: Please leave these Instructions with this unit for the owner.
- OWNER: Please retain these instructions for future reference.
- Turn off power circuit at service panel and lock out panel before installing this kit to the appliance.
- Installation must comply with all local codes.

PACKAGING CONTENTS

- Air deflector
- Charcoal Filter
- 4 Assembly screws

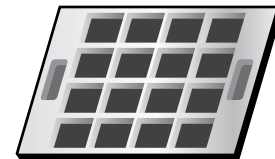
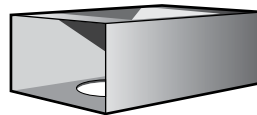

INSTALLATION INSTRUCTIONS

- 1** After the duct cover bracket has been installed on the wall (Refer to Installation Instructions in the Hood Manual), assemble the air deflector to the duct cover bracket with 4 assembly screws, as is shown in image 1.
- 2** Measure from the bottom of the air deflector to the bottom of the hood outlet, as is shown in image 2. Cut the ductwork at the measured dimension.

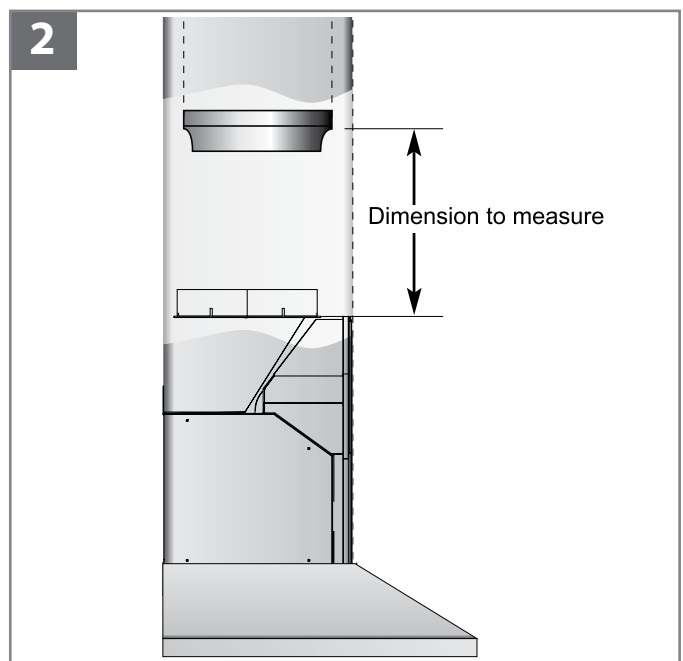
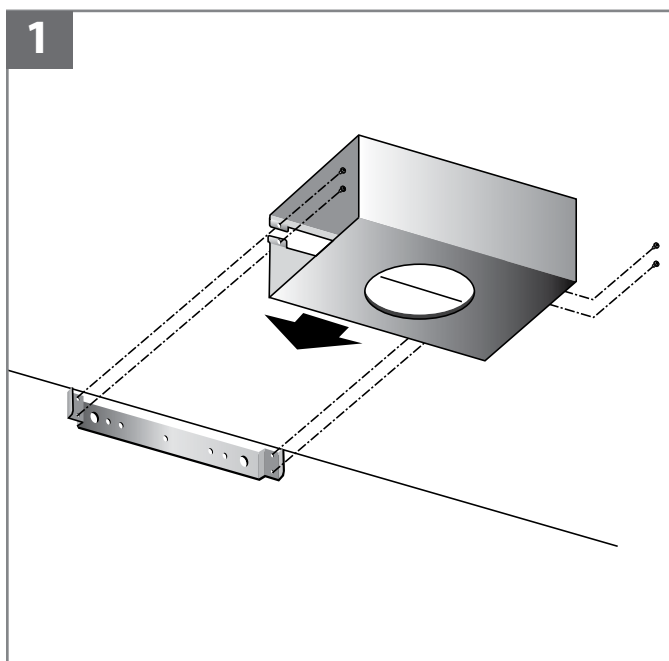

Installation Instructions

INSTALLATION INSTRUCTIONS

- 3 Uninstall the air deflector removing the 4 assembly screws.
- 4 Slip the duct onto the bottom of the deflector.
- 5 Place the assembled deflector and duct work over the exhaust outlet from the hood.
- 6 Assemble the air deflector to the duct cover bracket, with the 4 assembly screws provided.
- 7 Use duct tape to seal the deflector and the exhaust outlet from the hood, as is shown in the following image. The duct tape must be approved for this application

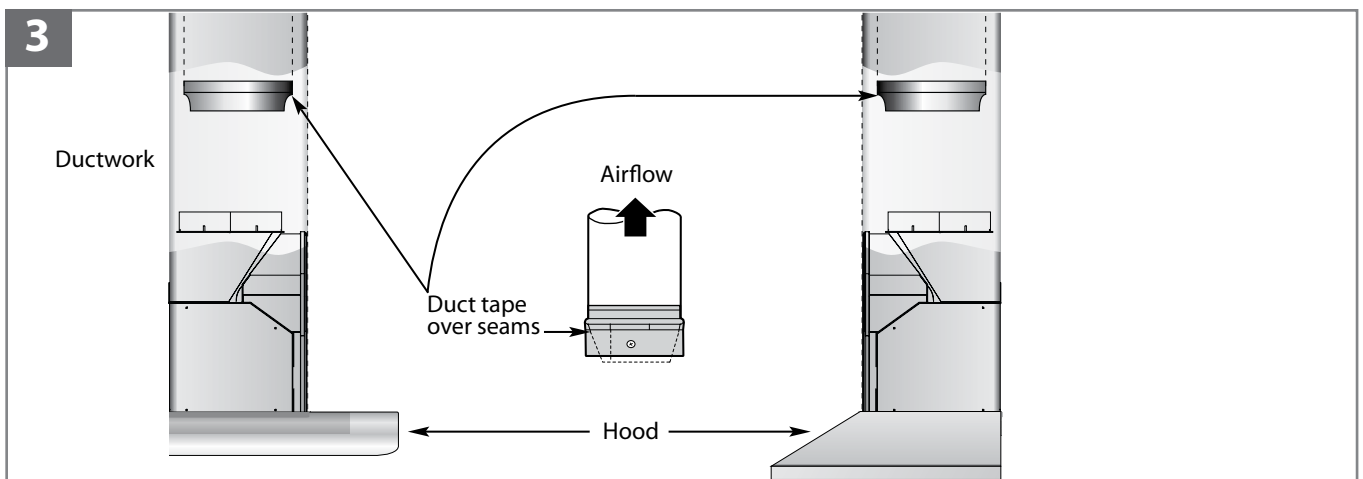

CHARCOAL FILTER INSTALLATION

- Remove the grease filter of the hood.
- Position the charcoal filter inside the structure of the motor as shown in picture b.
- Reinstall the grease filter onto the bottom of the hood.

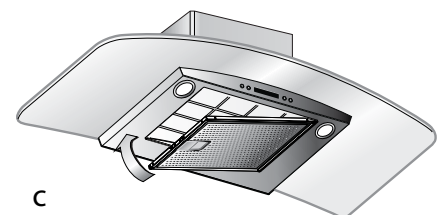
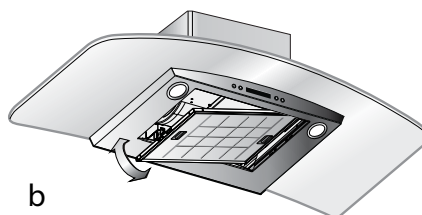
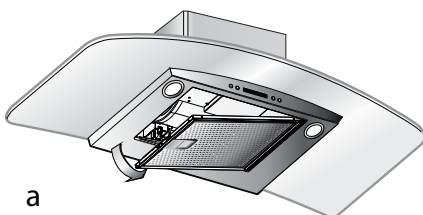
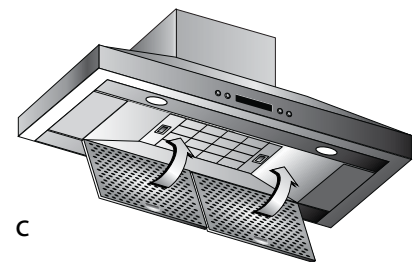
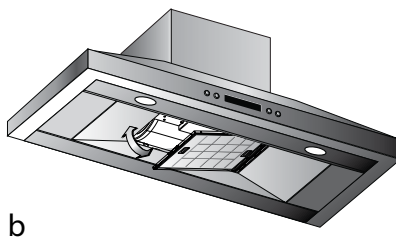
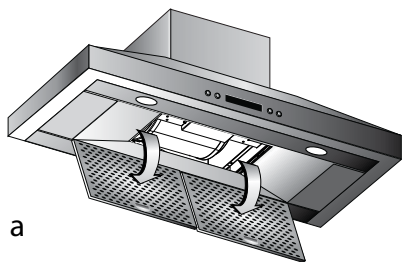

Instructions d'installation

AVERTISSEMENT:

- Lire et Conserver ces Instructions.
- Approuvé pour Utilisation Domestique uniquement.
- LIRE TOUTES LES INSTRUCTIONS AVANT UTILISATION.
- INSTALLATEUR: Laisser ces Instructions avec l'appareil pour l'utilisateur.
- PROPRIETAIRE: Garder ces Instructions pour une consultation future.
- Couper l'alimentation électrique au tableau des fusibles et verrouiller le panneau avant d'installer ce kit à l'appareil.
- L'installation doit être conforme aux réglementations locales.

CONTENU DE L'EMBALLAGE

- Déflecteur d'air
- Filtre au charbon
- 4 Vis d'assemblage

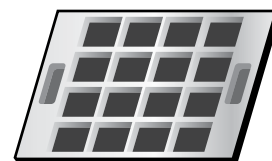
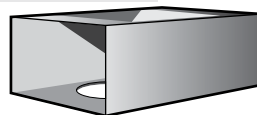

INSTRUCTIONS D'INSTALLATION

- 1 Après que l'étrier de support du conduit ait été fixé sur le mur (se référer aux Instructions d'Installation dans le Manuel de la Hotte), assembler le déflecteur d'air à l'étrier de support du conduit, comme indiqué à la figure 1.
- 2 Prendre la mesure depuis le fond du déflecteur d'air jusqu'au fond de la sortie de la hotte, comme indiqué sur la figure 2. Couper le conduit de cheminée à la dimension mesurée.

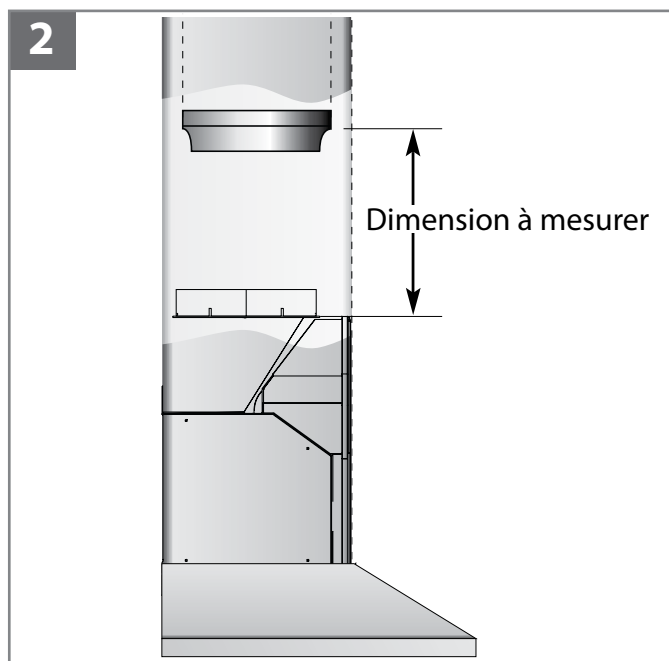
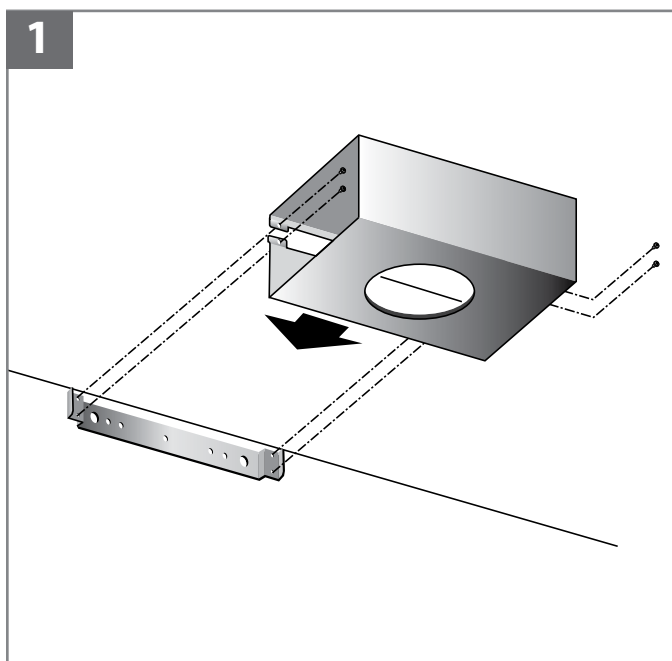

Instructions d'installation

INSTRUCTIONS D'INSTALLATION

- 3 Enlever le déflecteur d'air en dévissant les 4 vis d'assemblage.
- 4 Faire glisser le conduit au fond du déflecteur.
- 5 Placer le déflecteur assemblé et le conduit de cheminée sur la sortie d'évacuation de la hotte.
- 6 Assembler le déflecteur d'air à l'étrier du support de conduit, avec les 4 vis d'assemblage fournies.
- 7 Utiliser le ruban pour sceller le déflecteur et la sortie d'évacuation de la hotte, comme indiqué dans la figure suivante. Le ruban doit être homologué pour ce type d'application.

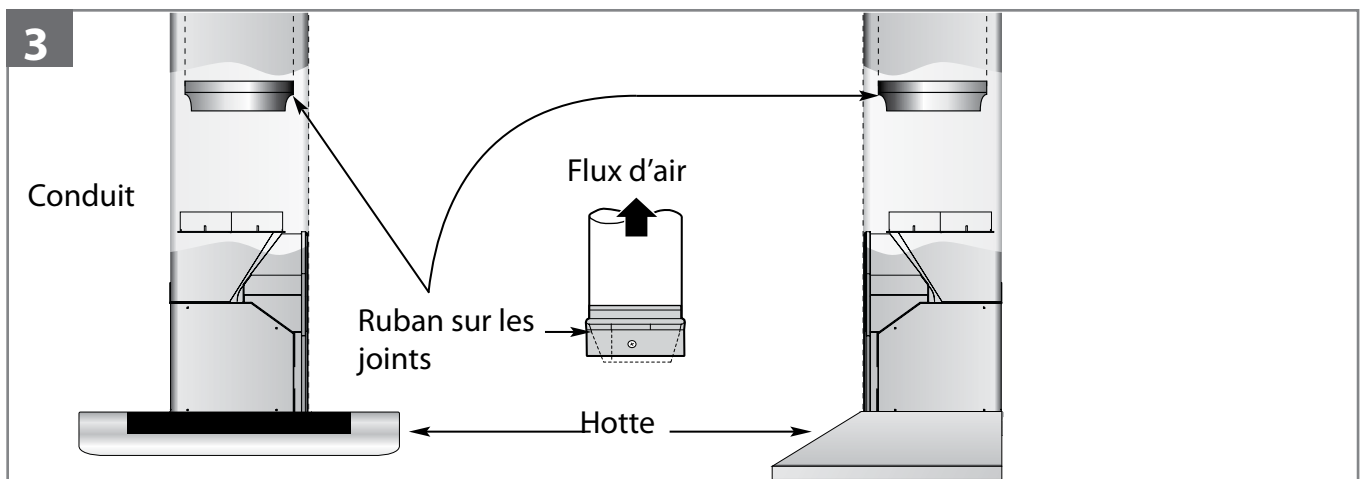

INSTALLATION DU FILTRE A CHARBON

- Enlever les filtres anti-graisse de la hotte.
- Placer le filtre au charbon à l'intérieur de la structure du moteur comme indiqué dans la figure b.
- Replacer le filtre anti-graisse sur le fond de la hotte.

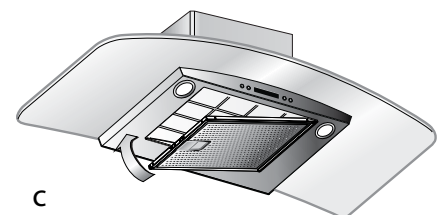
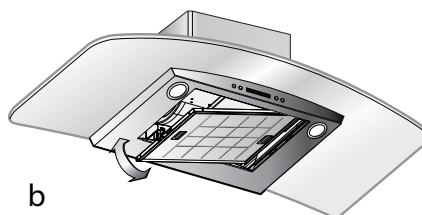
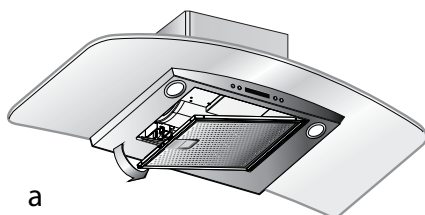
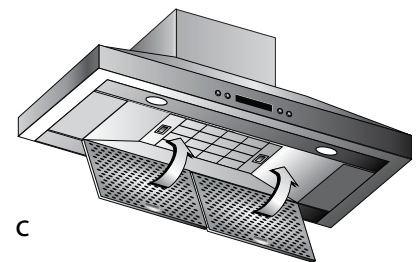
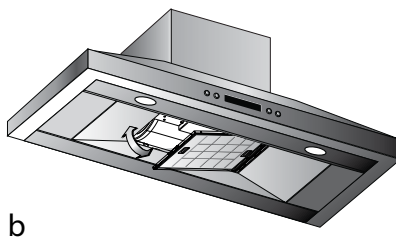
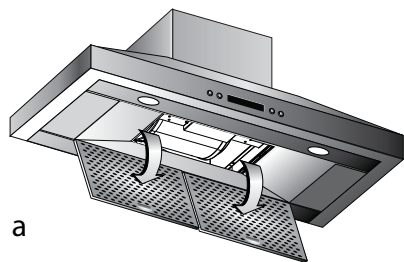

Instrucciones para la Instalación



PRECAUCIÓN:

- Lea y guarde estas instrucciones.
- Aprobado para electrodoméstico residencial únicamente.
- Por favor lea completamente estas instrucciones antes de proceder.
- Instalador: Por favor deje estas instrucciones al propietario.
- Propietario: Por favor mantenga estas instrucciones para futuras referencias.
- Desconecte esta unidad del tablero de control eléctrico y asegure el panel de control antes de instalar este accesorio a la campana.
- La instalación debe cumplir con todos los estatutos locales.

CONTENIDO EN EMPAQUE

- Deflector de aire
- Filtro de carbón
- 4 Tornillos de ensamble

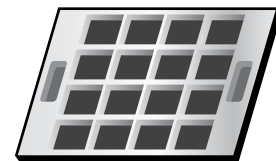
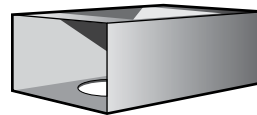

INSTRUCCIONES PARA INSTALACIÓN

- 1** Después de que el soporte para cubre ductos ha sido instalado en la pared (Haga referencia al manual de instalación de la campana), ensamble el deflector de aire en el soporte de cubre ductos, con 4 tornillos de ensamble, tal y como se muestra en la figura 1.
- 2** Mida desde la parte inferior del deflector de aire a la parte inferior del escape en la campana. Corte el ducto a la dimensión medida, como se muestra en la figura 2.

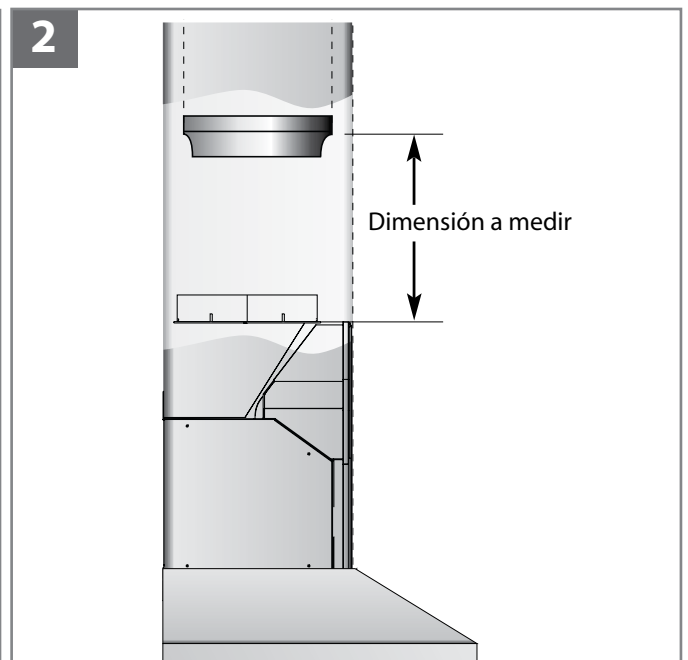
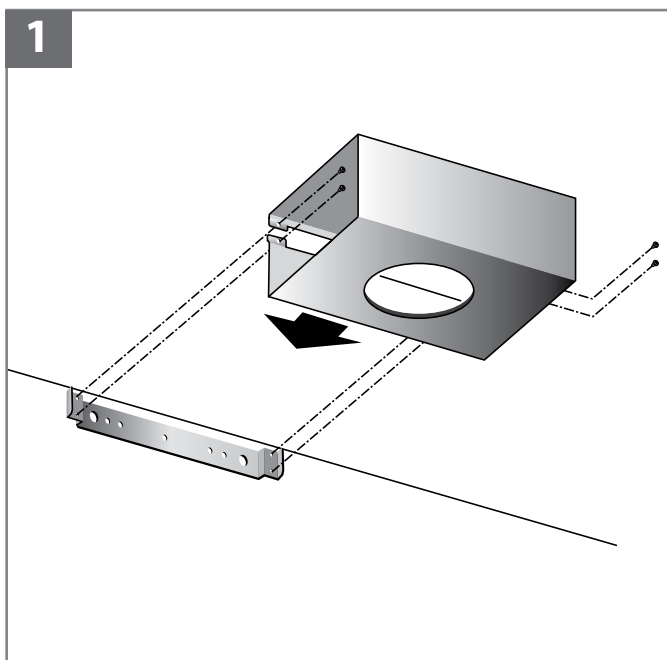

Instrucciones para la Instalación

INSTRUCCIONES PARA INSTALACIÓN

- 3** Desinstale el deflector de aire removiendo los 4 tornillos de ensamble.
- 4** Deslice el ducto en la parte inferior del deflector.
- 5** Posicione el ensamble del deflector de aire y ducto sobre el escape de aire en la campana.
- 6** Ensamble el deflector de aire en el soporte de cubre ductos utilizando los 4 tornillos de ensamble.
- 7** Utilice cinta especial para sellar las uniones del ducto al deflector y al escape de la campana, como se muestra en la siguiente figura. La cinta para sellar el ducto deber estar aprobada para la aplicación.

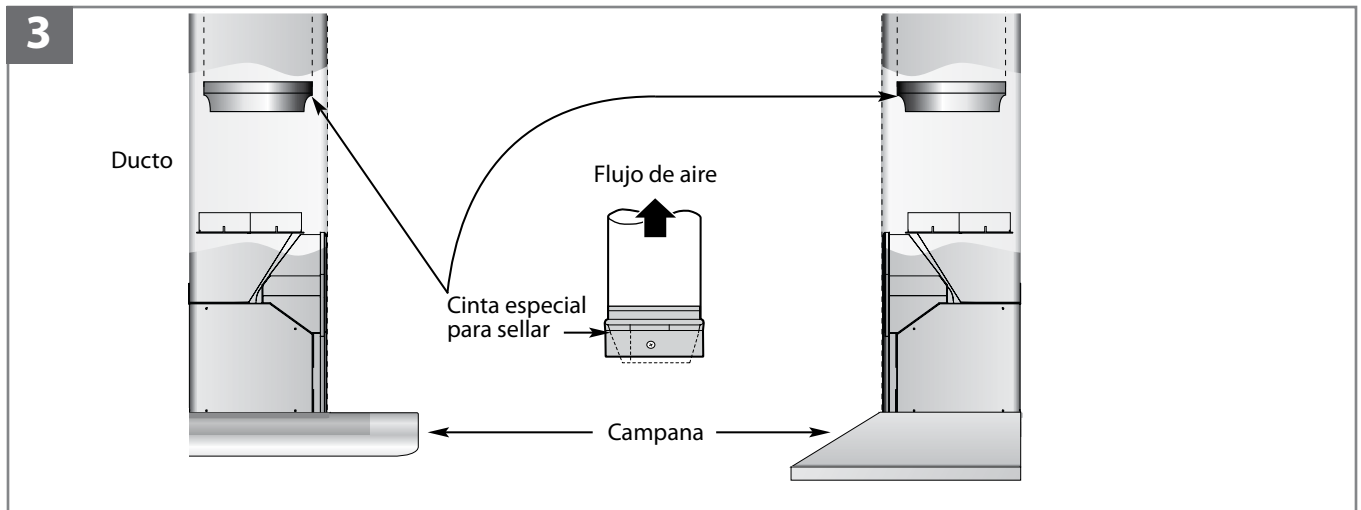

INSTALACIÓN DEL FILTRO DE CARBÓN

- Remueva el filtro de grasa de la campana.
- Posicione el filtro de carbón dentro de la estructura del motor como se muestra en la figura b.
- Reinstale el filtro de grasa en la campana.

