



America's Favorite Garage Doors®

# INSTALLATION & MAINTENANCE INSTRUCTIONS



## RESIDENTIAL GARAGE DOORS

### MODEL **HDS**

8' x 6'6"    8' x 7'    9' x 7'

### MODELS **75, HDB**

8' x 7'    9' x 7'

### MODELS **HDB with windows**

9' x 7'

### MODELS **HDBL**

8' x 7'

### MODEL **84A solid & with windows**

8' x 7'    9' x 7'

Serial Number: \_\_\_\_\_

*Located on label of interior door surface.*

PID Number: \_\_\_\_\_

**Thank you for your purchase.**  
**For questions contact 877-526-2050**  
**or email [BPCinfo@clopay.com](mailto:BPCinfo@clopay.com)**

### REPLACEMENT PARTS:

Please contact Clopay Customer Service.

Be sure to provide the following:

- Part name
- Model and size of door
- Order number or door serial number

### INSTALLATION VIDEO:

<https://www.clopaydoor.com/residential/buyingguide/residential-installation-videos>

or scan the QR code on the right.



#### FRANÇAIS

La version française de ce supplément peut être accédée en ligne à l'adresse suivante: <http://www.clopaydoor.com/owners-manuals>



#### ESPAÑOL

Se puede acceder a la versión en español del presente suplemento en la siguiente dirección: <http://www.clopaydoor.com/owners-manuals>

## PRE-INSTALLATION CHECKLIST

### BEFORE REMOVING YOUR OLD DOOR:

- Verify you have all required parts and materials required for installation.
  - Door Components (See Page 4).
  - Spring Components (See Page 21).

**If missing parts or damaged sections, please call 877-526-2050 within 14 days of purchase and parts will be replaced promptly. DO NOT RETURN DOOR TO STORE.**

- Read instructions completely and/or watch installation video.

- Verify appropriate amount of headroom to install door. This door requires a minimum of 12" above the door opening (See Appendix A for details).
- Be sure to allow enough time to complete door installation. Garage will be open and unsecured during installation and will not be able to be used until tracks are installed.
  - Removing existing door will take approximately 1–3 hours.
  - Typical installation time is 9–12 hours.

# TABLE OF CONTENTS

## INTRODUCTION

SAFETY INFORMATION .....	3
DOOR PARTS, MATERIALS & TOOLS LIST .....	4
FINAL DOOR ASSEMBLY .....	5

## GARAGE DOOR

STEP 1 - PREPARING THE OPENING .....	6
STEP 2 - PREPARE & PLACE FIRST (BOTTOM) SECTION .....	7-8
STEP 3 - PREPARE & PLACE SECOND & THIRD (MIDDLE) SECTIONS .....	9-10
STEP 4 - PREPARE & PLACE FOURTH (TOP) SECTION .....	11-13
STEP 5 - ASSEMBLE ROLLERS .....	14
STEP 6 - ASSEMBLE VERTICAL TRACK .....	15-16
STEP 7 - ASSEMBLE HORIZONTAL TRACK .....	17-19
STEP 8 - INSTALL LOCK .....	20

## EXTENSION SPRING

EXTENSION SPRING PARTS & TOOL LIST .....	21
STEP 9 - ASSEMBLE EXTENSION SPRINGS .....	22-25

## FINISH UP

STEP 10 - LIFTING YOUR DOOR FOR THE FIRST TIME .....	26
STEP 11 - ATTACHING OPENER .....	27
STEP 12 - PREPARE & INSTALL LIFT HANDLES .....	28

## APPENDIX

APPENDIX .....	29-34
Check Headroom, Backroom, Sideroom / Removing the Existing Door Springs / Removing Existing Door / Annual Maintenance and Cleaning	
TROUBLESHOOTING .....	35
WARRANTY .....	36

# ITEMS TO CONSIDER

- **TRACK AND HARDWARE:** Express warranties apply only to doors installed using original, factory-supplied sections, parts and hardware and in strict adherence with these instructions.

### **WARNING**

*Never reuse old track or hardware when installing a new door as it may cause installation problems or door to fall which could result in serious injury or property damage.*

- **AUTOMATIC DOOR OPENER:** Installation of a reinforced mounting point is required to avoid damage (Step 4-4).

- **DRILLING:** Take care not to drill through the outside steel skin unless otherwise instructed.
- **LOW HEADROOM:** Special instructions and additional hardware may be required. Before beginning, verify the headroom and options for door matching your application (Appendix A).
- **PAINTING THE DOOR:** If you plan to paint the door be sure to follow directions in Appendix D. We recommend painting the door and allowing it to dry completely before beginning installation.
- **HIGH WIND AREAS:** Doors installed in high windload regions may require additional reinforcement. Refer to Supplemental Instructions for details if applicable.

# IMPORTANT SAFETY INFORMATION



## WARNING

**TO PROTECT YOURSELF FROM INJURY, YOU MUST CAREFULLY READ THE FOLLOWING SAFETY INFORMATION AND WARNINGS BEFORE YOU INSTALL OR USE YOUR NEW GARAGE DOOR!**

### BEFORE INSTALLING YOUR DOOR

- You can install your new garage door yourself if:
  - a) you have help (it may weigh up to 150 lbs.)
  - b) you have the right tools and reasonable mechanical aptitude or experience
  - c) you follow these instructions very carefully
- Garage doors use springs to balance them. There are two types of springs – extension or torsion. Each of these is available in either a standard or EZ-SET® assembly option. Please look at the drawings in Appendix B.1–B.3 to see which springs your old door has. If your door has a different type of spring, consult the original manufacturer's instructions for removal.
- If your old door uses torsion springs, do not attempt to remove the door or the springs yourself. Have a qualified door repair service remove them. Attempting to remove a torsion spring assembly without proper training or tools may result in an uncontrolled release of spring force which can cause serious or fatal injury (Appendix B.1–B.3).
- In removing a garage door that has extension springs, follow the instructions carefully (Appendix B.2), including the use of C-clamps or locking pliers on both sides of the door in order to keep the door from moving once the springs are removed.
- Springs, cables and bottom fixtures are under strong spring tension. Do not attempt to loosen any fasteners on these components. You could suddenly release spring forces and risk severe injury.
- Doors equipped with automatic garage door openers can cause serious injury or death if not properly adjusted and operated. To ensure safety of these doors:
  - a) test the sensitivity of the garage door opener's safety reverse mechanism monthly
  - b) if your door has a pull-down rope, you must remove it
  - c) make sure the door remains unlocked
  - d) ensure door is properly reinforced
  - e) do not allow children to play with the controls
- DO NOT attempt to install the door during windy weather conditions. The door sections may be blown down causing serious injury or property damage.
- Manufacturer disclaims all liability for any installation that is not in compliance with these installation instructions or applicable state or county building codes.

### WHILE INSTALLING YOUR DOOR

- Use only the track specified and supplied with the door.
- Bolts must be installed at the rear end of horizontal tracks. These act to stop the rollers and keep the door from rolling off the back of the track.
- Track installations must use sway braces on the rear track hangers to prevent sideways movement. If the tracks are not firmly stabilized they might spread, allowing the door to fall and cause severe injury and damage.
- Do not attach any brackets directly to drywall or sheet rock. All track brackets, flag brackets and spring brackets should only be attached directly to 2" × 6" wood jambs. Otherwise, brackets could pull out of the drywall with dangerous force.

### AFTER INSTALLING YOUR DOOR

- The brackets at the bottom corners of your garage door are under great tension. Do not attempt to loosen any bracket fasteners except when and as directed in detail in the following instructions. Otherwise, the bracket could spring out with dangerous force.
- Do not permit children to play beneath or with any garage door or electronic operating controls.
- Keep hands and fingers clear of section joints, track and other door parts when the door is opening and closing to avoid injury. In particular, do not place fingers in section joints in order to close the door, as finger pinch, crush or amputation will result. The lift handles are located for safe operation as well as easy use.
- If the garage door and/or any of the supporting track are damaged, operating the door could be hazardous. Contact Clopay Consumer Services Department.
- If repairs are ever required to your door, safety and trouble-free operation can be best assured by using original replacement parts.
- Once you have completed the installation of your new garage door, please be sure that your garage complies with all applicable ventilation requirements before you enclose any vehicles in the garage. Good ventilation avoids fire and health hazards caused by fumes accumulating within a well-sealed garage.
- Only approved residential garage door openers are permitted to be used in residential applications. A residential application is a building for four families or less, or a garage that is serving the primary residence.
- Install operator control panel away from garage door track and the door itself. Keep body parts away from track at all times when operating an opener or opening/closing a garage door.



**In the interest of safety this symbol means WARNING or CAUTION. Personal injury and/or property damage may occur unless instructions are followed carefully.**

# DOOR PARTS, MATERIALS & TOOLS LIST\*

## PARTS INCLUDED

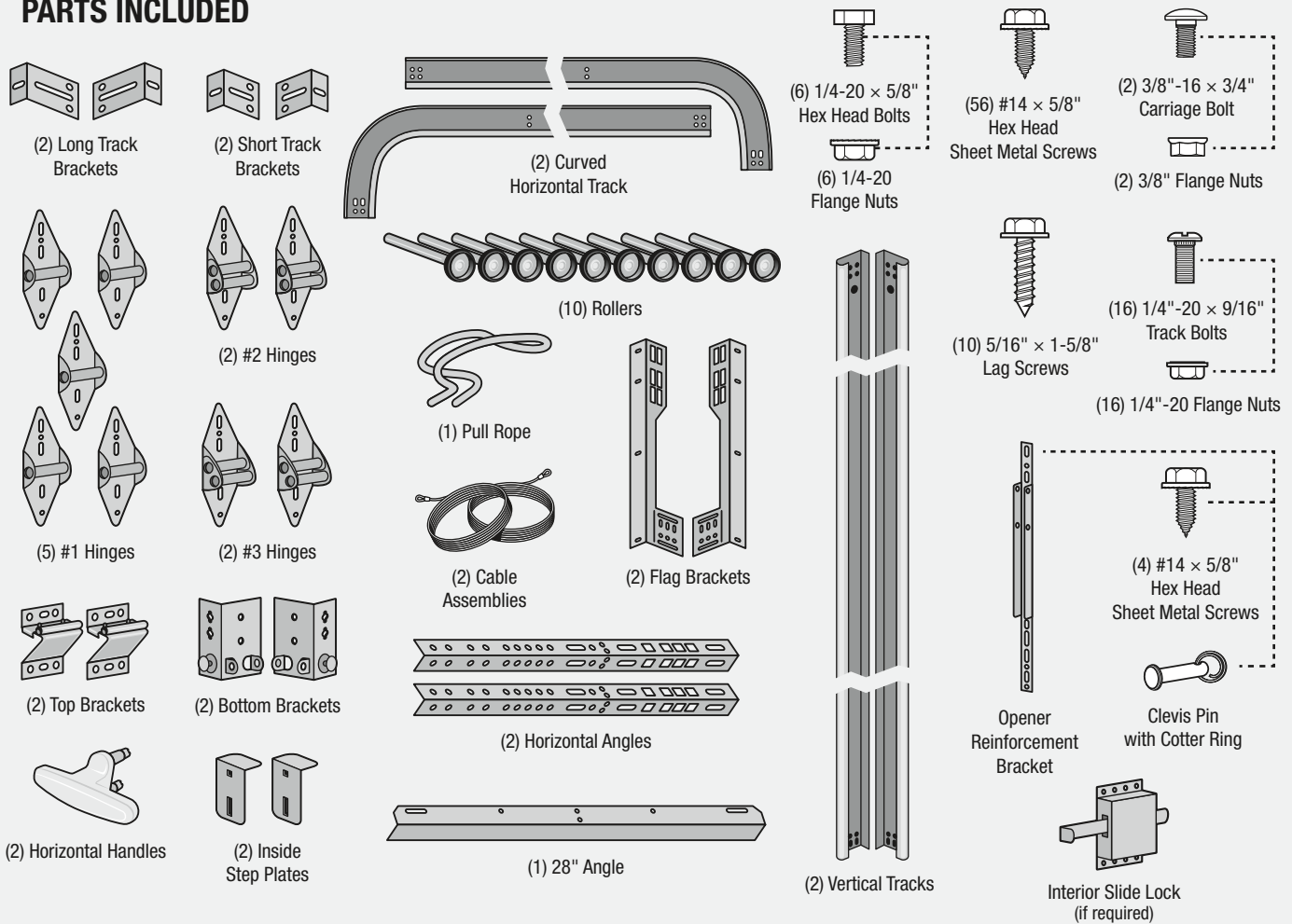

## MATERIALS NEEDED (NOT INCLUDED)

### GENERAL

- (1) Can of Clopay® Garage Door Pro Lube  
(In Store - SKU 531-434, Online - 202794367)
- (24) 10d 3" common nails
- Stop molding
- Wood shims
- Wood block
- Rope

### REAR TRACK HANGER SPECIFIC

- (1) Rear Track Hanger Kit  
(In Store - SKU 235-466, Online - 100078084)  
or
- 1-1/4" × 1-1/4" minimum 13 ga. (3/32") minimum thickness  
punched angle for rear track hangers (Step 7-4)
- (8) 3/8" × 1" bolts and nuts for rear track hangers
- (6) 5/16" × 1-1/2" lag screws for rear track hangers

## TOOLS NEEDED (NOT INCLUDED)

- |   |  |  |   |
|---|--|--|---|
| <input type="checkbox"/> Work Gloves                | <input type="checkbox"/> Socket Wrench Set   | <input type="checkbox"/> Stepladder  | <input type="checkbox"/> Angle Square   |
| <input type="checkbox"/> Safety Goggles             | <input type="checkbox"/> Level   | <input type="checkbox"/> Sawhorses (with non-<br>abrasive carpet or other soft<br>material on top surface) or<br>other supports for placing<br>section on while assembling | <input type="checkbox"/> Additional tools<br>may be required for<br>spring installation |
| <input type="checkbox"/> C-clamps or Locking Pliers | <input type="checkbox"/> 7/16" and 9/16"<br>Box Wrenches   | <input type="checkbox"/> Hacksaw   |   |
| <input type="checkbox"/> Hammer                     | <input type="checkbox"/> Drill, 1/4", 3/16", 3/8",<br>and 1/2" Drill Bits, 7/16"<br>and 9/16" Drive Bits |  |   |
| <input type="checkbox"/> Flathead Screwdriver       |  |  |   |
| <input type="checkbox"/> Measuring Tape             |  |  |   |

\* See page 21 for additional spring parts, materials and tools.

# FINAL DOOR ASSEMBLY

Drawing below is a generalized interior view of the door. Some models may vary.

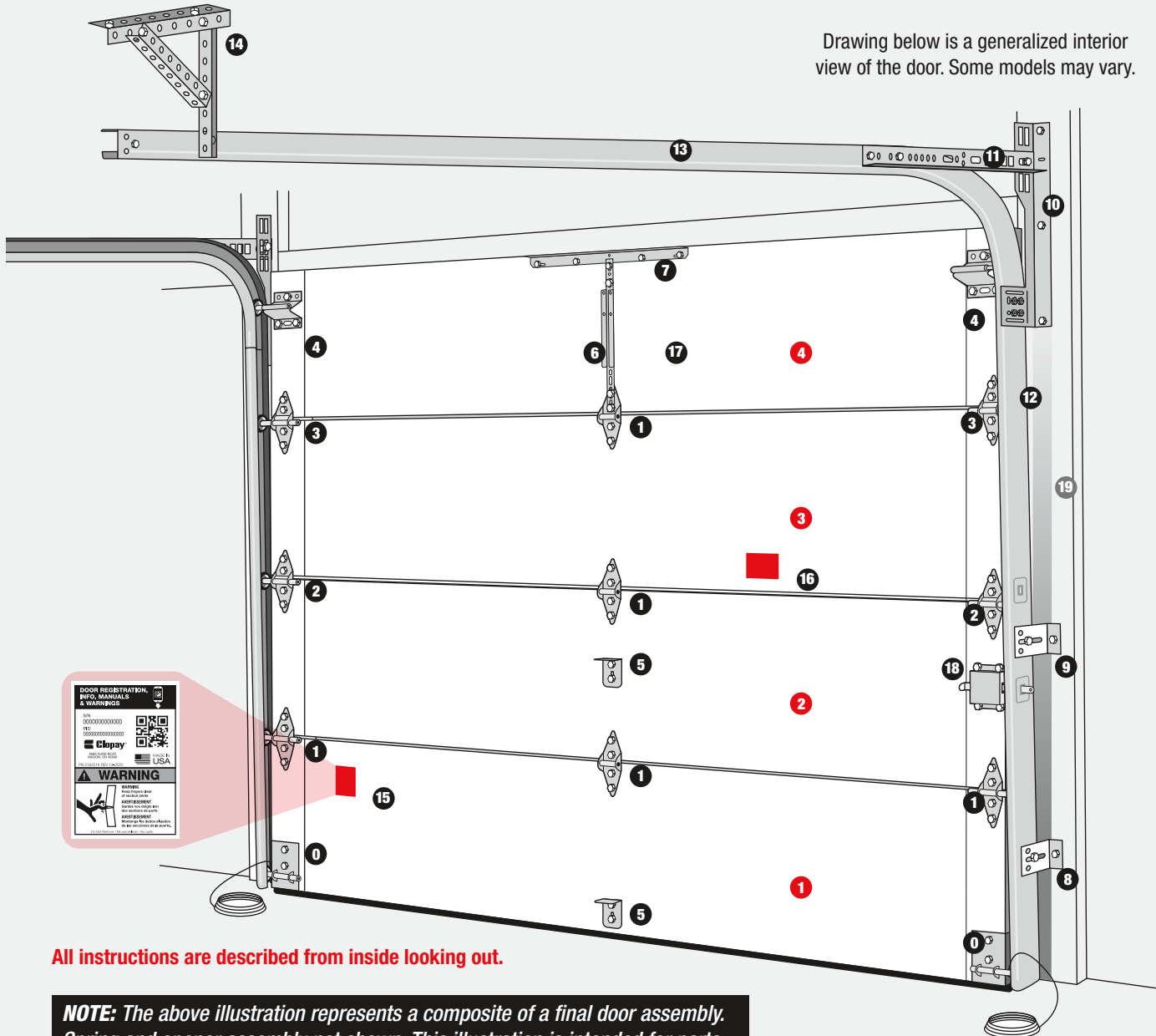

All instructions are described from inside looking out.

**NOTE:** The above illustration represents a composite of a final door assembly. Spring and opener assembly not shown. This illustration is intended for parts identification and reference only.

## ASSEMBLY COMPONENTS

- |                                |                                |                                     |                                      |
|--------------------------------|--------------------------------|-------------------------------------|--------------------------------------|
| 1 First (Bottom) Door Section  | 0 Bottom Bracket               | 8 Short Track Bracket               | 16 General Warning Label             |
| 2 Second (Middle) Door Section | 1 #1 Hinge                     | 9 Long Track Bracket                | 17 Opener Label                      |
| 3 Third (Middle) Door Section  | 2 #2 Hinge                     | 10 Flag Bracket                     | 18 Interior Slide Lock (if required) |
| 4 Fourth (Top) Door Section    | 3 #3 Hinge                     | 11 Horizontal Angle Bracket         | 19 Door Jamb (pre-existing 2" x 6")  |
|                                | 4 Top Bracket                  | 12 Vertical Track                   |                                      |
|                                | 5 Step Plate                   | 13 Curved Horizontal Track          |                                      |
|                                | 6 Opener Reinforcement Bracket | 14 Rear Track Hanger (not included) |                                      |
|                                | 7 28" Angle                    | 15 Serial Number Label              |                                      |

**NOTE:** If labels are obstructed or missing, contact Clopay Customer Service for replacement.

# 1 PREPARE THE OPENING

## MATERIALS NEEDED FOR THIS STEP

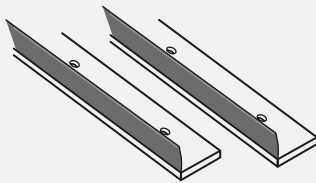

Optional Stop Molding and Finish Nails

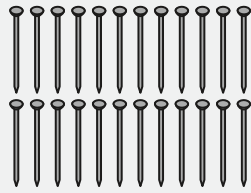

(24) 10d 3" Common Nails

## TOOLS NEEDED FOR THIS STEP



Safety Glasses

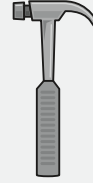

Hammer



Level

### Step 1-1 Framing

**NOTE:** Rough opening (framed opening without stop molding) = door size

- If an old door was removed, inspect jambs for rotted or damaged wood and replace immediately if found.
- Inside of door opening should be framed with 2" x 6" lumber.
- Vertical jamb should extend past opening to match headroom required (Appendix A).
- Jambs should be plumb and header should be level (Fig. 1-A).
- Be sure bolts fastening jambs to wall are flush.

Fig. 1-A

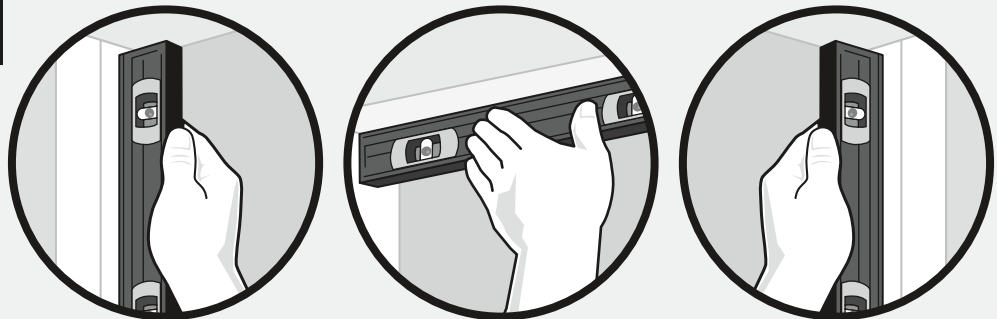

### Step 1-2 Stop Molding

- Door stop molding should be temporarily but securely nailed to edges of jambs and flush with inside framing (Fig. 1-B).

**NOTE:** Stop molding with built-in weatherseal is offered as an option.

**NOTE:** Refer to Appendix B through C for detailed instructions on old door teardown and door opening preparation.

Fig. 1-B

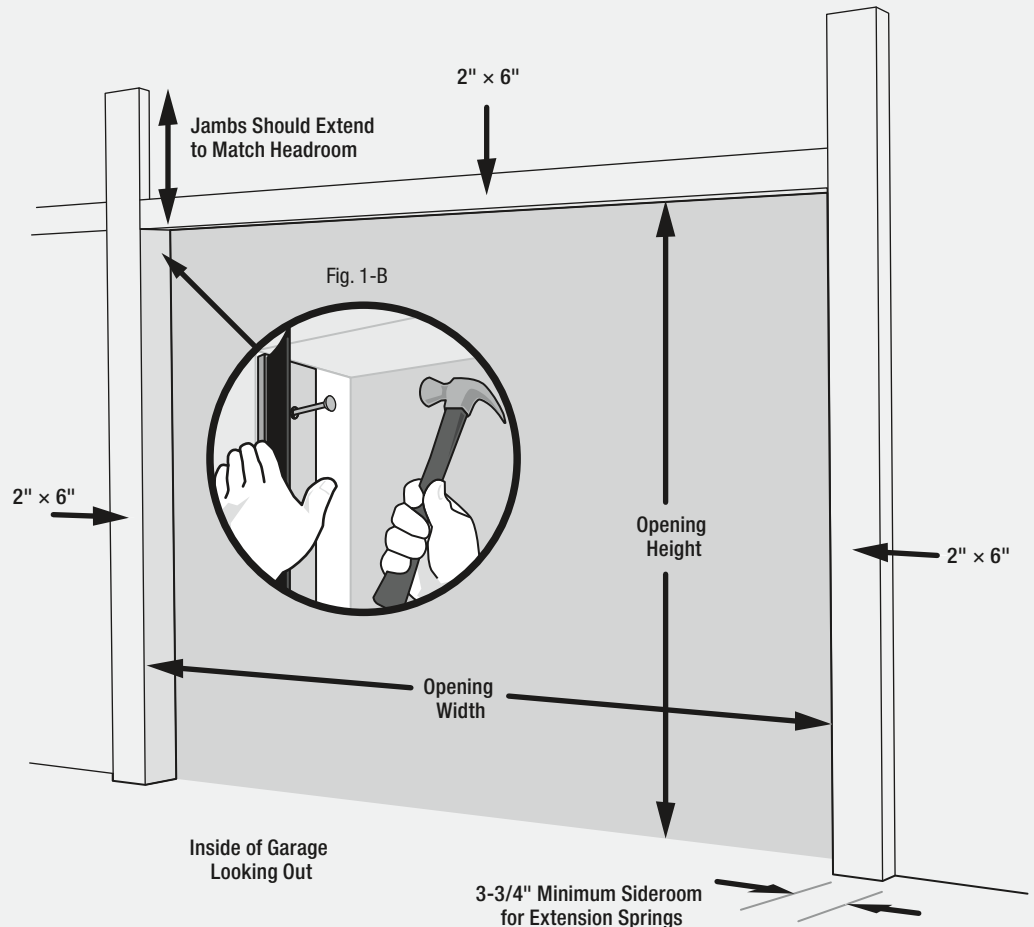

## PARTS NEEDED FOR THIS STEP

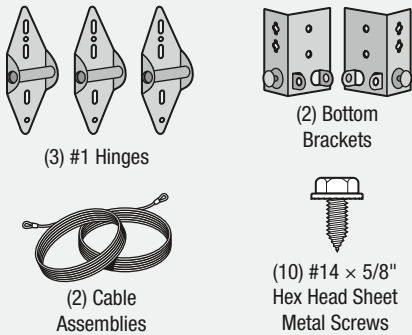

## MATERIALS NEEDED FOR THIS STEP



## TOOLS NEEDED FOR THIS STEP

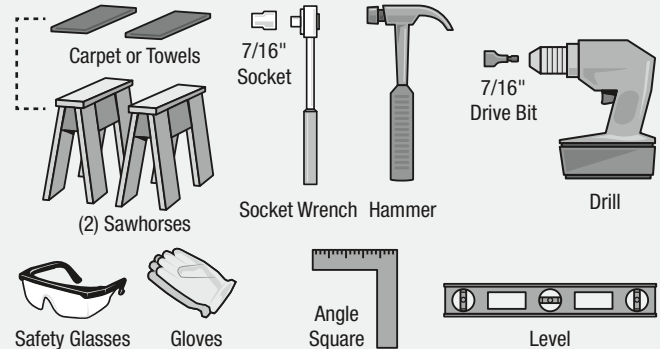

### Step 2-1 Locate Bottom Section

- Find section with aluminum weatherstrip retainer fastened to one edge. Retainer is on bottom edge of bottom section.
- Cover sawhorses with non-abrasive carpet or cloth so as not to scratch section.
- Place door section on sawhorses face down (Fig. 2-A).

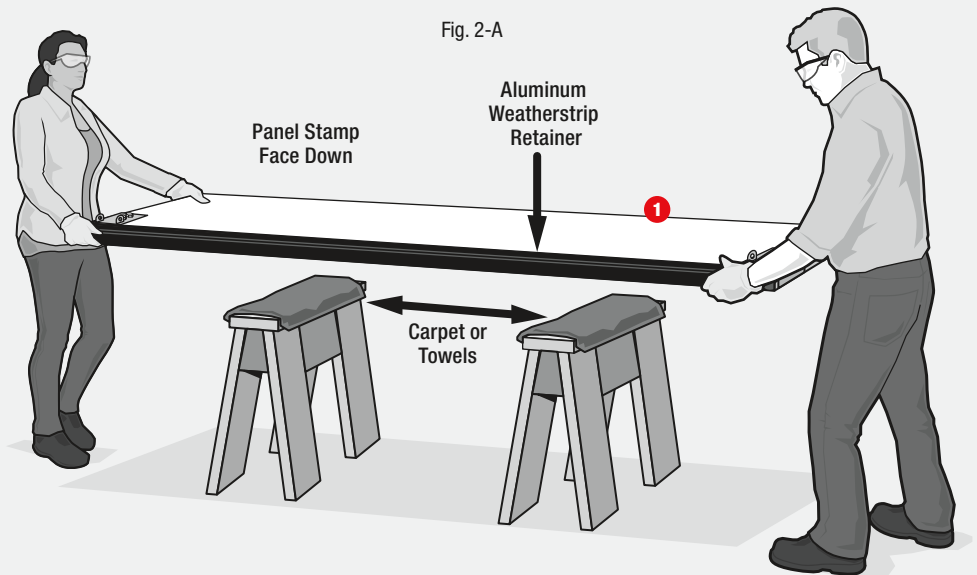

### Step 2-2 Prep Bottom Brackets

- By hand, bend to break apart bottom brackets (Fig. 2-B). Remove connecting tabs.

### Step 2-3 Attach Bottom Brackets

- Slide bottom brackets up to fully engage safety tabs into slots on stile (Fig. 2-C).
- Using (2) #14 × 5/8" sheet metal screws, attach bottom brackets to bottom corners of door section (Fig. 2-D).

#### ⚠ WARNING

*Failure to properly engage safety tabs on bottom bracket into slots on edge of door may cause sections to fall or spring to break free when spring tension is applied, which can result in severe injury.*

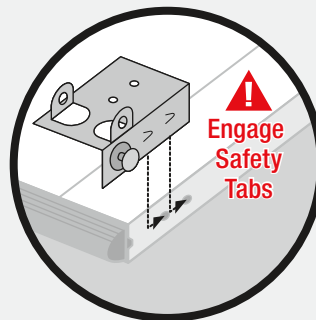
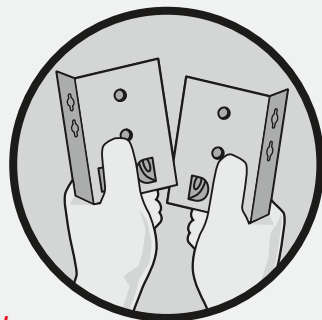

Repeat on Opposite Side

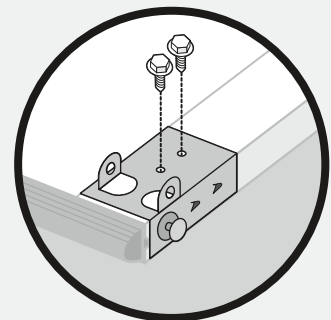

Repeat on Opposite Side

## Step 2-4 Add Hinges

- Hinges are pre-stamped with numbers 1, 2 and 3.
- Attach a number 1 hinge to each pair of pre-punched holes along top edge of section using (2) #14 × 5/8" sheet metal screws for each hinge (Fig. 2-E).

**NOTE:** Doors installed in high windload regions may require additional reinforcement beyond what is detailed in these instructions. Please refer to supplemental windload instructions if required in your area.

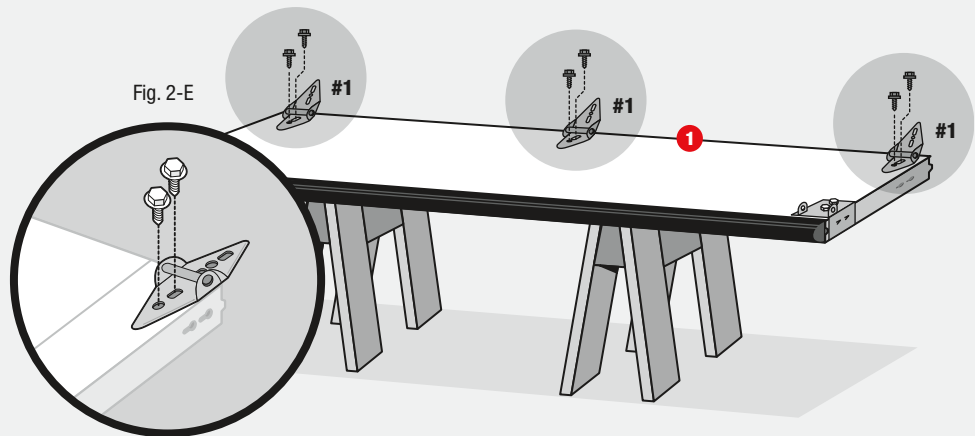

Repeat in Middle and on Opposite Side

## Step 2-5 Place and Secure First Section

- Place bottom section in opening against stop molding, center side-to-side.
- Place a level on section. Use a wood shim under one end (if necessary) to make section level (Fig. 2-F).

**IMPORTANT:** Step 2-5 is the most important step to ensure your door is level.

- Once section is level, remove level and drive a 10d 3" common nail at an angle into jambs at each end over section to hold it in place (Fig. 2-G).

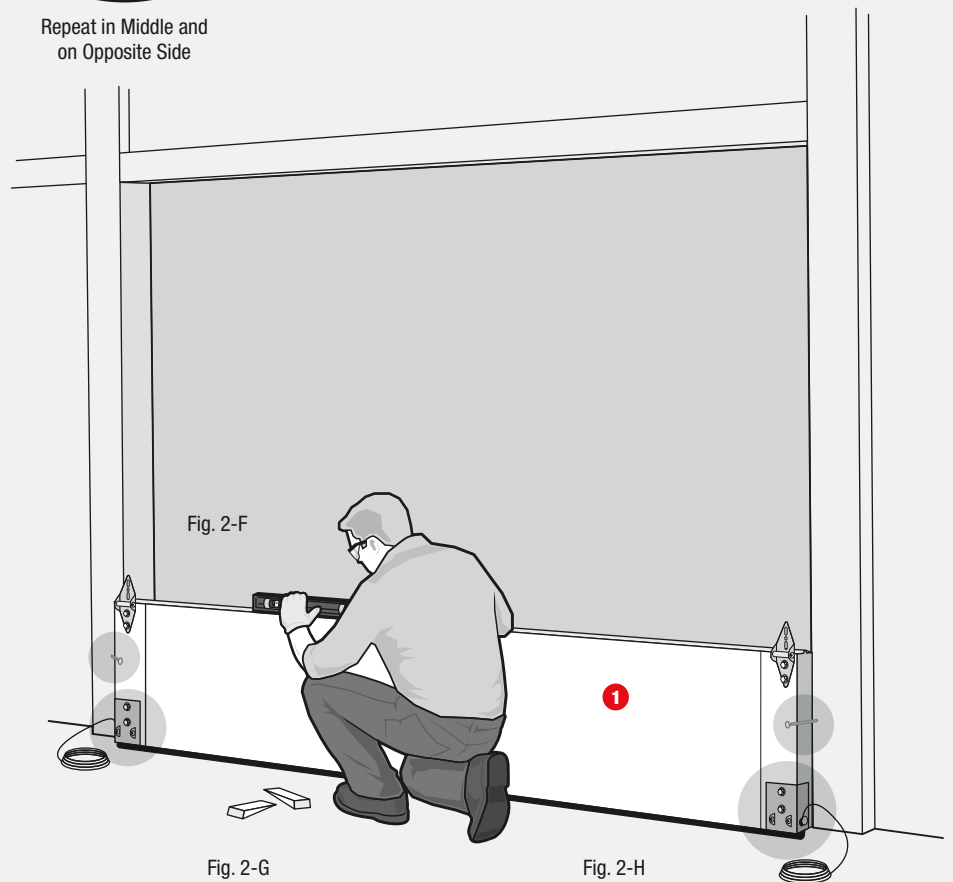
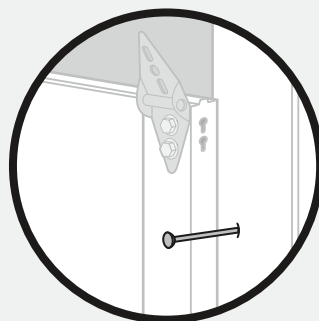

Fig. 2-G

Fig. 2-H

## Step 2-6 Attach Lift Cables

- Hook looped ends of steel lift cable over buttons on bottom brackets (Fig. 2-H).
- Coil remaining cable and place on floor for later assembly.



Repeat on Opposite Side

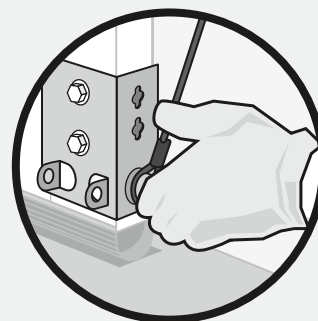

Repeat on Opposite Side

# 3

# PREPARE & PLACE SECOND (MIDDLE) SECTION

## PARTS NEEDED FOR THIS STEP

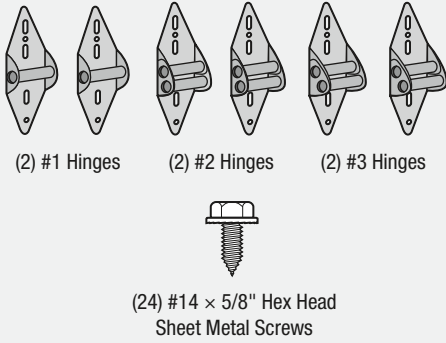

## MATERIALS NEEDED FOR THIS STEP

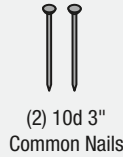

## TOOLS NEEDED FOR THIS STEP

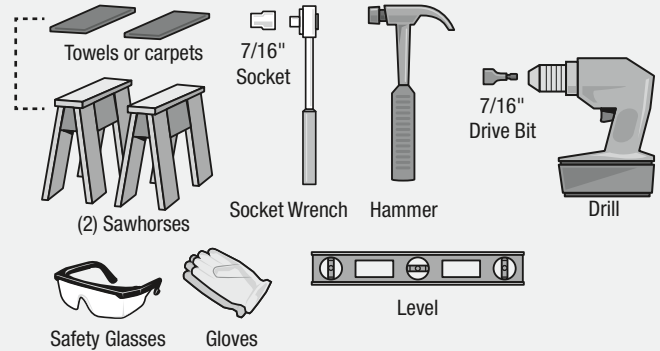

### Step 3-1 Prep Second Section

- Place section face down on covered sawhorses.
- Attach a #2 hinge to left and right outer top edges using (2) #14 × 5/8" sheet metal screws for each hinge. Attach a #1 hinge to pre-punched holes in center of top edge of section using (2) #14 × 5/8" sheet metal screws (Fig. 3-A).

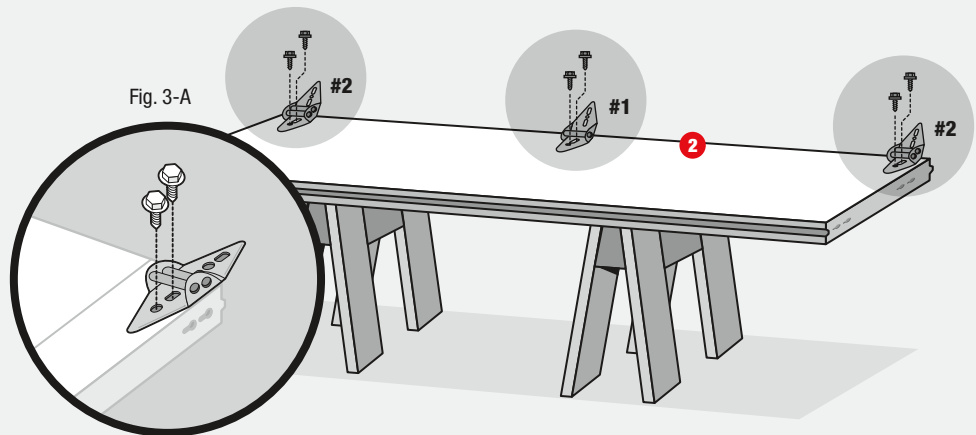

Repeat in Middle and on Opposite Side

### Step 3-2 Place and Secure Second Section

- Nest section on top of previously placed section and drive a 10d 3" common nail at an angle into jambs at each end over the section to hold it in place (Fig. 3-B).
- Attach all three hinges from top of previous section to bottom of section being placed using (2) #14 × 5/8" sheet metal screws for each hinge (Fig. 3-C).

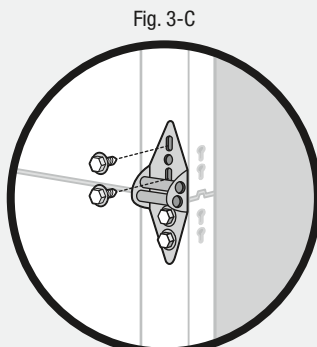
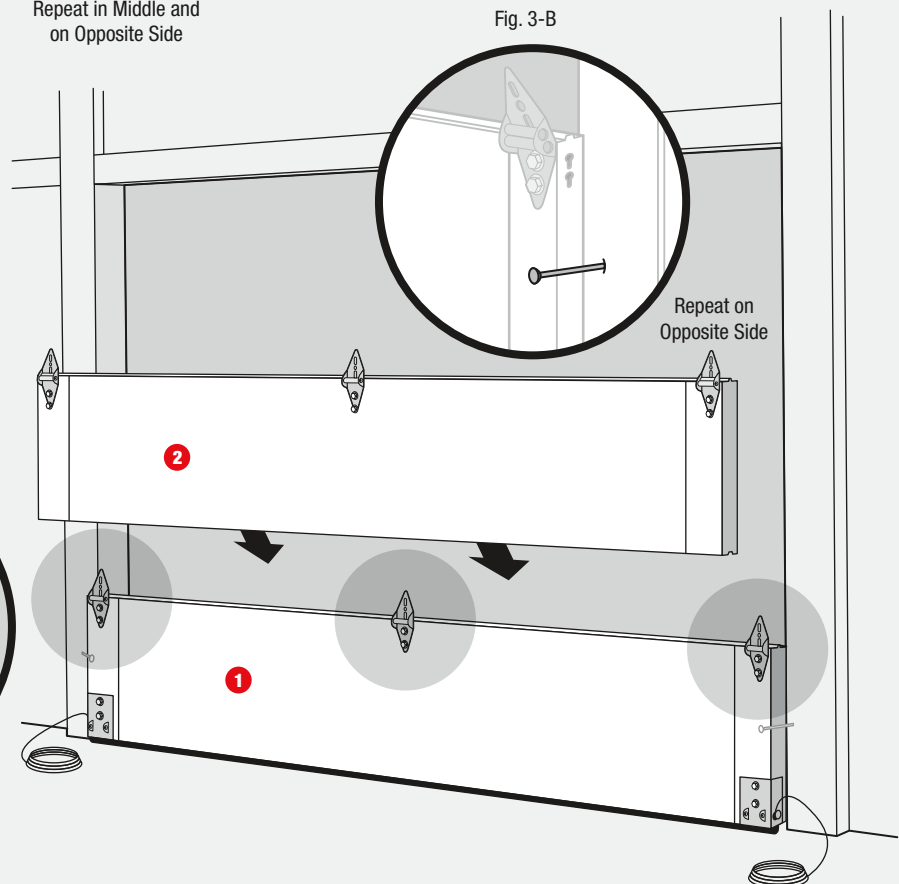

Repeat in Middle and on Opposite Side

## Step 3-3 Prep Third Section

**NOTE:** Some doors may come with a window section. If your door has a window section, it will be marked "Glass". There is no difference in installation of a glass section. Glass sections can be installed in the top section or third section position.

- Place section face down on covered sawhorses.
- Attach a #3 hinge to left and right outer top edges using (2) #14 × 5/8" sheet metal screws for each hinge. Attach a #1 hinge to pre-punched holes in center of top edge of section using (2) #14 × 5/8" sheet metal screws (Fig. 3-H).

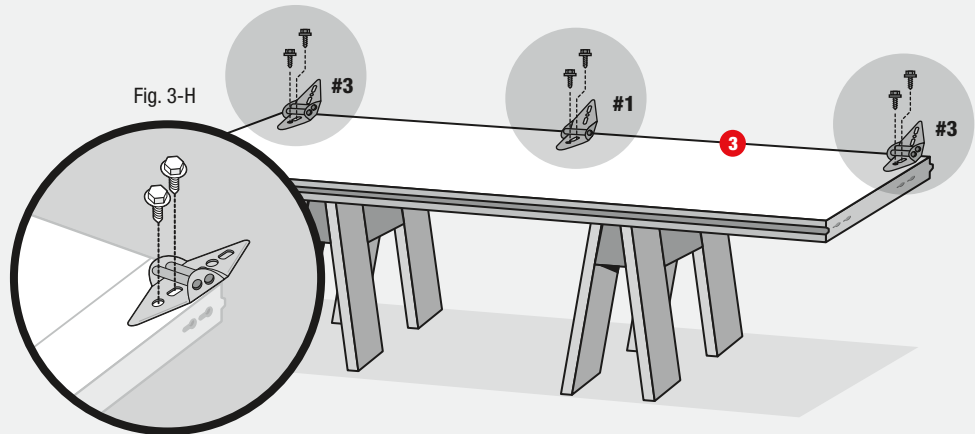

Repeat in Middle and on Opposite Side

## Step 3-4 Place and Secure Third Section

- Nest section on top of previously placed section and drive a 10d 3" common nail at an angle into jambs at each end over the section to hold it in place (Fig. 3-I).
- Attach all three hinges from top of previous section to bottom of section being placed using (2) #14 × 5/8" sheet metal screws for each hinge (Fig. 3-J).

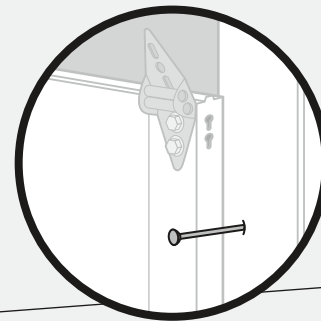

Repeat on Opposite Side

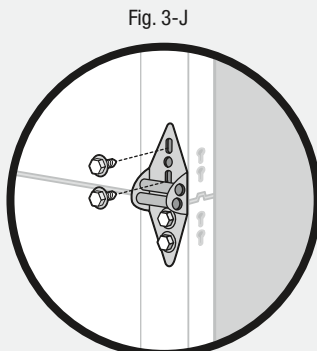

Repeat in Middle and on Opposite Side

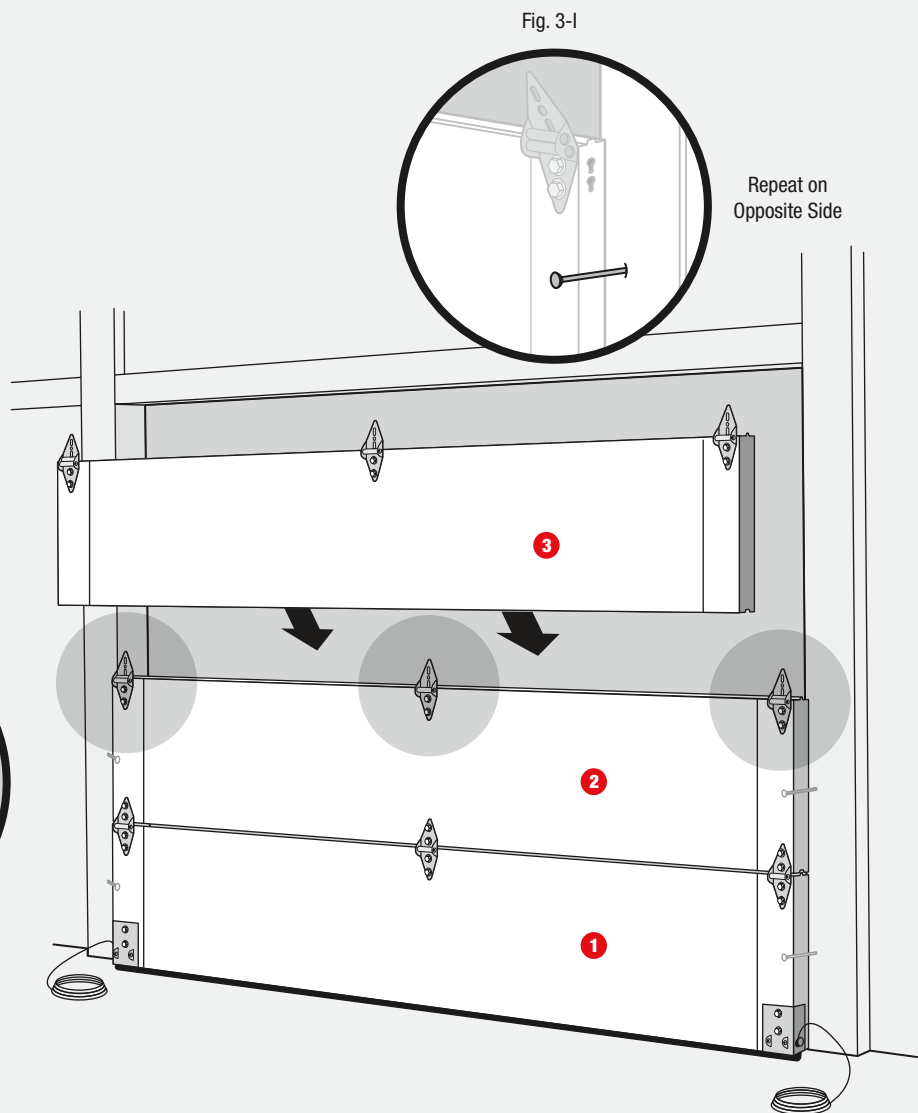

# 4

# PREPARE & PLACE FOURTH (TOP) SECTION

## PARTS NEEDED FOR THIS STEP

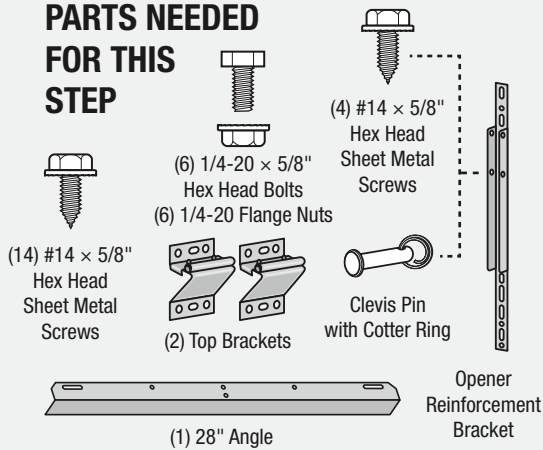

## MATERIALS NEEDED FOR THIS STEP

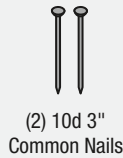

## TOOLS NEEDED FOR THIS STEP

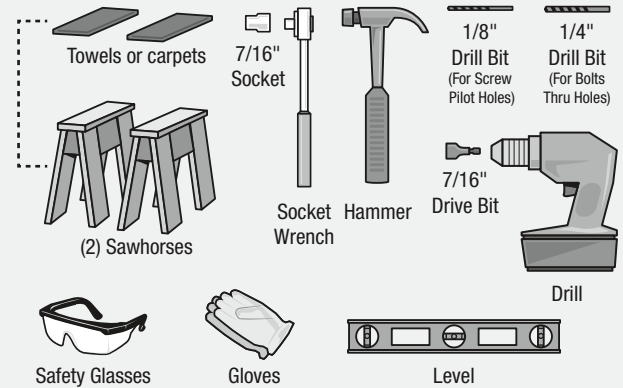

### Step 4-1 Attach Top Brackets

**NOTE:** Some doors may come with a window section. If your door has a window section, it will be marked "Glass". There is no difference in installation of a glass section. Glass sections can be installed in the top section or third section position.

- Place last section face down on covered sawhorses.
- Place top roller bracket 3-1/4" from top of section, aligning middle hole in top of bracket with bottom hinge hole/indentation (Fig. 4-A).
- Attach top bracket using (3) #14 x 5/8" sheet metal screws. Bottom part of bracket goes into two smaller holes/indentation (Fig. 4-A).

### CAUTION

Take care not to bend or twist sections with glass as this may cause glass to break, which may result in personal injury.

### Step 4-2 (HDS Only) Place 28" Angle

- Place angle centered along top of the door section.
- Use 1/8" drill bit to pre drill pilot holes for screws, holes to be centered.
- Using a drill or impact wrench with a 7/16" socket, drive (4) #14 x 5/8" sheet metal screws through bottom angle holes/slots as shown (Fig. 4-B). Do not attach angle at center hinge location at this time.

Fig. 4-A

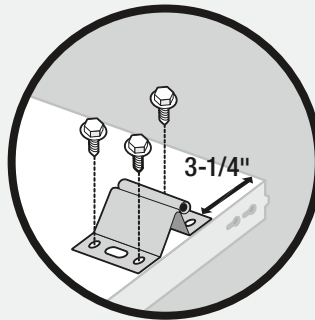

Repeat on Opposite Side

Fig. 4-B

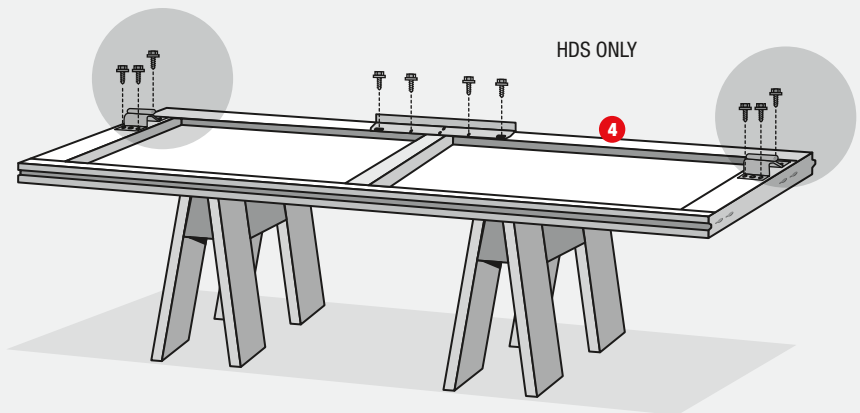
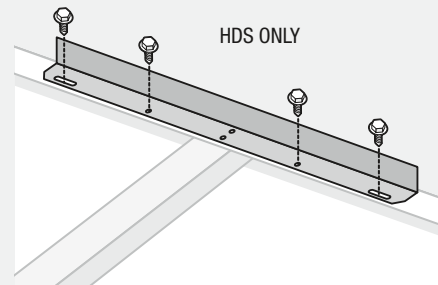

### WARNING

DO NOT install top section unless you are able to immediately continue through to Step 6 Assemble Vertical Track as this may cause sections to fall.

DO NOT install top section if there are high wind conditions as this may cause sections to fall. Failure to follow these warnings could result in serious injury, death or property damage.

# 4

# PREPARE & PLACE FOURTH (TOP) SECTION

## Step 4-2 (HDB, HDB with Lites, HDBL, 84A Only) Place 28" Angle

- Place angle centered along top of the door section.
- Use 1/4" drill bit to pre-drill thru holes for bolts and nuts, the holes need to be centered on return leg as shown.
- Place 1/4-20 x 5/8" hex head bolt into angle, through drilled hole in door skin and attach 1/4-20 flange nut. Tighten bolt and nut together using 7/16" socket and wrench as shown (Fig. 4-B). Repeat step for remaining bolts and nuts. Do not attach angle at center hinge location at this time.

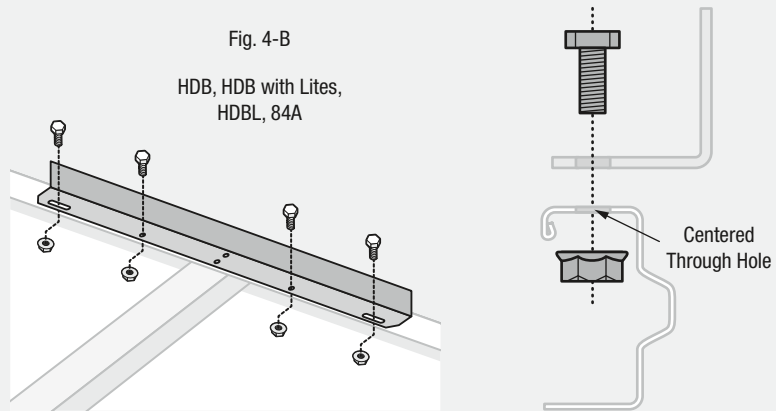

## Step 4-2 (75 WindCode® Only) Do Not Use 28" Angle

- Model 75 WindCode already has a top section rail strut therefore the 28" angle is not needed.

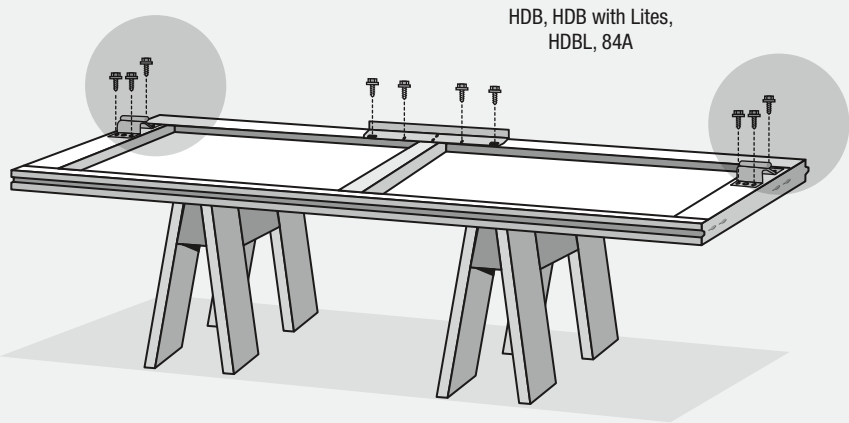

### ⚠ WARNING

**DO NOT install top section unless you are able to immediately continue through to Step 6 Assemble Vertical Track as this may cause sections to fall.**

**DO NOT install top section if there are high wind conditions as this may cause sections to fall. Failure to follow these warnings could result in serious injury, death or property damage.**

## Step 4-3 Place and Secure Top Section

- Nest top section on the other door section and drive a 10d 3" common nail at an angle into the jambs at each end over section to hold it in place (Fig. 4-C).
- Attach hinges on each edge from top of previous section to bottom of this section using (2) #14 x 5/8" sheet metal screws (Fig. 4-D).

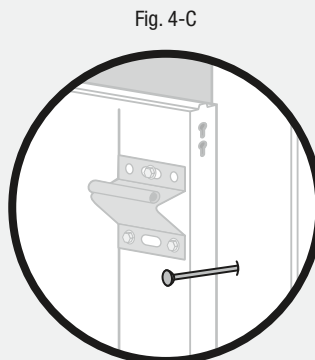

Repeat on Opposite Side

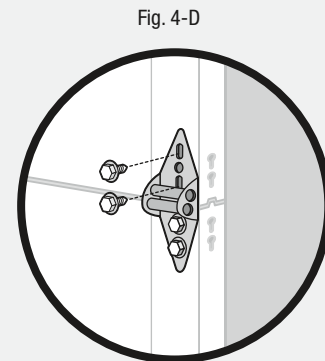

Repeat in Middle and on Opposite Side

**IMPORTANT: Do not attach center hinge at this time.**

# 4

## PREPARE & PLACE FOURTH (TOP) SECTION

### Step 4-4 Attach Opener Reinforcement Bracket

- Place opener bracket over the middle of the angle and directly over the center hinge (Fig. 4-E).
- Begin attaching the opener bracket by using (2) #14 × 5/8 sheet metal screws at the hinge location (Fig. 4-F).
- Finally, place the opener bracket over the 28" angle and attach using (2) #14 × 5/8 sheet metal screws (Fig. 4-G). On Model 75, place the opener bracket over rail strut and attach using (2) #14 × 5/8 sheet metal screws

### **⚠ WARNING**

*DO NOT install top section unless you are able to immediately continue through to Step 6 Assemble Vertical Track as this may cause sections to fall.*

*DO NOT install top section if there are high wind conditions as this may cause sections to fall. Failure to follow these warnings could result in serious injury, death or property damage.*

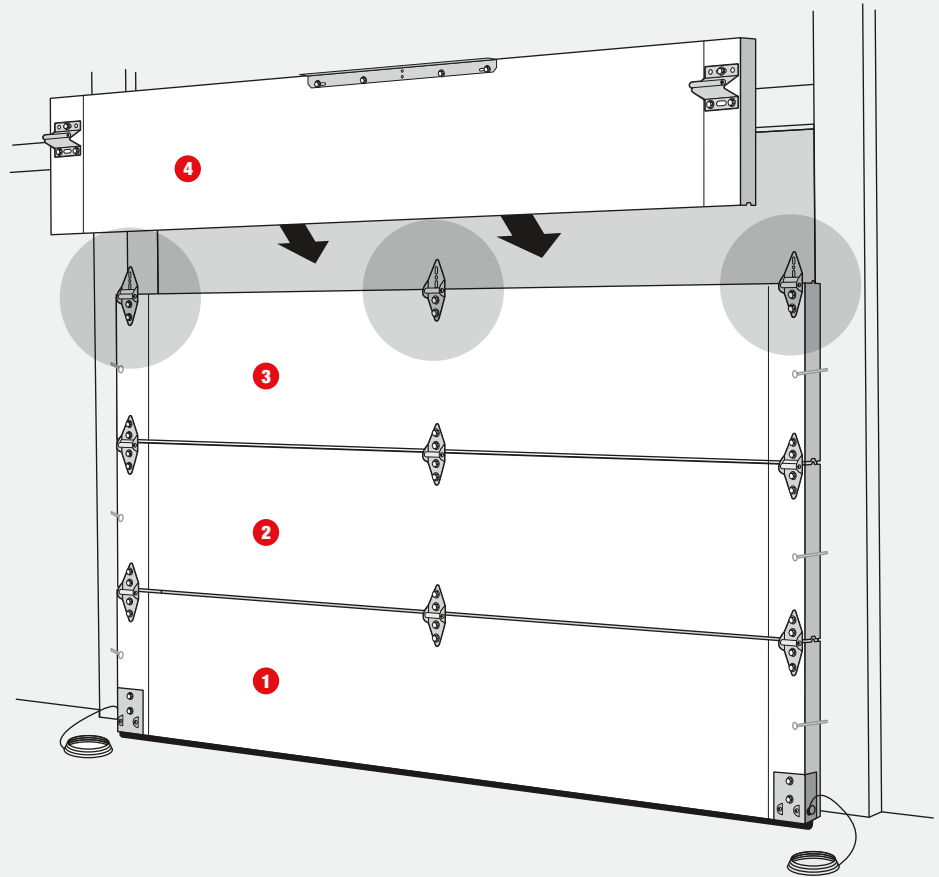

Fig. 4-E

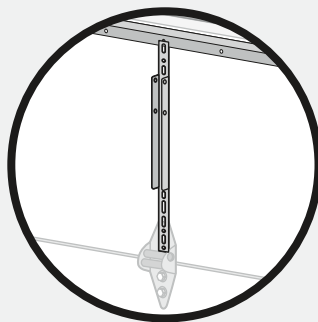

Fig. 4-F

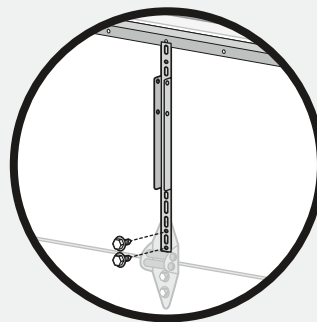
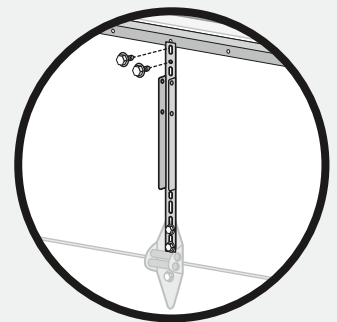

Fig. 4-G



# 5

# ASSEMBLE ROLLERS

## PARTS NEEDED FOR THIS STEP



## TOOLS NEEDED FOR THIS STEP



### Step 5-1 Place Rollers

- Place a roller in each top and bottom bracket, and in tubes of hinges at each edge of door (Fig 5-A).

**NOTE:** In hinges with two tubes, place roller in tube farthest from the face of door.

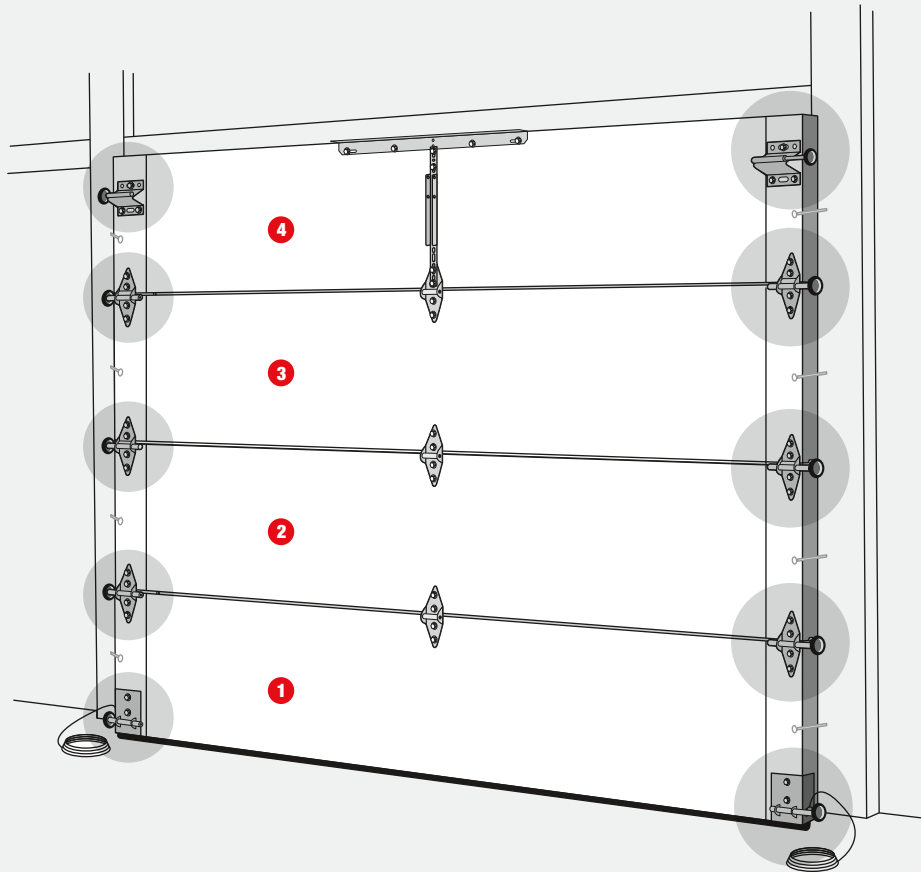
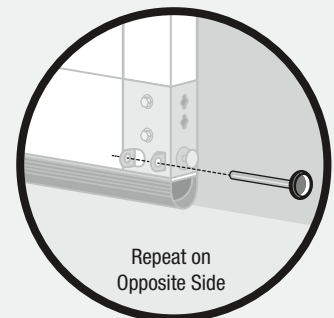
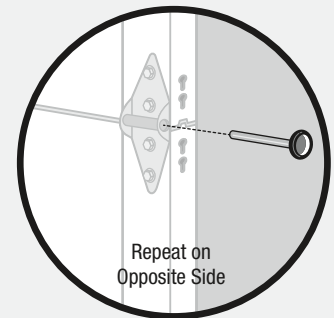
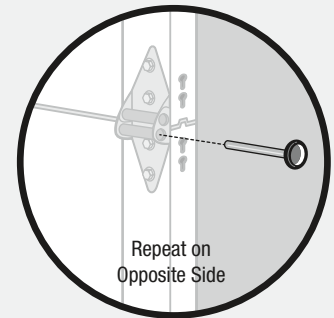
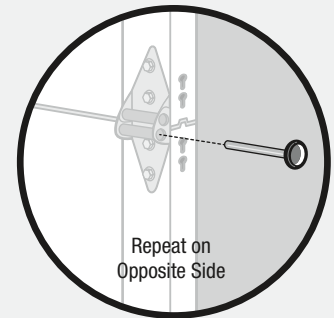
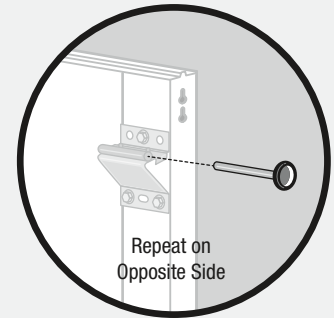

Fig. 5-A



# 6

# ASSEMBLE VERTICAL TRACK

## PARTS NEEDED FOR THIS STEP

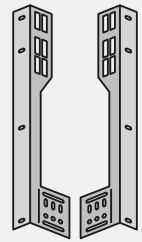

(2) Flag Brackets

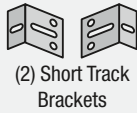

(2) Short Track Brackets

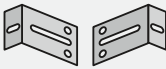

(2) Long Track Brackets



(2) Vertical Tracks

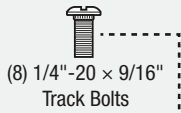

(8) 1/4"-20 x 9/16" Track Bolts



(8) 1/4"-20 Flange Nuts



(10) 5/16" x 1-5/8" Lag Screws

## TOOLS NEEDED FOR THIS STEP



Gloves



Safety Glasses



7/16" Socket



Socket Wrench



Flathead Screwdriver



3/16" Drill Bit



7/16" Drive Bit



Drill

### ⚠ WARNING

*Failure to use only track provided with new door may cause installation problems or the door to fall which could result in serious injury or property damage.*

### Step 6-1 Prep Each Track - Add Flag Brackets

- Align top two holes on each track with two inner holes on bottom of flag brackets and loosely attach using (2) 1/4"-20 x 9/16" track bolts and 1/4" flange nuts. The head of the bolts should face the inside of the track (Fig. 6-A).

Fig. 6-A

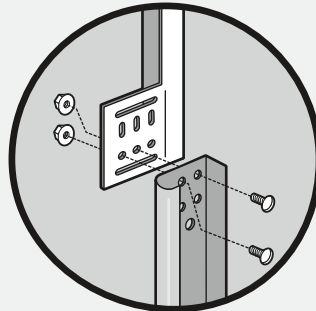

Repeat on Opposite Side

### Step 6-2 Prep Each Track - Add Track Brackets

- Using the horizontal slot in each track bracket, loosely fasten each track bracket to each vertical track using (1) 1/4"-20 x 9/16" track bolt and 1/4" flange nut with head of bolt facing to the inside of each track.
- The next larger sized pair of brackets should be installed centered on each track in between knockouts (Fig. 6-B).
- The shortest pair of track brackets should be installed 10" from bottom of each track with flange facing the flat side of the track (Fig. 6-C).
- Open side of track faces inward toward door opening.

Fig. 6-B

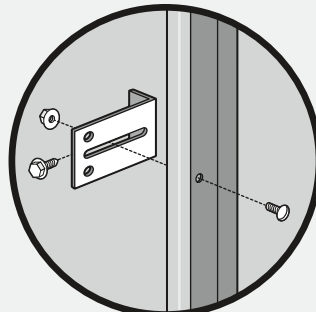

Repeat on Opposite Side

Fig. 6-C

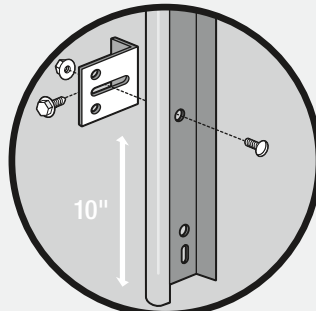

Repeat on Opposite Side

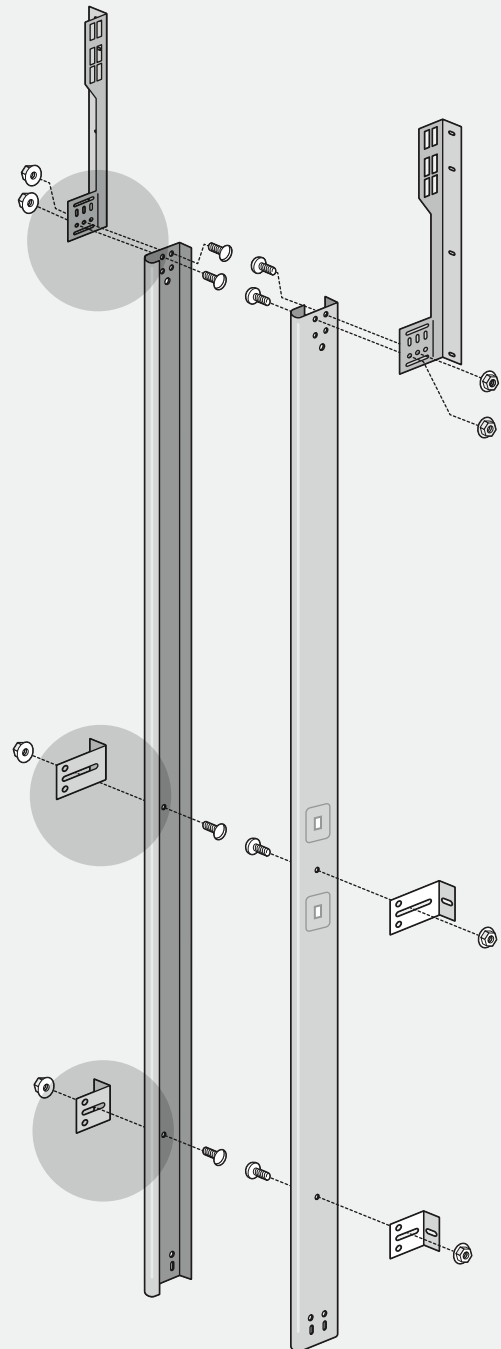

**NOTE:** If additional adjustment is required, horizontal slots in flag brackets can be used for attachment to vertical track.

# 6

# ASSEMBLE VERTICAL TRACK

## Step 6-3 Place Track into Position

**NOTE:** Complete steps shown in Figures 6-E through 6-J before starting the opposite side.

- Place track over rollers on door (Fig. 6-E).
- Move track close to door so that rollers are all the way into hinges, leaving about 1/2" between edge of door and track. Do not force track too tightly or door will bind (Fig. 6-F).
- Lift track 1/2" from floor and mark jamb for each lag screw (Fig. 6-G). Vertical track should not be raised beyond rollers on bottom section of door.

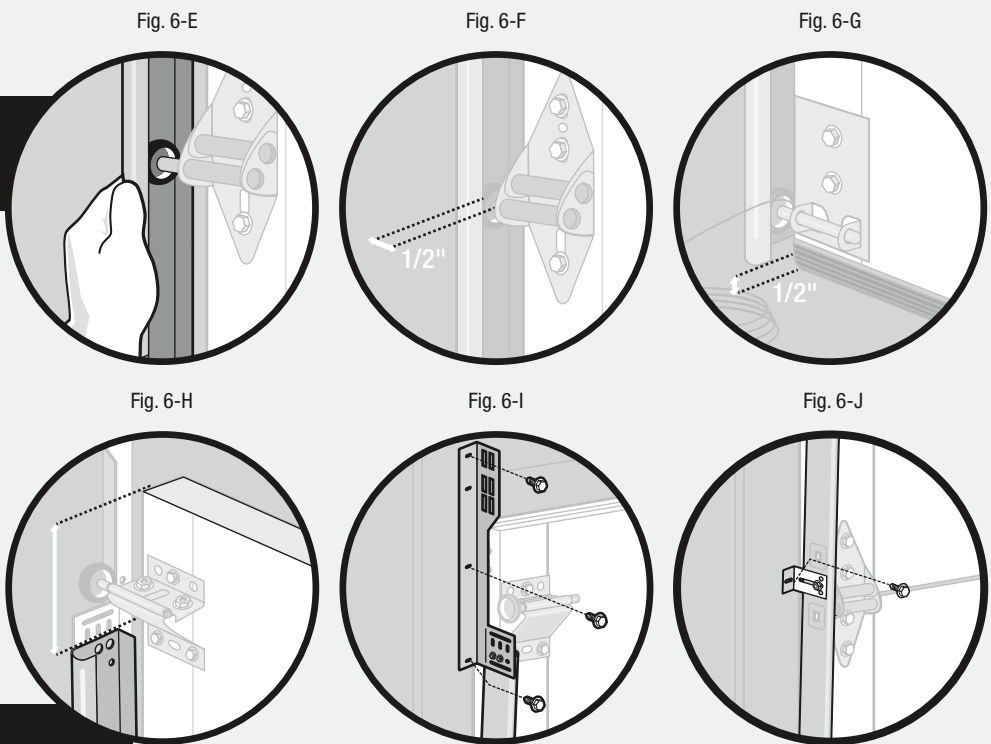

**IMPORTANT:** Tops of vertical tracks must be level with each other. Check this by measuring from top of door section to top of track on both sides. If they are not equal, cut some material off bottom of one track (no more than 1") to lower it, or raise other track (Fig. 6-H).

- Drill 3/16" pilot holes at each lag screw location on jamb. Then fasten flag bracket into jamb using (3) 5/16" × 1-5/8" lag screws, one each in top, middle and bottom holes. Do this for both sides of door (Fig. 6-I).
- Now fasten track brackets to jamb using (1) 5/16" × 1-5/8" lag screw in each bracket. Do this for both sides of door (Fig. 6-J).
- When track brackets and flag brackets are securely fastened to jamb, tighten track bolts and flange nuts connecting flag brackets to tracks.

### **⚠ WARNING**

**DO NOT attach any brackets directly to drywall. All track brackets and flag brackets should be attached directly onto wood door jamb. Failure to do so may cause track to detach from wall and fall which could result in property damage or serious injury.**

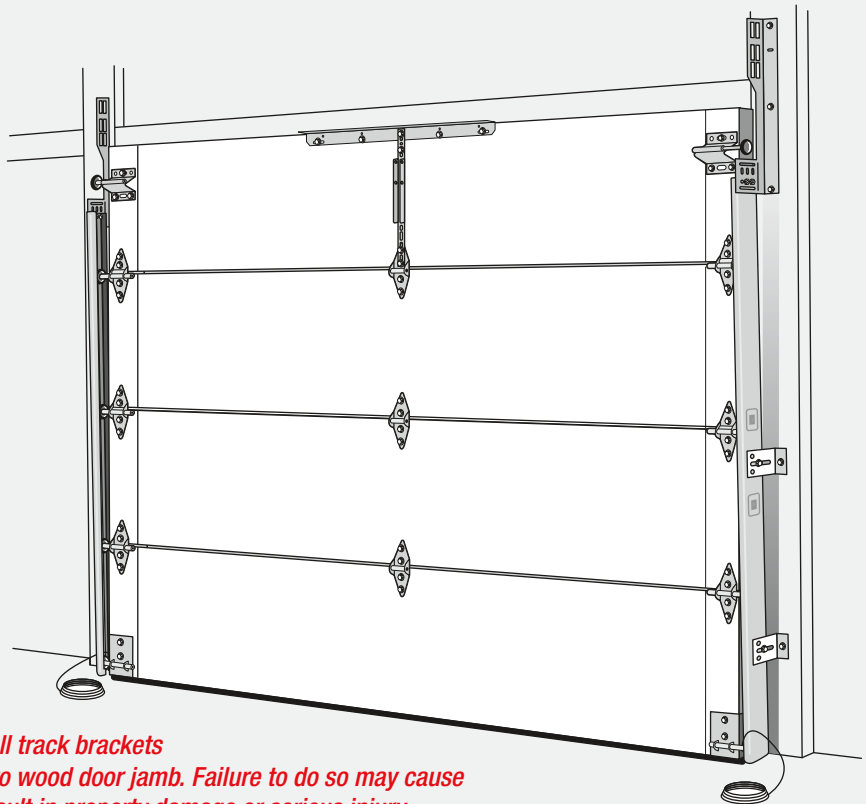

**NOTE:** Pressure-treated lumber purchased after January 2004 is treated with chemicals that have highly corrosive effects on metal fasteners. The fasteners provided with your door are intended for use with standard lumber only. If you are installing your door into an opening framed with pressure-treated lumber, it is highly recommended that 5/16" × 1-5/8" lag screws with a minimum galvanization equivalent of G185 be purchased for this application.

## PARTS NEEDED FOR THIS STEP

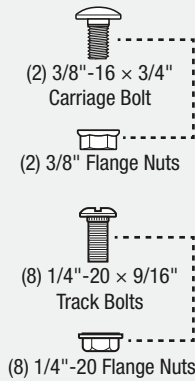
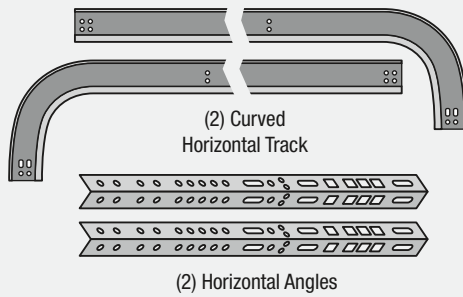

## TOOLS NEEDED FOR THIS STEP

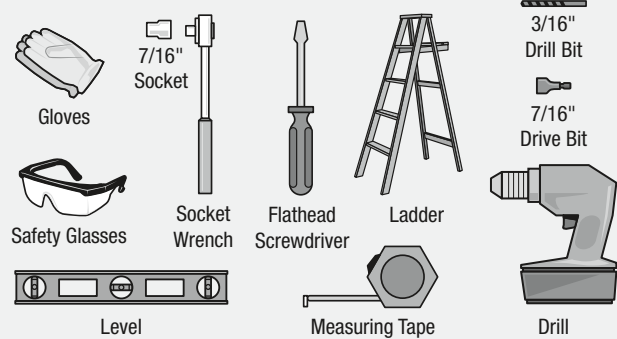

## MATERIALS NEEDED FOR THIS STEP (not included)

- (1) Rear Track Hanger Kit (SKU 235-466, Online - 100078084)
- 1-1/4" × 1-1/4" minimum 13 ga. (3/32") minimum thickness punched angle (Step 7-4)
- (8) 3/8" × 1" bolts and nuts
- (6) 5/16" × 1-1/2" lag screws
- Rope

**⚠ WARNING**

*Failure to use only track provided with new door may cause installation problems or door to come off of tracks and fall which could result in serious injury or property damage.*

**Step 7-1 Fasten Horizontal Angle to Horizontal Track**

- Fasten horizontal angle to horizontal (curved) track using (2) 1/4"-20 × 9/16" track bolts and 1/4" flange nuts with head of bolt facing the inside of each track (Fig. 7-A).

Fig. 7-A

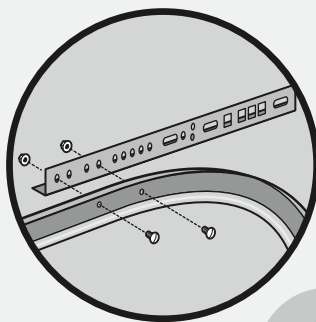

Fig. 7-B

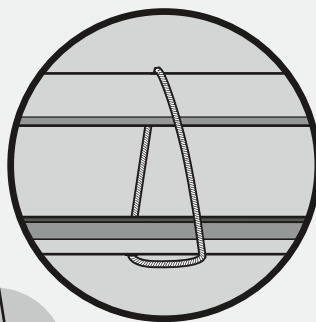

Fig. 7-C

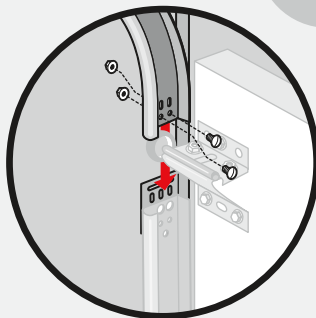
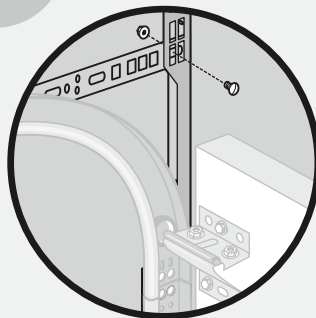

Fig. 7-D

**Step 7-2 Support Rear End of Track**

- Temporarily support rear end of track with a rope attached to overhead trusses or rest the track on a tall ladder (Fig. 7-B).

**Step 7-3 Attach Horizontal Track Assembly to Flag Bracket**

- Place curved end of horizontal track over roller in top bracket and align with vertical track.
- Attach horizontal track portion to flag bracket using (2) 1/4"-20 × 9/16" track bolts and 1/4" flange nuts with head of bolt facing the inside of each track (Fig. 7-C).

**NOTE:** Horizontal and vertical track must join together to form a continuous channel for rollers.

- Attach end of horizontal angle to top of flag bracket using a 3/8"-16 × 3/4" carriage bolt and a 3/8" hex nut. Bolt will be removed and replaced later during spring installation (Fig. 7-D).

### Step 7-4 Assemble Rear Track Hangers

**NOTE:** Rear track hangers are not provided with standard hardware. Use Rear Track Hanger Kit (SKU 425-1088), or make your own (Figures 7-E through 7-F). These are used to attach rear horizontal track to ceiling joist or support and must be strong enough to hold the full weight of door.

- Use 1-1/4" × 1-1/4" punched angle, at least 13 ga. or 3/32" steel to make two rear track hangers including sway braces. (Fig 7-E).
- Assemble rear track hanger using (3) 3/8" × 1" bolts (Fig. 7-F).
- Attach rear track hanger assembly to horizontal track using a 3/8" × 1" bolt. Bolt should be inserted pointing to the inside of the horizontal track allowing the bolt to stop the door at the end of its travel and prevent it from exiting the track. Sway brace must be perpendicular to the track (Fig. 7-G).

### Step 7-5 Position and Secure Horizontal Track

- Position of horizontal track is critical for door to operate properly. Horizontal track should be level and square to the door.
- Squareness should be measured by comparing two diagonal distances:
  - a) Distance from the top left-hand corner of the door to the rear of the opposite right-hand horizontal track.
  - b) Distance from the top right-hand corner of door to the opposite rear of the left-hand horizontal track (Fig. 7-H).

**NOTE:** To avoid inhibiting door travel, rear track hangers should not be mounted any farther in than 6" from the end of horizontal track.

- With track level and square with opening, track hangers can be fastened permanently to ceiling trusses or support. Drill 3/16" pilot holes before installing 5/16" × 1-1/2" lag screws.

### ⚠ WARNING

To prevent door from falling and causing serious injury, be sure rear track hangers are properly secured. Sway braces must be used to prevent tracks from spreading and adequate length screws must be used to fasten hangers into trusses.

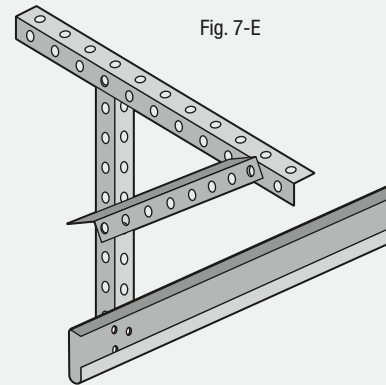

Fig. 7-E

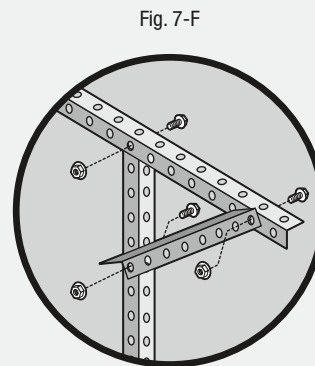

Fig. 7-F

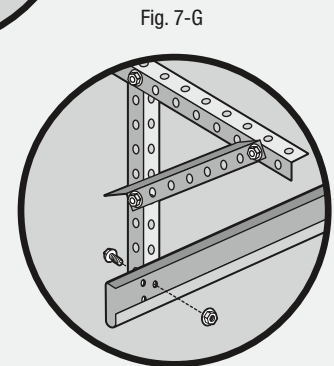

Fig. 7-G

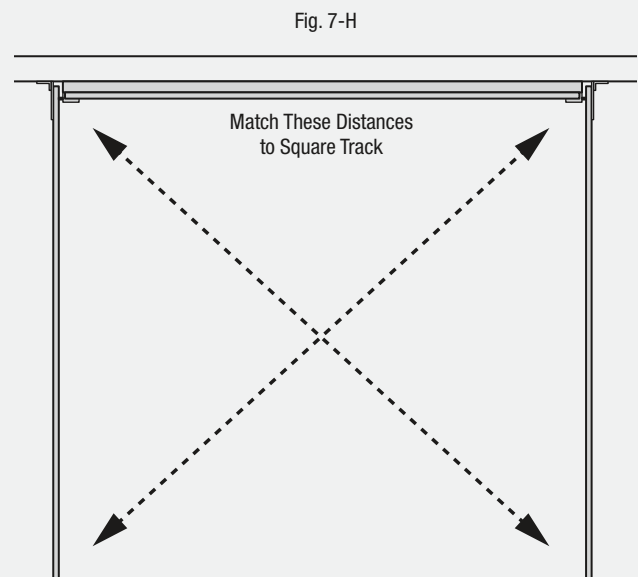

Fig. 7-H

**Step 7-6 Adjust Top Roller Bracket**

- With track installed, top door section can now be properly adjusted.
- If there is a gap between door and door jamb or stop molding, remove gap by loosening slide bolts on top roller bracket and push top of door toward stop molding or door jamb. While holding door against jamb pull roller toward you so it is tight against groove in track and tighten slide bolts (Fig. 7-I).

**NOTE:** Take care not to press door too tightly against door jamb or stop molding. It is normal to have a gap of up to 1/2" between the door and the jamb.

- Remove all the 10d 3" common nails that were used to hold sections in place (Fig. 7-J).

**Step 7-7 Install Pull Rope**

- Install the pull rope by attaching to roller shaft in bottom bracket of door (Fig. 7-K).

**NOTE:** Rope is intended only for use on manually operated doors.

Fig. 7-I

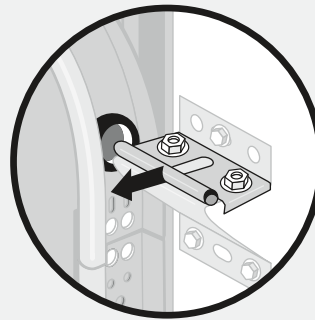

Fig. 7-J

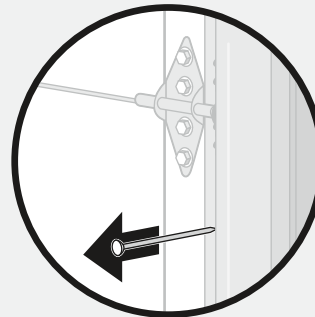
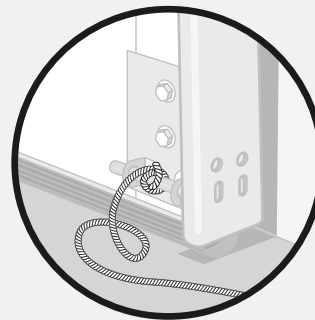

Fig. 7-K



# 8

# INSTALL LOCK (IF REQUIRED)

## MATERIALS NEEDED FOR THIS STEP

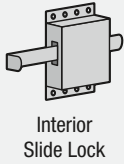

## TOOLS NEEDED FOR THIS STEP

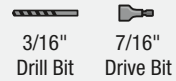
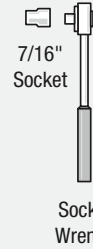

### Step 8-1 Install Interior Slide Lock

#### ⚠ WARNING

*If door is going to be equipped with an automatic garage door opener, disable or remove this lock. This will avoid damage to door.*

If a lock is included with door, follow appropriate instructions below.

- Use vertical track as a guide to achieve proper alignment.
- On second door section, position interior slide bolt against top of one of rectangular engaging slots in vertical track (Fig. 8-A).

**NOTE:** *It may be necessary to knock out slug in vertical track to open slot for lock engagement. Remove slug by striking with a hammer from outside of track.*

- On second door section end stile, install interior slide bolt. Use (4) #14 × 5/8" hex head sheet metal screws (steel doors) (Fig. 8-B).

**NOTE:** *3/16" holes may need predrilled before installing screws.*

### Step 8-2 Check Interior Slide Lock

- Once slide lock is in position, check for proper alignment of slide bolt to the engaging slot of vertical track (Fig. 8-C).

Fig. 8-A

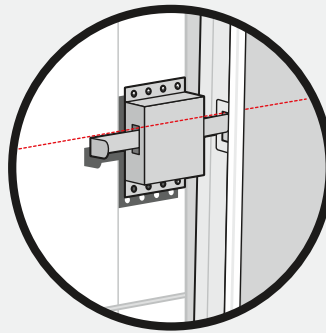

Fig. 8-B

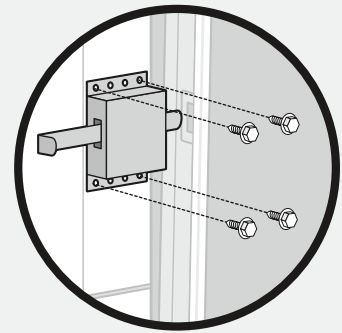
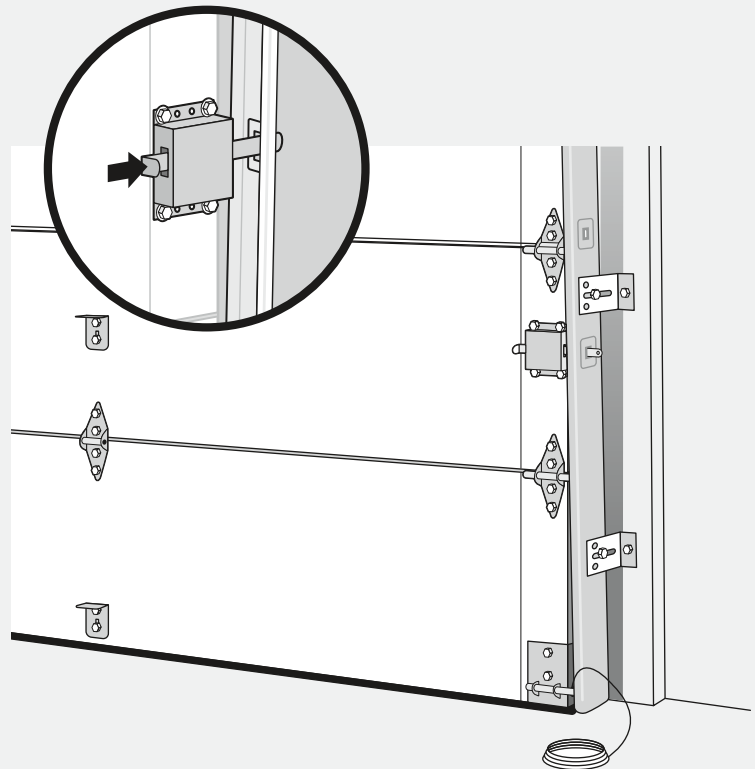

Fig. 8-C



# EXTENSION SPRING PARTS & TOOL LIST



## PARTS INCLUDED

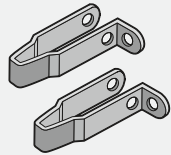

(2) Sheave Forks

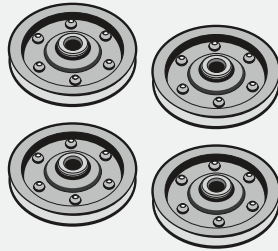

(4) Sheaves



(2) Safety Containment Cables

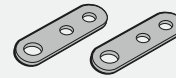

(2) 3-Hole Adjustment Clips



(2) S-hooks

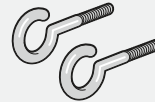

(2) 5/16" Eyebolts



(2) Black Bushings

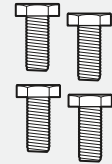

(4) 3/8" x 1-1/4" Sheave Bolts

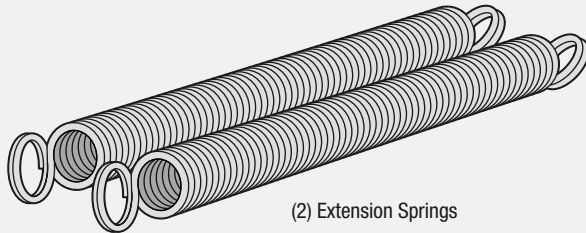

(2) Extension Springs



(4) 5/16" Flange Nuts



(4) 3/8" Flange Nuts

## TOOLS NEEDED (not included)

- 9/16" Wrench or Adjustable Wrench
- 9/16" Socket and Socket Wrench
- C-clamps
- Sawhorses
- Safety Glasses
- Gloves

## ASSEMBLY COMPONENTS

- 1 Sheave (Mounts on existing Angle Bracket)
- 2 Sheave
- 3 Sheave Fork
- 4 Extension Spring
- 5 Eyebolt
- 6 S-hook
- 7 3-Hole Adjustment Clip
- 8 Safety Containment Cable

Single assembly shown. Parts are identical on left and right assemblies. Both assemblies required to complete installation.

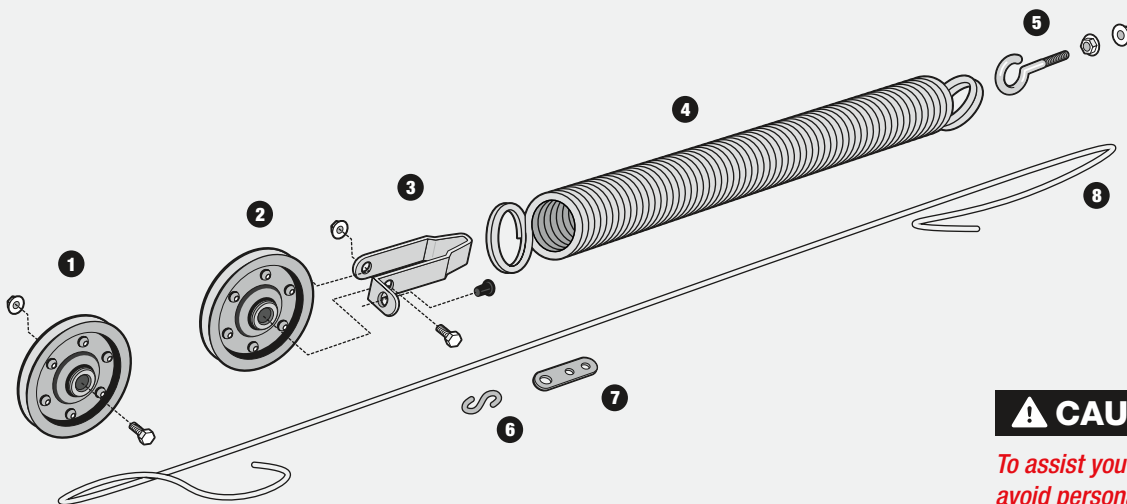

### **CAUTION**

*To assist you and to avoid personal injury or property damage, read and understand these instructions completely.*

All instructions are described from inside looking out.

## PARTS NEEDED FOR THIS STEP

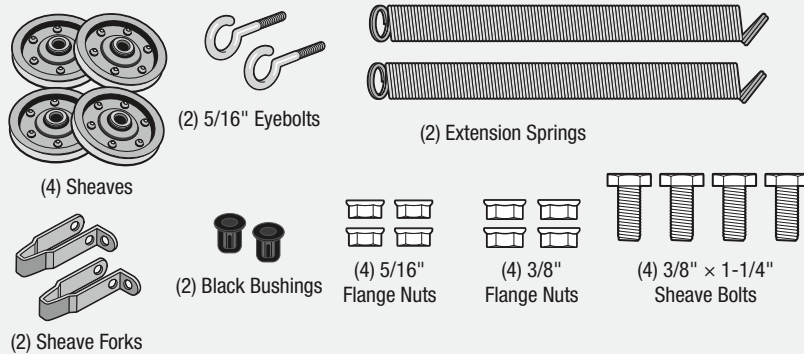

## TOOLS NEEDED FOR THIS STEP

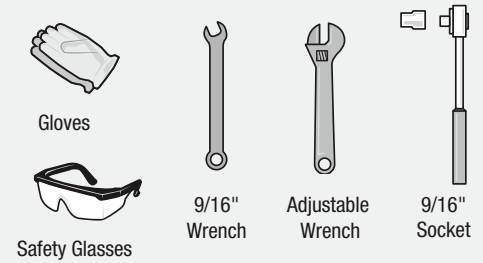

## Step 9-1

- On the floor, assemble each spring unit using (1) spring, (1) sheave fork, (1) sheave, (1) black bushing, (1) 3/8" × 1-1/4" bolt and (1) 3/8" flange nut (Fig. 9-A).

Fig. 9-A

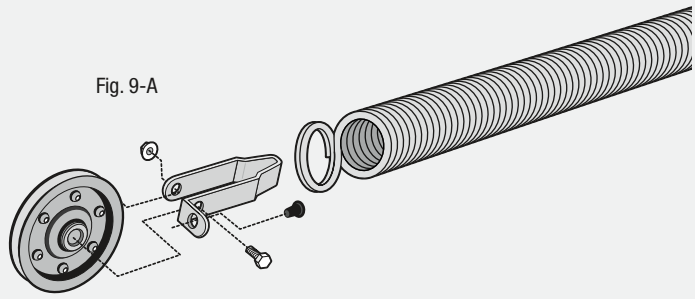

## Step 9-2

- Attach one of the remaining sheaves in the third hole of angle bracket approximately 4" from wall on both sides using (1) 3/8" × 1-1/4" bolt and (1) 3/8" flange nut (Fig. 9-B).

**NOTE:** Head of the bolt must be on the door side.

Fig. 9-B

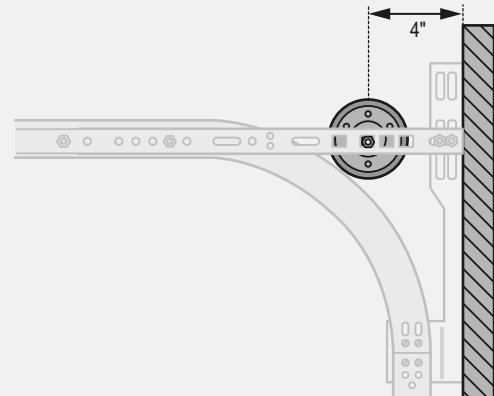

## Step 9-3

- Attach eyebolts with (1) 5/16" nut on each side of the rear hangers about 12" above the track to keep spring assembly from dragging on the track.
- Tighten eyebolt nuts (Fig. 9-C).

**NOTE:** Eyebolts can be as low as 4 inches above the track if you have space problems.

Fig. 9-C

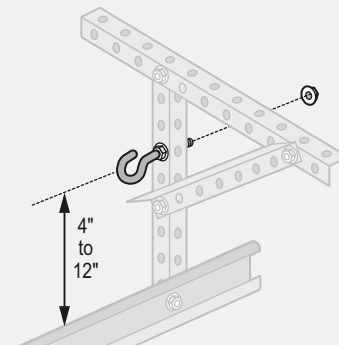

## PARTS NEEDED FOR THIS STEP

Adjustments in this Step are to  
Parts Already Assembled

## TOOLS NEEDED FOR THIS STEP

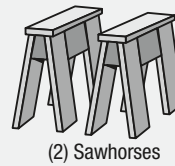

(2) Sawhorses

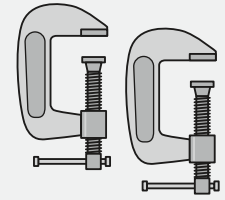

(2) C-clamps

## Step 9-4

- Slowly and carefully raise door and prop it about halfway open using saw horses (Fig. 9-D).

**! WARNING**

*This is the first time the new door is being opened. If the tracks are not correctly aligned or the back hangers are not strong enough the door may fall causing serious injury or damage to the door. The door will be heavy without the help of the springs. Have two or more people help you.*

- With door propped open, check to be sure horizontal tracks are parallel with each side of door. With door about halfway open, make sure rollers do not come out of top brackets more than 1/2". If rear hanger adjustments are necessary, lower door first because the weight of door is supported by the rear hangers.

**! WARNING**

*If tracks are not parallel with door, rollers could come out of hinges or brackets causing the door to fall and resulting in serious injury or death.*

## Step 9-5

- Carefully raise door to fully open position.
- Place C-clamps on both sides of track below bottom rollers to keep the door from falling closed (Fig. 9-E).
- Check again to be sure the horizontal tracks are parallel with the edges of the door. The rollers must not come out of the hinges or brackets.

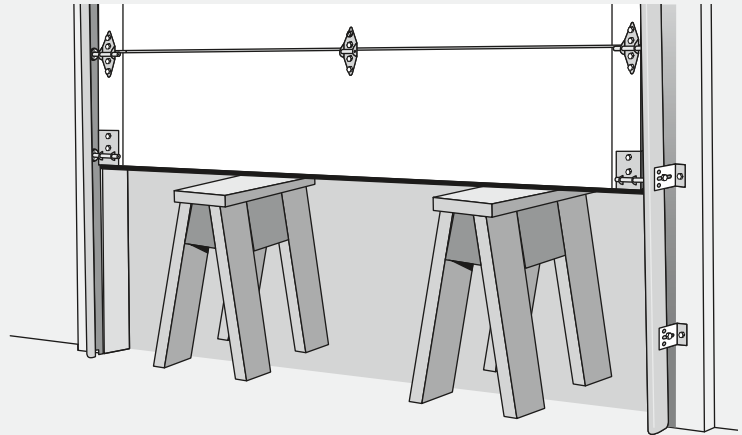

Fig. 9-D

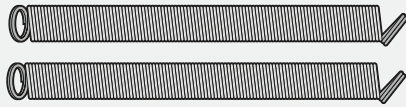

Fig. 9-E

# 9

# ASSEMBLE EXTENSION SPRINGS

## PARTS NEEDED FOR THIS STEP



(2) Extension Springs

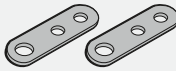

(2) 3-Hole Adjustment Clips



(2) S-hooks

## TOOLS NEEDED FOR THIS STEP



Gloves



Safety Glasses

### Step 9-6

- Hook the ends of the springs over the eyebolts at rear track hangers (Fig. 9-F).
- Using the cable attached to bottom bracket, thread cable up over the stationary sheave (Fig. 9-G).
- Continue to thread cable over and around sheave on the springs (Fig. 9-H).

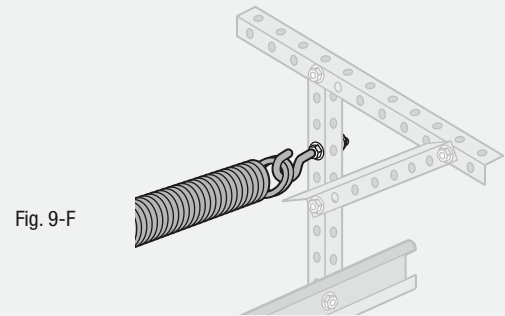

Fig. 9-F

### Step 9-7

- Tie cable to the 3-hole adjustment clip (Fig. 9-I).
- Hook cable to horizontal angle with an S-hook.
- Adjust knot at the 3-hole adjustment clip so all spring tension is relieved and cable holds the springs above horizontal track (Fig. 9-I).

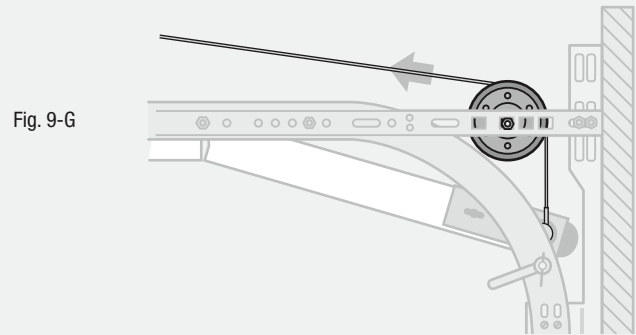

Fig. 9-G

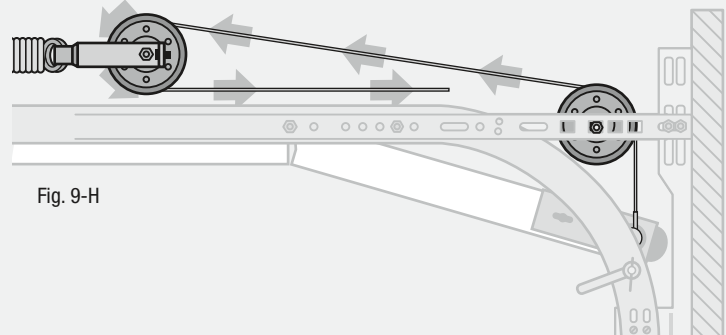

Fig. 9-H

**NOTE:** Springs should be stretched the same distance on both sides of the door.

**IMPORTANT:** Attach warning tag found in white envelope with orange print to the spring assembly (this tag may already be attached).

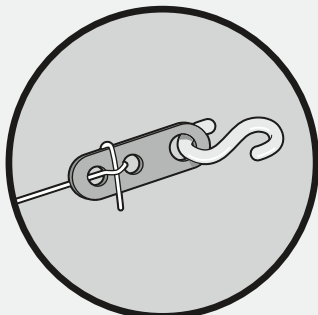

Fig. 9-I

## PARTS NEEDED FOR THIS STEP



(2) Safety  
Containment Cables

## TOOLS NEEDED FOR THIS STEP



Gloves



Safety Glasses

## Step 9-8 Installing Safety Containment Kit

**⚠ WARNING**

*Safety containment cables must be installed at this time. Garage door extension springs can cause serious injury and property damage if they break under tension and are not secured with safety cables.*

- Tie one end of the 1/8" safety containment cable to rear track hangers (Fig. 9-K).
- Thread safety containment cable through center of extension spring and through bushing in the sheave fork.
- Tie remaining end to horizontal angle as shown (Fig. 9-L).
- This must be done for each spring.

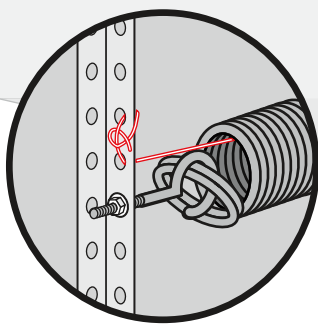

Fig. 9-K

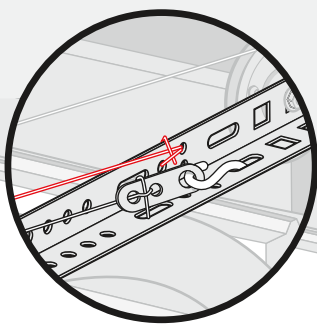
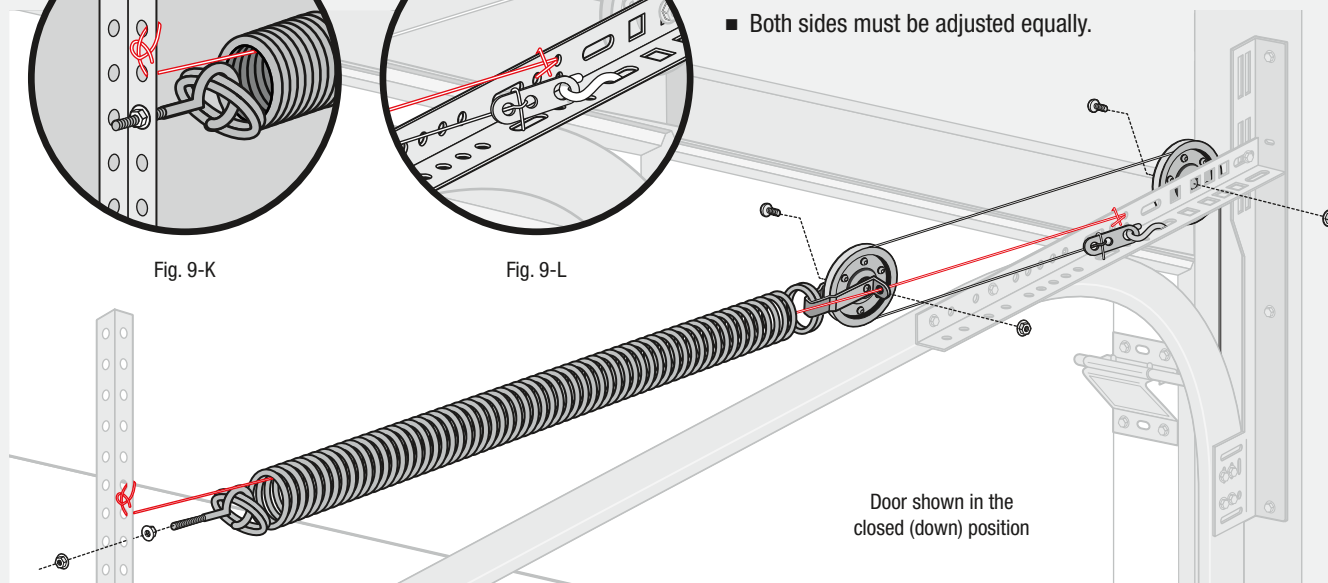

Fig. 9-L



Door shown in the  
closed (down) position

## Step 9-9 Adjust Spring Tension

**⚠ WARNING**

*Use extreme care when readjusting extension springs and make sure that the door is carefully secured by C-clamps in the open position before you begin. When the door is closed, the springs and mounting hardware are under extreme tension and are potentially dangerous. Failure to follow these instructions could cause release of spring energy resulting in injury or property damage.*

- Tension can be changed by moving the S-hooks to different holes in the horizontal track angles or by adjusting cable in the 3-hole adjustment clip (Fig. 9-L).

**NOTE:** Move hooks closer to door to increase tension and away from door to reduce tension.

- Tension can also be adjusted slightly by releasing spring tension and relocating eyebolts higher on track hanger.

**NOTE:** When reinstalling, the higher the eyebolt, the greater the tension.

- Both sides must be adjusted equally.

**⚠ WARNING**

*This is the first time new door is being opened fully. If tracks are not correctly aligned, or back hangers are not strong enough, door may fall causing serious injury or property damage. Proceed slowly and carefully.*

**Step 10-1 Lifting the Door for First Time****⚠ CAUTION**

*Prior to opening door fully or attaching an automatic opener, ensure door will clear brackets and winding unit. Failure to check this could result in damage to door.*

- Using pull rope, slowly and carefully lift door to full open position.

**⚠ WARNING**

*Do not place fingers in or near section joints. Doing so could result in finger pinch injury.*

- Door should lift easily and smoothly to fully open position and remain at top of opening until pulled closed. If door feels heavy and wants to fall closed, there is not enough tension on spring. If door lifts open rapidly, there may be too much tension on spring.
- Refer to spring instructions in Step 9-9 to verify springs are adjusted properly. Make necessary adjustments.

**Step 10-2 Check Horizontal Track**

- Once door is in fully open position, check horizontal tracks to be sure they are parallel with door.

**⚠ WARNING**

*If tracks are not parallel, this could cause door to bind or to fall from opening, resulting in serious injury or death. Refer to Step 7 to make necessary adjustments.*

**Step 10-3 Close Door, Check Operation**

- Using pull rope, close door fully. Once door can be opened and closed fully, check operation for smooth operation by opening and closing several times.

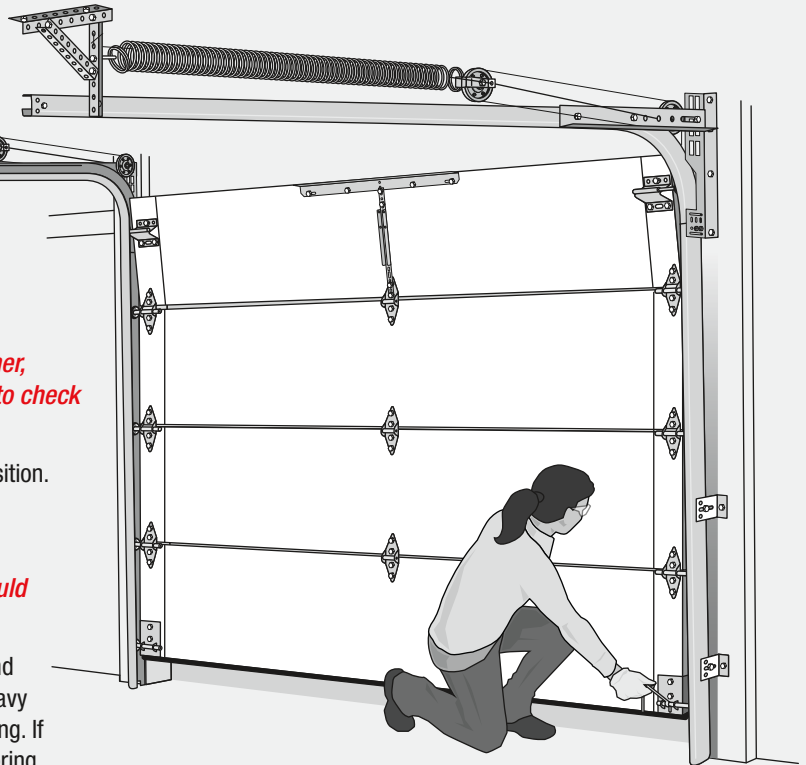
**Step 10-4 Permanently Attach Stop Mold**

- Make any final adjustments to stop mold as necessary. Take care stop mold is not too tight against door or this could cause rubbing.
- Put remainder of finishing nails into stop mold for secure attachment (Fig. 10-A).

Fig. 9-A



# 11 ATTACHING OPENER

**NOTE:** To avoid damage to your door, you must reinforce the top section of the door in order to provide a mounting point for the garage door opener to be attached. Refer to STEP 4 for specific instructions. DO NOT use the bracket that came with your opener or attach it directly to the door. Failure to reinforce the door as illustrated will void the warranty on your door.

## ⚠ WARNING

To avoid risk of strangulation or personal injury, if your door has a pull rope, you must remove pull rope when you install an automatic garage door opener.

### Step 11-1 Remove Pull Rope and Locks

- If you have installed pull rope, remove it now (Fig 11-A).

## ⚠ CAUTION

If you have installed a door lock, unlock or remove at this time. Failure to do so may cause damage to the door and void the warranty.

### Step 11-2 Install Opener Rail and Head

- Make sure to follow garage door opener manufacturer's installation and safety instructions for installing opener rail.
- To prevent top of door from bending, opener rail should be mounted no less than 2" and no greater than 5" from face of door in open position (Fig 11-B).

### Step 11-3 Attach Opener Arm to Door

- With the door in down position, use supplied clevis pin to attach opener arm to vertical opener reinforcement bracket at roughly same height as top roller of door. Opener arm should be approximately 60° from vertical opener bracket (Fig. 11-C).

### Step 11-4 Test the Opener

- Follow manufacturer's door opener instructions to test your garage door opener.

Fig. 11-A

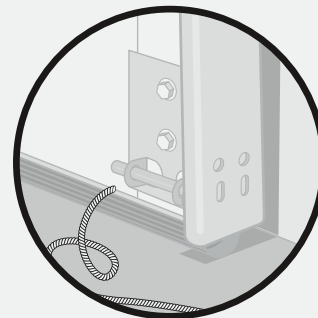

Fig. 11-B

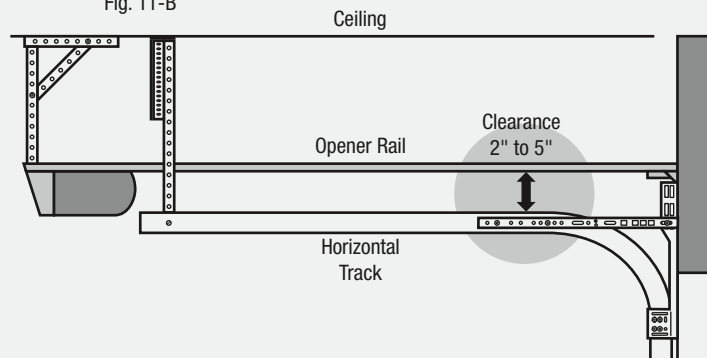
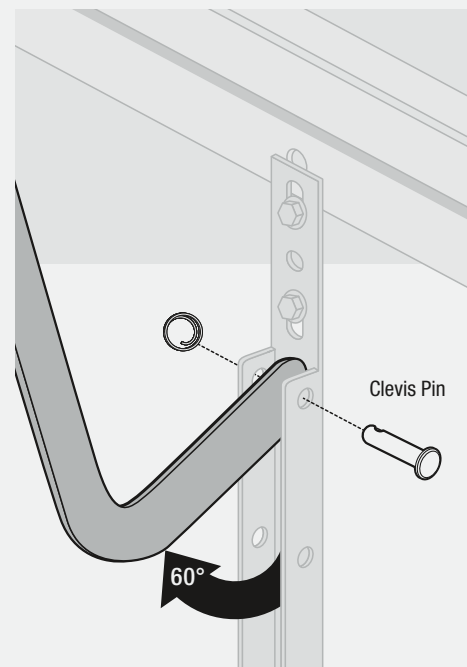
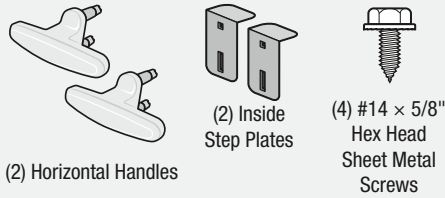

Fig. 11-C



## PARTS NEEDED FOR THIS STEP



## TOOLS NEEDED FOR THIS STEP

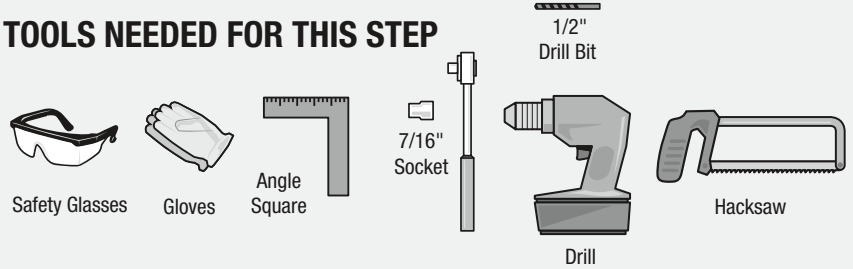

### Step 12-1 Prepare Lift Handles

**NOTE:** If installing an outside keyed lock assembly, refer to lock assembly instructions for next section and drill hole pattern for bottom section directly in line with the lock.

**IMPORTANT:** Use wrench or socket to drive screws. DO NOT over tighten or use a powered drill or driver.

- Cut the stems on the lift handles along the ridge line using a hacksaw (Fig. 12-A).

Fig. 12-A

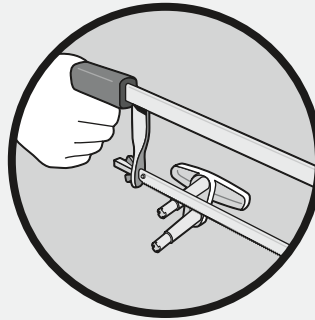
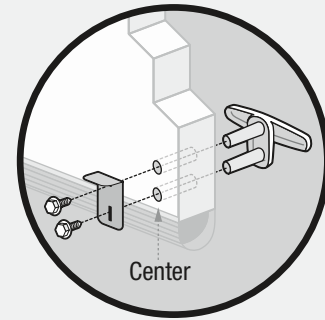

Fig. 12-D



### Step 12-2 Attach Lift Handles First (Bottom) Section

- From front side of door section, drill (2) 1/2" holes through section according to First (Bottom) Section Hole Pattern (Fig. 12-B). Do not use the pre-stamped hinge holes for lift handle placement. Use angle square to ensure vertical alignment.

Install lift handle and inside step plate assembly using (2) #14 × 5/8" sheet metal screws (Fig. 12-D).

Fig. 12-B

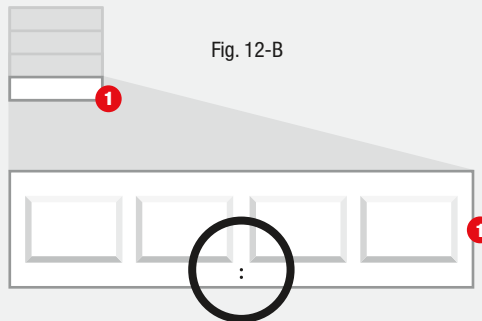

First (Bottom) Section Hole Pattern (Front Side)

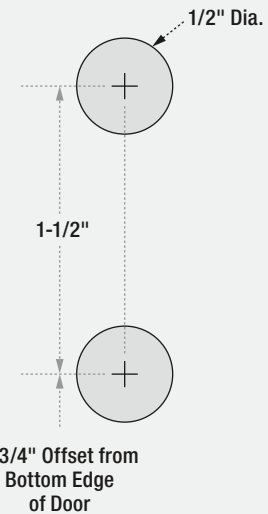

### Step 12-3 Attach Lift Handles Second (Middle) Section

- From front side of door section, drill (2) 1/2" holes through section according to Second (Middle) Section Hole Pattern (Fig. 12-C). Do not use the pre-stamped hinge holes for lift handle placement. Use angle square to ensure vertical alignment.

Install lift handle and inside step plate assembly using (2) #14 × 5/8" sheet metal screws (Fig. 12-D).

Fig. 12-C

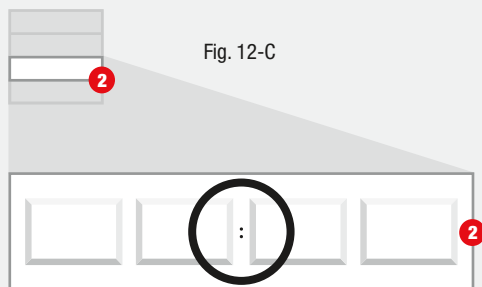

Second (Middle) Section Hole Pattern (Front Side)

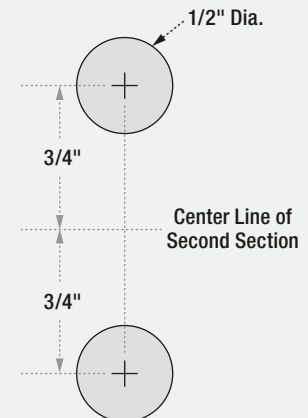

# APPENDIX

## A - CHECK HEADROOM, BACKROOM, SIDEROOM

Headroom is the space needed above top of door for door, overhead tracks and springs. Measure to check that there are no obstructions in garage within that space (Fig. A-1).

- The rough opening should be same size as door.

### HEADROOM REQUIREMENT:

MODEL	Spring	Radius	Headroom
84A	Extension	12"	10"
HDS	Extension	12"	10"
HDB, HDBL	Extension	12"	10"

**NOTE:** If there is restricted headroom, there are low headroom options available. Installation of low headroom options differ from installation of standard headroom options. See supplemental instructions included with low headroom option.

### LOW HEADROOM OPTION (NOT INCLUDED):

Reduce Headroom to 4-1/2"

Low Headroom Conversion Kit

(In Store - SKU 773-844, Online - 100021966)

- If you have less than 4-1/2" contact Clopay Customer Service for additional remedies.

### BACKROOM REQUIREMENT:

- Measured from back of door into garage, and should be at least 18" more than height of garage door.

### SIDEROOM REQUIREMENT:

- Minimum 3-3/4" is needed on each side of door on interior wall surface to allow for attachment of vertical track assembly.
- Minimum 4-1/2" is needed on each side of door above opening for spring attachment.

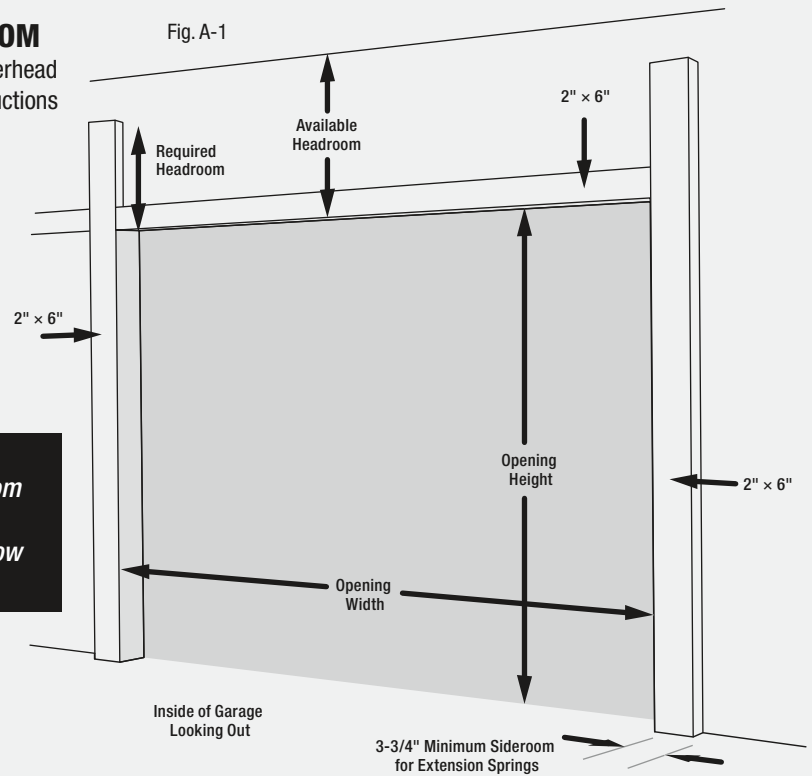

# APPENDIX

## B - REMOVING THE EXISTING DOOR SPRINGS

**NOTE:** Garage doors use springs to balance door weight. Springs are one of two types – extension or torsion. Each of these is available in either a standard or EZ-SET® assembly option.

- Use illustration in Fig. B-1 to determine which springs your door has. The following instructions detail how to remove these springs. If you do not see your spring type, please consult spring manufacturer.

### ⚠ WARNING

*Serious injury could result from an uncontrolled release of spring forces if spring tension has not been released before other work begins.*

### ⚠ WARNING

*To avoid pinch and other crushing injuries, keep hands and fingers clear of section joints, track and other door parts while door is opening and closing.*

**NOTE:** Some large doors might weigh as much as 500 pounds and single car doors as much as 200 pounds when the spring tension is removed.

### B.1 - STANDARD TORSION SPRINGS

#### ⚠ WARNING

*If present door uses standard torsion springs, DO NOT attempt to remove door or springs yourself. They should be removed by a qualified door service professional. Attempting to remove a torsion spring assembly without proper training and tools may result in an uncontrolled release of spring forces which can cause serious injury.*

### B.2 - REMOVING STANDARD EXTENSION SPRINGS

#### ⚠ WARNING

*Extension adjustments or removal should only be made with door in up position. To avoid damage or serious injury from door falling, use two or more helpers to assist in lowering door.*

#### Step 1:

- Raise door to full open position.
- Place C-clamps or locking pliers tightly on both sides of track under door so door is held securely in place (Fig. B.2-1).
- With door fully open, most spring tension has been removed.

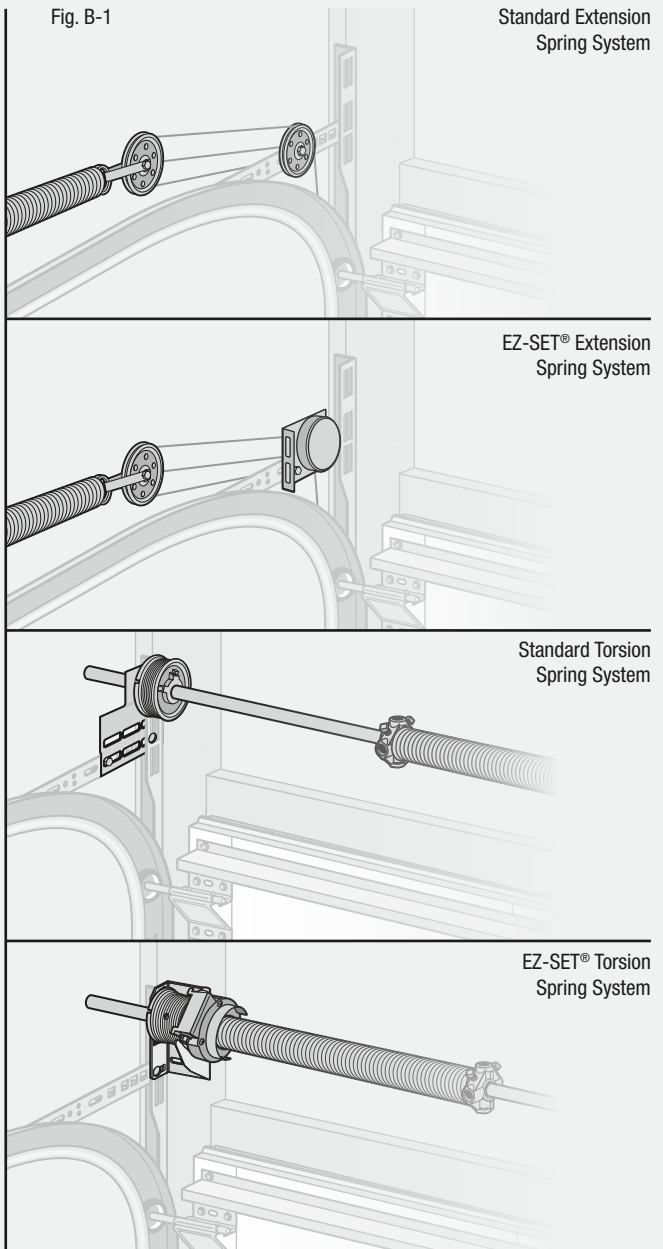

Fig. B.2-1



# APPENDIX

## Step 2:

- Keeping C-clamps in place to keep door from falling, detach cable at both ends.
- Disassemble and remove springs and cable completely from door.

**NOTE:** Wood blocks should be placed underneath the door when closing to prevent fingers from being trapped.

## Step 3:

- Remove C-clamps from track and carefully close door.
- Weight of door will not be apparent when you first begin to close door. Door will feel progressively heavier as it is lowered until its full weight is realized about one foot from floor.

## B.3 - REMOVING EZ-SET® EXTENSION SPRINGS OR EZ-SET® TORSION SPRINGS

### ⚠ WARNING

*To avoid damage or serious injury, use two or more helpers to assist in lowering door. EZ-SET® torsion springs adjustments or removal should only be made with door in down position.*

## Step 1:

- With door in down position, position drill with 7/16" socket bit over winding unit.
- Using reverse (counter-clockwise) direction on drill, remove all tension from spring (repeat for each side, if applicable) (Fig. B.3-1).
- After spring tension has been removed, detach lift cables at both ends.
- Disassemble and remove springs and cable completely from door.

Fig. B.3-1

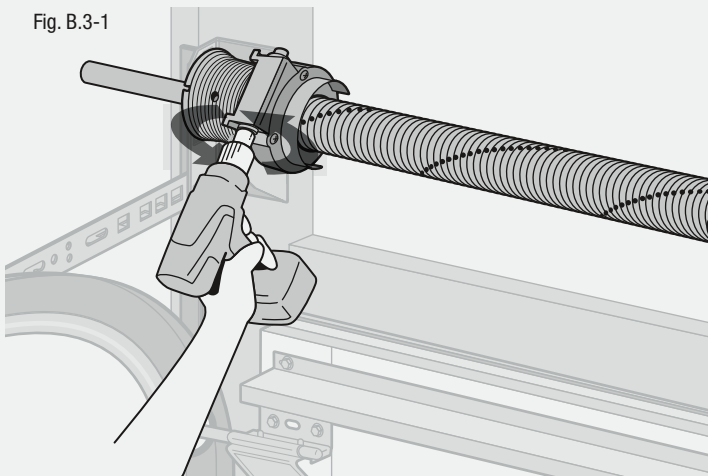
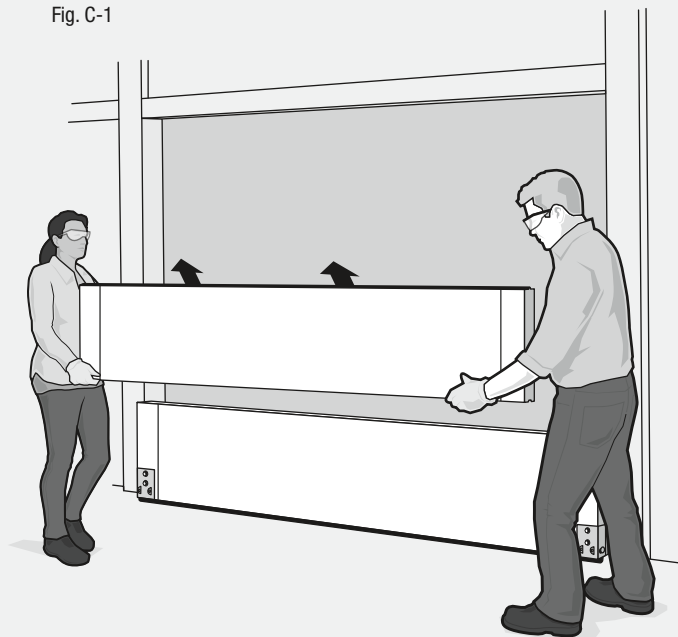

Fig. C-1



## C - REMOVING DOOR SECTIONS AND TRACK

Door can now be disassembled.

## Step 1:

- Starting with top section, remove hardware and unstack sections one at a time (Fig. C-1).

## Step 2:

- After all sections have been removed from opening, detach all remaining track and hardware from jambs.

- Hangers that attach rear ends of overhead track to ceiling (rear track hangers) in many cases can be reused on new door. Be sure they are made of 13 ga. (3/32") or heavier steel and are not loose or unstable.

### ⚠ WARNING

*To avoid installation and operation problems from using worn, damaged or incompatible track, use only track specified and supplied with door. DO NOT attempt to reuse old track.*

# APPENDIX

## D - PAINTING DOOR

This Clopay garage door can be painted with high quality 100% acrylic latex (flat, satin or semigloss) exterior grade paint.

### **⚠ CAUTION**

*Do not use any type of oil-based paint or alkyd modified paint. These paints will void the warranty of your door. We recommend using solar reflective paint when available.*

*If your door is a Coachman® Collection product:*

*You must check the Light Reflectance Value (LRV) of the paint color. If the desired color has an LRV less than 38, only a pre-approved solar reflective paint can be used. For a list of pre-approved paints, call the consumer services hotline at 1-800-621-3667 or visit [info.garagedoors.com/lrv](http://info.garagedoors.com/lrv)*

### Step 1: Painting preparation

Before painting the door it must be free of dirt, oil, caulk, waxes and mildew.

- Make a solution of trisodium phosphate (or a biodegradable cleaner) using 1/3 cup of powder to 1-1/2 to 2 gallons of water.
- Saturate cleaning pad (3M synthetic steel wool - gray not green) and rub with even pressure to lightly scuff surface while applying the cleaning solution over all surfaces to be painted.
- Rinse with clean water and sponge, changing water often.
- A final wipe and rinse with clean water and sponge should be done to remove any loose material.

**NOTE:** *If door has been waxed, wax must be removed before cleaning. Using moderate pressure, wipe the door surface with a rag saturated with xylene (xylol). Do not allow it to sit on door for extended time.*

**NOTE:** *Sanding could remove rust-inhibiting compounds. Sanding should be done only to damaged areas where bare metal has been exposed. Refer to "Paint repair" section below.*

### Step 2: Pretest paint

All paints are not created equal, the following test needs to be performed:

- Apply paint on small area of door (following instructions on paint container).
- Allow paint to dry and evaluate for any blistering or peeling.
- Perform adherence test by applying strip of masking tape over painted area and peel back tape. Check to see that paint adheres to door and not to tape.

**NOTE:** *If paint shows signs of poor adherence there may be a problem with the paint or surface preparation. DO NOT PROCEED! A new paint or further preparation of surface is required.*

### Step 3: Paint door

Follow directions on paint container and apply to door. Be sure to allow adequate drying time should you wish to apply a second coat.

**NOTE:** *Do not apply paint when door surface temperature is different from manufacturer's suggested temperature range for application.*

**NOTE:** *Window frames and inserts can be painted with a high quality, 100% acrylic latex. The plastic should first be lightly sanded to remove any surface gloss.*

### Paint repair:

Should door's paint finish become damaged, exposing bare metal, it will become necessary to repair this area to prevent rust from forming.

- Damaged area should be lightly sanded with medium to fine sandpaper, making sure to remove all visible red and white rust.
- Wipe this area with dry, clean rag.
- Coat sanded area with high quality, rust inhibiting, zinc enriched primer. This can be found at most paint or hardware stores and should be labeled for covering bare and galvanized steel.
- Wait time specified on the primer's instructions before proceeding with painting door.

# APPENDIX

## E - ANNUAL MAINTENANCE AND CLEANING

Door will need regular inspection, lubrication and cleaning to keep all parts in good working order and to help protect it from the elements.

### **⚠ WARNING**

*A sectional garage door is a large, heavy object that moves with the help of springs under high tension. Springs, bottom brackets, cables and supports are under high tension and can cause death or serious injuries if not properly handled. If door is inoperable or difficult to move, do not attempt these maintenance steps and contact a trained service person.*

### E.1 - VISUAL INSPECTION AND LUBRICATION

#### Inspecting the Door:

Visually inspect door every three months for worn or broken parts using checklist below. If something seems out of balance or adjustment, the door may be unsafe to operate. Contact a trained service person for assistance.

- 1 Visually examine door for loose or bent hinges:
  - Tighten loose hinges.
  - Straighten or replace bent hinges.

### **⚠ WARNING**

*Door must be locked and in down position. No more than one hinge to be removed from door at any given time. DO NOT loosen or remove bottom bracket with spring tension engaged as this may result in serious injury or property damage.*

- 2 Visually inspect rollers for broken wheels, bent shafts or worn out bearings.
- 3 Visually examine door and track supports for loose or missing bolts, screws, etc.
- 4 Visually examine track for creases or bends.
- 5 Visually examine door panels for signs of cracking or fatigue.
- 6 Spring system:
  - Visually inspect springs and components for damage. If the spring looks worn or broken it will need replaced.

### **⚠ WARNING**

*DO NOT operate door with a broken spring, doing so can cause serious injury or death. Contact a trained service person to replace spring.*

- Visually inspect cables for wear at bottom bracket button and make sure they run properly in drums.
- 7 Be sure all handles are properly attached and functioning properly before lifting the door manually.

### **⚠ WARNING**

*DO NOT manually operate door if handles are not installed. Doing so can cause finger pinch or crushing injury or amputation.*

- 8 For doors with automatic operators:
  - Make sure that the operator has a working safety feature. Photo eyes should be mounted to the left and right sides of the bottom of the door opening.
  - Retest monthly following manufacturer's instructions.
  - Remove pull down ropes and remove or disable door locks.
  - Be sure there is a way to manually detach opener.
  - Top section of door must be reinforced to support opener. Make sure this is securely attached to door.
- 9 After visually inspecting door, and all of its components, it is time to check door operation. With door in the down position, detach opener (if applicable) and lift door manually to ensure it is in good operating order.
  - Door should lift and lower easily.
  - It should not be too difficult to move or move more quickly than force applied.

Be sure to reattach opener once you ensure door is operating properly.

**NOTE:** *If door is too difficult to move, opens too quickly, or rollers come out of track, immediately discontinue use of door and contact a trained service technician.*

#### Lubricating the door:

Regularly lubricate all moving parts of door with Clopay® Garage Door Pro Lube or a synthetic lubricant, including:

- Lift cables at bottom bracket button.
- Bearings on spring system.
- Lock hardware where surfaces turn or slide.
- Full length of torsion spring to reduce friction between coils.
- Steel roller shaft where it sits in the hinge.

**DO NOT** lubricate nylon rollers.

# APPENDIX

## E.2 - CLEANING AND PRESERVING THE DOOR

Doors must be cleaned and waxed at least twice a year or four times a year for harsh environments (such as coastal regions, high road salts, etc.).

- Helps prevent damage (surface rust) caused by foreign matter or salt adhering to the door.
- Assist to restore the look of factory-applied finish by removing dirt and chalking.

**NOTE:** Failure to properly clean and preserve your door (particularly, but not limited to, high-salt or acidic environments) may result in surface rust, which may result in loss of warranty coverage.

For further questions about the requirements, contact Clopay Customer Service.

### To Clean the Door:

- 1 Working from top to bottom of the door sections, use a well soaked cloth, sponge, soft bristle brush, or low pressure garden sprayer with either of the following solutions:
  - One cup of non-toxic biodegradable cleaner (less than 0.5% phosphate) into two gallons of warm water, or
  - Household liquid dish washing detergent.

### ⚠ CAUTION

*Never blend cleaners or ammonia with bleach. DO NOT use scouring powders or solvents.*

- 2 Rinse door with clean water and allow to dry.

**NOTE:** Be sure to clean behind stop molding on sides and top of door.

### Waxing the Door:

After cleaning, use liquid car wax (not paste) to preserve the door's finish between cleanings. This is especially important in coastal and harsh environments.

## E.3 - WINDOW CLEANING AND CARE INSTRUCTIONS:

### Cleaning the Windows:

- 1 Clean with a mild solution of a dishwashing detergent and a soft cloth. DO NOT use any ammoniated, abrasive or solvent-based cleaners of any kind.
- 2 Rinse thoroughly.

### ⚠ CAUTION

*Use care when handling decorative windows to avoid scraping or scratching surface.*

**NOTE:** Minor scratches or scuffs are not considered defects and will not be covered under window warranty.

### Optional Snap-In Insert Removal:

**NOTE:** DO NOT remove screws from window frame.

Decorative inserts are designed to snap in and out of window frame. Some doors with windows have a decorative insert attached behind window. They may be moved to outside of glass, or can be removed for cleaning or painting purposes.

- 1 Remove the insert's four tabs from under the edge of inside window frame. There is one tab on each side and one on top and bottom of insert.
- 2 Insert can be firmly pulled out of window.
- 3 Replacing insert is the reverse of process described for removal. The four tabs must be pressed under lip in window frame.
- 4 If preferred, insert can be snapped into frame on outside of glass.

### Glass Replacement:

### ⚠ WARNING

*To avoid injury, use extreme caution in handling glass window pane. When frame is removed, exposed steel edge of door may be sharp. Avoid contact with steel edges. Always wear safety glasses and gloves.*

If the door is equipped with windows, and glass should need replacement, follow the steps below:

- 1 With someone holding outside frame, remove screws from inside frame retainer.
- 2 Pull inside frame out of door.
- 3 Carefully remove broken or old glass.
- 4 Insert new glass. Glass should be 11" × 18-1/2" (standard panel windows).
- 5 With someone holding outside frame, reinsert screws into inside frame, securing glass.

# TROUBLESHOOTING

## Door Is Hard to Open from Closed Position

ISSUE	SOLUTION
1 Too little tension on spring.	1 Increase spring tension slightly. Verify spring coil length is set properly. <b>▲WARNING: See springs instructions for guidelines.</b>
2 Door is binding on door stop molding.	2 Adjust tracks or reset stops.
3 Top of door caught under inside edge of header.	3 Set header stop just past bottom edge of header.
4 Horizontal tracks raised above level.	4 Level tracks or increase spring tension slightly. <b>▲WARNING: See springs instructions for guidelines.</b>
5 Track distance from edge of door is incorrect, making track tight against door.	5 There should be 1/2" gap between edge of door and the tracks.

## Door Is Hard to Close from Open Position

ISSUE	SOLUTION
1 Too much tension on spring.	1 Reduce spring tension slightly. <b>▲WARNING: See springs instructions for guidelines.</b>
2 Sections are bowed.	2 Tighten 28" angle fasteners and secure in place. Be sure door is properly reinforced for opener. See Steps 4-2 and 4-4 for instructions.

## Daylight Can Be Seen at Inside Edges

ISSUE	SOLUTION
1 Stop mold not sealing against door.	1 Reset stop mold or replace, adjust tracks.
2 Opening oversized or jambs not plumb.	2 Add 3/4" trim or second jamb stop, caulk outside edges of stops, center door in opening.

## Bottom Section Hitting Stop Molding

ISSUE	SOLUTION
1 Stop molding is out of alignment.	1 Adjust stop molding.
2 Track bracket is not adjusted properly.	2 Loosen bracket, move door back from opening, retighten.
3 Bottom brackets are upside down.	3 See Step 2-3 for instructions.

## Door Moves Side-to-Side in Track

ISSUE	SOLUTION
1 Track distance from edge of door is incorrect.	1 Tracks too far apart: should be 3/8"-1/2" from edge of door.
2 Cables out of adjustment.	2 Check cable lengths are even.
3 Rear track hangers not placed correctly.	3 See Step 7-4 for proper installation.

## Door Hits Header

ISSUE	SOLUTION
1 Top roller bracket too high, stop molding is out of alignment.	1 Move top roller bracket down, loosen stop molding.
2 Jamb brackets or hinges are installed in wrong location.	2 Check for proper installation for jambs, brackets, hinges (numbers in correct location) and rollers.

# STEEL GARAGE DOOR LIMITED WARRANTY

Subject to the terms of this Limited Warranty ("Warranty") and any warranty policies and procedures in effect at the time a notice of a claim is received, Clopay Corporation ("Clopay", "we", or "our") will repair or replace (at our sole discretion) any garage door sections/section components, hardware, or springs/spring components (collectively, "Replacement Parts") that we determine to be defective in material or workmanship so long as timely written notice is provided within the applicable limited warranty periods provided below. This Warranty shall apply and benefit only the original purchase of a Clopay garage door product and is non-transferable.

The Warranty period begins from the date of delivery. Proof of purchase is required. Once we have verified any defect(s) with your Product through persons authorized by Clopay, we will provide – at no cost to you – Replacement Parts to the extent necessary to repair or replace any such defective sections, hardware, or springs/spring components. We reserve the right to inspect and/or verify any claimed defect, as well as the right to replace Product(s) or its components with a similar or like product or component, all within the sole discretion of Clopay. All labor costs associated with any warranty claim (including removal, reinstallation, installation, and/or finishing) will be your responsibility.

The applicable Warranty periods are as follows:

MODEL NUMBER	PAINT FINISH	SECTIONS/ DELAMINATION	WINDOWS	HARDWARE/SPRINGS
84A	Single Family* – Lifetime Other** – 10 Years Color Blast®† – 5 Years	5 Years	10 Years	3 Years
HDS	Single Family* – 25 Years Other** – 10 Years Color Blast®† – 5 Years			
75, HDB, HDBL	Single Family* – 15 Years Other** – 10 Years Color Blast® – 5 Years			

\* Applies to residential single family installations.

\*\* "Other" refers to all other residential installations (including installations on facilities owned in common by condominium associations or similar organizations).

## ADDITIONAL INFORMATION REGARDING YOUR WARRANTY

Clopay warrants the sections of the Models listed above against the paint finish cracking, checking or peeling (i.e. losing adhesion). We warrant our rust prevention system against rust through perforation(s) caused by corrosion originating at the steel layer. Surface rust – and rust through caused by untreated surface rust – is not covered under this warranty. Surface rust (a coating that forms on the surface when exposed to moisture) can result from failure to properly clean and maintain your door (particularly in, but not limited to, high-salt or acidic environments) or damage to the door (such as scratching). For more information about our rust prevention system and how to care for your door visit: [info.garagedoors.com/maintenance](http://info.garagedoors.com/maintenance)

Window components such as frames, grilles, inserts, and clear acrylic are warranted for ten (10) years from manufacturing defects and excessive yellowing. Insulated windows are warranted for ten (10) years for material obstruction of vision resulting from film formation or dust or moisture collection between the interior surface of the insulating glass. No warranty is available for single pane glass. No warranty is available for decorative hardware.

**EXCLUSIONS TO COVERAGE** This warranty shall not extend to damages or defects caused by any of the following:

Paint or Stain Not Applied per Manufacturer Specifications after Delivery of Door	Failure to Follow All Installation Instructions	Failure to Follow Maintenance Instructions	Faulty or Defective Installation(s)
Fire	Radiation (UV or Other)	Foreign Substances	Accident or Casualty
Harmful Fumes	Vandalism	Act(s) of God	Physical Damage
Salt Spray or Exposure	Normal Wear and Tear	Chemical Action	Abrasive Materials
Operation Beyond Rated Capacity	Improper Use or Abuse	Improper Installation or Handling	Exposure to Coastal Weather Conditions
Alteration, Modification or Use of Non-OEM/ Clopay-Approved Parts or Products	Other Painted Parts Not Part of a Door Section (such as stop mold)	Normal Fading or Discoloration from Usage, Age or UV Exposure	Thermal bow as described in DASMA Technical Data Sheet 185 <a href="http://www.dasma.com">www.dasma.com</a>

If you make any repair or alteration without first providing notice to and receiving authorization from us, or use any parts, accessories, or attachments other than authorized by Clopay for use in its products, you will be solely responsible for any such repairs or parts and you may void this Warranty. Routine maintenance and related items, as well as minor adjustments or damage caused by your installer either during delivery or installation, are excluded from this Warranty. For purposes of this Warranty, minor scratches will not be considered a defect.

If you would like to submit a Warranty claim, notify Clopay Customer Service promptly after discovery of the defect by sending an email to [warranty@clopay.com](mailto:warranty@clopay.com) or calling 800-225-6729. Please be prepared to send us a proof of purchase and complete description with photographs of any issues. YOU MUST REPORT ANY MANUFACTURING DEFECTS THAT ARE IMMEDIATELY OBVIOUS OR VISIBLE AT THE TIME OF INSTALLATION (SUCH AS INCORRECT OR INCONSISTENT PAINT COLOR, MANUFACTURING DEFECTS (E.G. SURFACE CONTAMINANT(S) OR SMUDGES), VISIBLE PHYSICAL DAMAGE, OR MAJOR SCRATCHES) WITHIN FORTY FIVE (45) DAYS FROM DELIVERY OR YOUR CLAIM MAY BE BARRED. Additional copies of our installation and maintenance instructions may be obtained by calling 800-225-6729.

UNDER NO CIRCUMSTANCES SHALL WE BE LIABLE FOR ANY CONSEQUENTIAL OR SPECIAL DAMAGES WHICH ANY PERSON OR ENTITY MAY INCUR OR CLAIM TO INCUR AS A RESULT OF ANY DEFECT IN THE PRODUCT OR IN ANY CORRECTION OR ALTERATION THEREOF MADE OR FURNISHED BY US OR OTHERS. OUR MAXIMUM LIABILITY UNDER THIS WARRANTY SHALL BE THE PURCHASE PRICE PAID TO US WITH RESPECT TO THE GARAGE DOOR TO WHICH SUCH WARRANTY IS CLAIMED. THE LIMITATION OF LIABILITY PROVISIONS HEREIN SHALL APPLY TO ANY AND ALL CLAIMS OR SUITS BROUGHT AGAINST US, INCLUDING ANY CLAIM BASED UPON NEGLIGENCE, BREACH OF CONTRACT, BREACH OF WARRANTY, STRICT LIABILITY OR ANY OTHER THEORIES UPON WHICH LIABILITY MAY BE ASSERTED AGAINST US.

This Warranty constitutes our entire and exclusive warranty as to the Product and is the sole and exclusive remedy for product defects in material and workmanship. We do not assume (and have not authorized any other person to assume on its behalf) any other warranty or liability in connection with any product covered by this warranty. WE MAKE NO OTHER WARRANTIES, REPRESENTATIONS OR COVENANTS, EXPRESS OR IMPLIED, WITH RESPECT TO THIS PRODUCT, INCLUDING BUT NOT LIMITED TO WARRANTIES, REPRESENTATIONS OR COVENANTS AS TO WORKMANSHIP, DESIGN, CAPACITY, QUALITY, CONDITION, MERCHANTABILITY OR FITNESS FOR ANY PURPOSE OF THE PRODUCT, EXCEPT FOR ANY "IMPLIED WARRANTY" AS THAT TERM IS DEFINED IN THE MAGNUSON-MOSS WARRANTY-FEDERAL TRADE COMMISSION IMPROVEMENT ACT, SUCH IMPLIED WARRANTIES TO BE LIMITED IN DURATION TO A PERIOD OF ONE YEAR FROM THE DATE OF PURCHASE.

This Warranty gives you specific legal rights, and you may also have other rights that vary from state to state.

To the extent of any conflict between this Warranty and any other document, this Warranty shall control. If Warranty is provided in multiple languages, the English language version shall govern.



Clopay® is a brand of Clopay Corporation.  
© 2023 Clopay Corporation. All rights reserved.

MOD C32-R10-0621