

installation instructions:

PVC RAFTERTAILS

SAFETY INSTRUCTIONS

Make sure to use the correct tools recommended.

Wear safety goggles.

Follow fixture, power tools, and paint manufacturers' instructions and users manuals.

Use common sense and follow good construction practices.

Rafterails are not load bearing, decorative use only.

TOOL & MATERIAL CHECKLIST

- electric drill
- wood blocks
- drill bit for pilot hole
- adhesive
- countersink bit
- caulking gun
- lag screws & washers
- mechanical fasteners
- caulk
- sandpaper

IMPORTANT INFO

- It is highly recommended that you paint/finish the rafterails before installation.
- Once installed, you can apply any necessary touchup paint/finish.
- Clean installation surface and bracket of all dirt and dust with a clean cloth or dry sponge.
- Measure and mark the location where the bracket is going to be installed.
- All PVC brackets are decorative only and for some models the legs (bracket extensions) are built as solid hollow channels to slip over wood blocking strips for easy installation.
- Wood blocking strips should fit snugly into the back of bracket.

INSTALL INSTRUCTIONS:

Hollow Rafterails

1. Attach wood blocks to surface with screws.
2. The top and back pieces of bracket will easily "slip" over wood blocking strips.
3. Screw through side of bracket into wood blocks to properly secure.
4. Use acrylic caulk to seal edges of bracket against surface after installation.
5. Fill in any holes with caulk and smooth the surface with finger.
6. Let caulk dry. Once dry, lightly sand with extra fine sandpaper.
7. Touchup bracket with paint as needed.

Solid Rafterails- TIE PLATE, OR TOENAIL

1. Mark placement of screw holes using a pencil or maker.
2. Drill a pilot the hold using a the proper sized drill bit for you lag screw.
3. If you wish to countersink the screws, use the countersink bit to drill a hole deep enough to hide the head of the screw.
4. Using the pilot hole fasten the rafter to the surface making sure that the screws lock into a post or beam.
5. Fill in the screw holes with caulk and sand to finish.

EXAMPLE DIAGRAM:

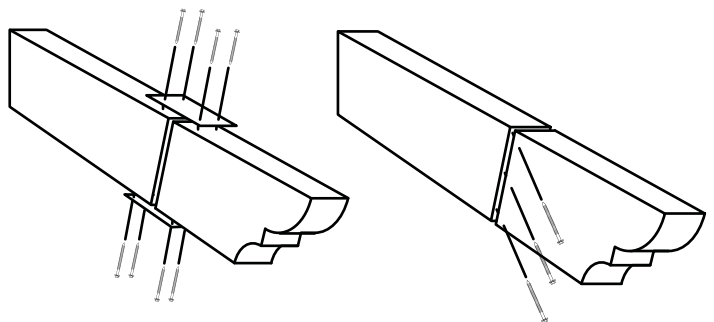
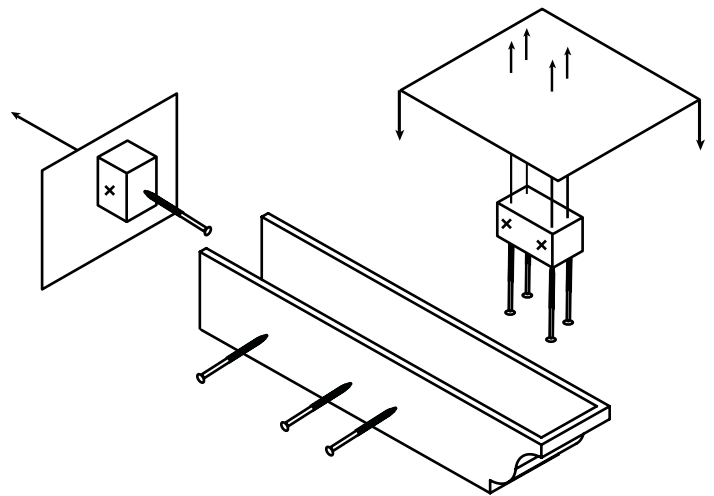

We Can Help. Call (866) 607-0453



EKENA
MILLWORK

Industry leading manufacturer of urethane, PVC, wood, rustic, and metal millwork

www.ekenamillwork.com