

# OPERATOR'S MANUAL

## OSCILLATING EDGE BELT/ SPINDLE SANDER

EB44241/EB44242/EB44243/EB4424

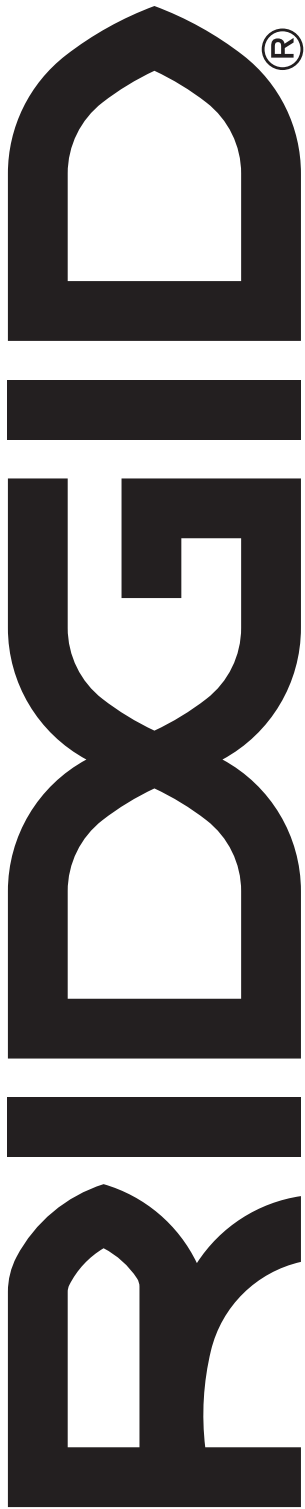

Shown with Edge Belt  
Sander attached.

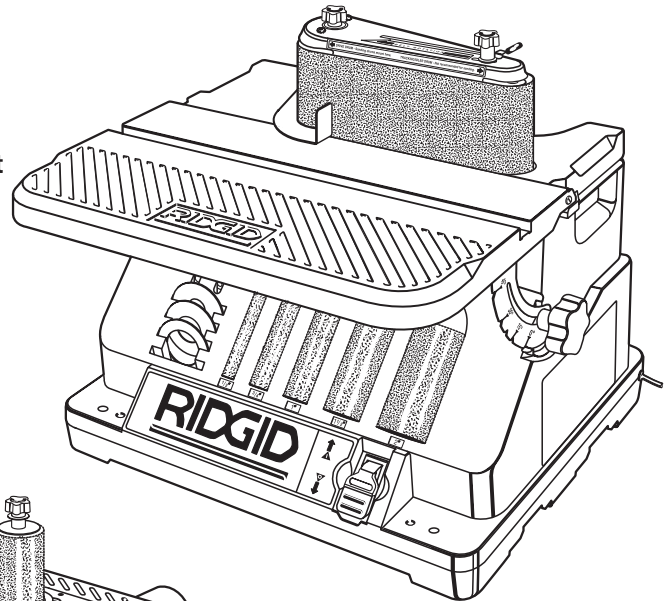

Shown with Spindle  
Sander attached.

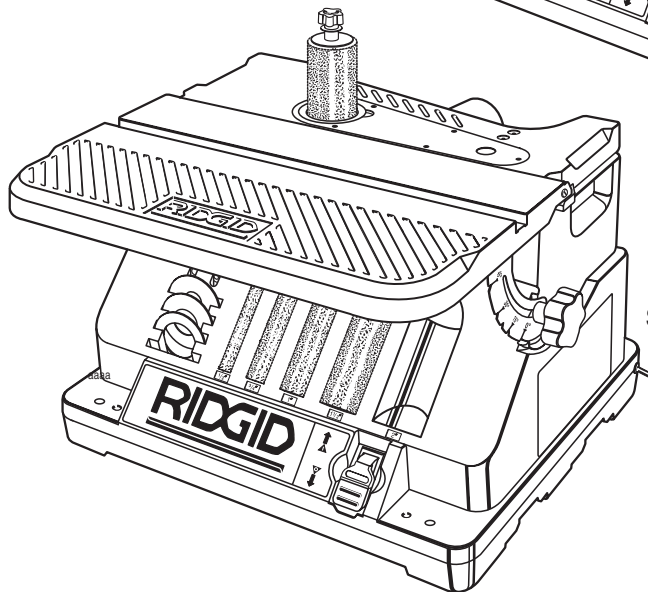

Your Oscillating Edge Belt/Spindle Sander has been engineered and manufactured to RIDGID's high standard for dependability, ease of operation, and operator safety. When properly cared for, it will give you years of rugged, trouble-free performance.

**⚠ WARNING:**

To reduce the risk of injury, the user must read and understand the operator's manual before using this product.

Thank you for buying a RIDGID product.

**SAVE THIS MANUAL FOR FUTURE REFERENCE**

# TABLE OF CONTENTS

---

■ Introduction.....	2
■ General Safety Rules .....	3-4
■ Specific Safety Rules.....	4
■ Symbols .....	5-6
■ Electrical .....	7
■ Glossary of Terms.....	8
■ Features .....	9-10
■ Tools Needed.....	10
■ Loose Parts.....	11
■ Assembly .....	11-16
■ Operation.....	17-19
■ Adjustments.....	20-21
■ Maintenance .....	22
■ Accessories .....	23
■ Troubleshooting .....	24
■ Warranty .....	25
■ Customer Service Information.....	26

## INTRODUCTION

---

This tool has many features for making its use more pleasant and enjoyable. Safety, performance, and dependability have been given top priority in the design of this product making it easy to maintain and operate.

# GENERAL SAFETY RULES

---

## **WARNING:**

Read and understand all instructions. Failure to follow all instructions listed below, may result in electric shock, fire and/or serious personal injury.

---

## READ ALL INSTRUCTIONS

- **KNOW YOUR POWER TOOL.** Read the operator's manual carefully. Learn the applications and limitations as well as specific potential hazards related to this tool.
- **GUARD AGAINST ELECTRICAL SHOCK BY PREVENTING BODY CONTACT WITH GROUNDED SURFACES.** For example: pipes, radiators, ranges, refrigerator enclosures.
- **KEEP GUARDS IN PLACE** and in working order.
- **REMOVE ADJUSTING KEYS AND WRENCHES.** Form habit of checking to see keys and adjusting wrenches are removed from tool before turning it on.
- **KEEP THE WORK AREA CLEAN.** Cluttered work areas and work benches invite accidents. **DO NOT** leave tools or pieces of wood on the tool while it is in operation.
- **DO NOT USE IN DANGEROUS ENVIRONMENTS.** Do not use power tools in damp or wet locations or expose them to rain. Keep the work area well lit.
- **KEEP CHILDREN AND VISITORS AWAY.** All visitors should wear safety glasses and be kept a safe distance from work area. Do not let visitors contact tool or extension cord while operating.
- **MAKE WORKSHOP CHILDPROOF** with padlocks, master switches, or by removing starter keys.
- **DON'T FORCE THE TOOL.** It will do the job better and safer at the rate for which it was designed.
- **USE THE RIGHT TOOL.** Do not force the tool or attachment to do a job for which it was not designed.
- **USE THE PROPER EXTENSION CORD.** Make sure your extension cord is in good condition. Use only a cord heavy enough to carry the current your product will draw. An undersized cord will cause a drop in line voltage resulting in loss of power and overheating. A wire gauge size (A.W.G.) of at least **16** is recommended for an extension cord 25 feet or less in length. If in doubt, use the next heavier gauge. The smaller the gauge number, the heavier the cord.
- **DRESS PROPERLY.** Do not wear loose clothing, gloves, neckties, or jewelry. They can get caught and draw you into moving parts. Also wear protective hair covering to contain long hair.
- **ALWAYS WEAR SAFETY GLASSES WITH SIDE SHIELDS.** Everyday eyeglasses have only impact-resistant lenses, they are **NOT** safety glasses.
- **SECURE WORK.** Use clamps or a vise to hold work when practical, it is safer than using your hand and frees both hands to operate the tool.
- **DO NOT OVERREACH.** Keep proper footing and balance at all times.
- **MAINTAIN TOOLS WITH CARE.** Keep tools sharp and clean for best and safest performance. Follow instructions for lubricating and changing accessories.
- **DISCONNECT TOOLS.** When not in use, before servicing, or when changing attachments, blades, bits, cutters, etc., all tools should be disconnected from power source.
- **AVOID ACCIDENTAL STARTING.** Be sure switch is off when plugging in any tool.
- **USE RECOMMENDED ACCESSORIES.** Consult the operator's manual for recommended accessories. The use of improper accessories may result in injury.
- **NEVER STAND ON TOOL.** Serious injury could occur if the tool is tipped.
- **CHECK DAMAGED PARTS.** Before further use of the tool, a guard or other part that is damaged should be carefully checked to determine that it will operate properly and perform its intended function. Check for alignment of moving parts, binding of moving parts, breakage of parts, mounting and any other conditions that may affect its operation. A guard or other part that is damaged must be properly repaired or replaced by an authorized service center to avoid risk of personal injury.
- **USE THE RIGHT DIRECTION OF FEED.** Feed work into a blade, cutter, or sanding spindle against the direction or rotation of the blade, cutter, or sanding spindle only.
- **NEVER LEAVE TOOL RUNNING UNATTENDED. TURN THE POWER OFF.** Don't leave tool until it comes to a complete stop.
- **PROTECT YOUR LUNGS.** Wear a face or dust mask if the cutting operation is dusty.
- **PROTECT YOUR HEARING.** Wear hearing protection during extended periods of operation.
- **DO NOT ABUSE CORD.** Never carry tool by the cord or yank it to disconnect from receptacle. Keep cord from heat, oil, and sharp edges.
- **USE OUTDOOR EXTENSION CORDS.** When tool is used outdoors, use only extension cords with approved ground connection that are intended for use outdoors and so marked.
- **KEEP BLADES CLEAN, SHARP, AND WITH SUFFICIENT SET.** Sharp blades minimize stalling and kickback.
- **NEVER USE IN AN EXPLOSIVE ATMOSPHERE.** Normal sparking of the motor could ignite fumes.
- **INSPECT TOOL CORDS PERIODICALLY.** If damaged, have repaired by a qualified service technician at an authorized service facility. The conductor with insulation having an outer surface that is green with or without yellow stripes is the equipment-grounding conductor. If repair or replacement of the electric cord or plug is necessary, do not connect the equipment-grounding conductor to a live terminal. Repair or replace a damaged or worn cord immediately. Stay constantly aware of cord location and keep it well away from the rotating blade.

# GENERAL SAFETY RULES

---

- **INSPECT EXTENSION CORDS PERIODICALLY** and replace if damaged.
- **KEEP TOOL DRY, CLEAN, AND FREE FROM OIL AND GREASE.** Always use a clean cloth when cleaning. Never use brake fluids, gasoline, petroleum-based products, or any solvents to clean tool.
- **STAY ALERT AND EXERCISE CONTROL.** Watch what you are doing and use common sense. Do not operate tool when you are tired. Do not rush.
- **DO NOT USE TOOL IF SWITCH DOES NOT TURN IT ON AND OFF.** Have defective switches replaced by an authorized service center.
- **INSPECT FOR AND REMOVE ALL NAILS FROM LUMBER BEFORE USING THIS TOOL.** Following this rule will reduce the risk of serious personal injury.
- **NEVER START A TOOL WHEN ANY ROTATING COMPONENT IS IN CONTACT WITH THE WORKPIECE.**
- **DO NOT OPERATE A TOOL WHILE UNDER THE INFLUENCE OF DRUGS, ALCOHOL, OR ANY MEDICATION.**
- **WHEN SERVICING** use only identical replacement parts. Use of any other parts may create a hazard or cause product damage.
- **USE ONLY RECOMMENDED ACCESSORIES** listed in this manual or addendums. Use of accessories that are not listed may cause the risk of personal injury. Instructions for safe use of accessories are included with the accessory.
- **DOUBLE CHECK ALL SETUPS.** Make sure the spindle or sanding belt assembly is tight and not making contact with sander or workpiece before connecting to power supply.











# SPECIFIC SAFETY RULES

---

- **FIRMLY CLAMP OR BOLT** your tool to a workbench or table at approximately hip height.
- **NEVER** stand or have any part of your body in line with the path of the workpiece.
- **PLAN YOUR WORK TO REDUCE THE RISK OF THROWBACKS** (when the workpiece catches the sanding drum and is torn from your hands).
- **MAKE SURE THERE'S NO DEBRIS** between the workpiece and its supports.
- **WHEN SANDING IRREGULARLY SHAPED WORKPIECES,** plan your work support so it will not slip and be pulled from your hands.
- **USE EXTRA CAUTION WITH LARGE,** very small or awkward workpieces.
- **NEVER USE THIS TOOL** to finish pieces too small to hold by hand.
- **USE EXTRA SUPPORTS (TABLES, SAW HORSES, BLOCKS, ETC.)** for any workpieces large enough to tip when not secured to the work surface.
- **NEVER** sand more than one piece at a time. **DO NOT STACK** more than one workpiece on the sander table at a time.
- **ALWAYS FEED WORKPIECE FROM LEFT TO RIGHT** against the direction the drum sleeve is rotating.
- **DO NOT USE DRUMS,** sanding sleeves or belts which show visual signs of wear such as grooves, tears or rips.
- **ALWAYS STAY ALERT!** Do not allow familiarity (gained from frequent use of your sander) to cause a careless mistake. **ALWAYS REMEMBER** that a careless fraction of a second is sufficient to inflict severe injury.
- **MAKE SURE THE WORK AREA HAS AMPLE LIGHTING** to see the work and that no obstructions will interfere with safe operation **BEFORE** performing any work using your tool.
- **ALWAYS TURN OFF THE SANDER** before disconnecting it to avoid accidental starting when reconnecting to power supply. **NEVER** leave the tool unattended while connected to a power source.
- **SUPPORT WORKPIECE** with miter gauge, work rest, or worktable.
- **MAINTAIN 1/16 IN.** clearance between worktable and sanding belt or disc.
- **AVOID KICKBACK** by sanding in accordance with directional arrows.
- **SAVE THESE INSTRUCTIONS.** Refer to them frequently and use them to instruct others who may use this tool. If you loan someone this tool, loan them these instructions also.

# SYMBOLS



Some of the following symbols may be used on this tool. Please study them and learn their meaning. Proper interpretation of these symbols will allow you to operate the tool better and safer.

SYMBOL	NAME	DESIGNATION/EXPLANATION
V	Volts	Voltage
A	Amperes	Current
Hz	Hertz	Frequency (cycles per second)
W	Watt	Power
min	Minutes	Time
~	Alternating Current	Type of current
==	Direct Current	Type or a characteristic of current
n <sub>0</sub>	No Load Speed	Rotational speed, at no load
	Class II Construction	Double-insulated construction
.../min	Per Minute	Revolutions, strokes, surface speed, orbits etc., per minute
	Wet Conditions Alert	Do not expose to rain or use in damp locations.
	Read The Operator's Manual	To reduce the risk of injury, user must read and understand operator's manual before using this product.
	Eye Protection	Always wear safety goggles or safety glasses with side shields and a full face shield when operating this product.
	Safety Alert	Precautions that involve your safety.
	No Hands Symbol	Failure to keep your hands away from the blade will result in serious personal injury.
	No Hands Symbol	Failure to keep your hands away from the blade will result in serious personal injury.
	No Hands Symbol	Failure to keep your hands away from the blade will result in serious personal injury.
	No Hands Symbol	Failure to keep your hands away from the blade will result in serious personal injury.
	Hot Surface	To reduce the risk of injury or damage, avoid contact with any hot surface.

# SYMBOLS

---

The following signal words and meanings are intended to explain the levels of risk associated with this product.

SYMBOL	SIGNAL	MEANING
	<b>DANGER:</b>	Indicates an imminently hazardous situation, which, if not avoided, will result in death or serious injury.
	<b>WARNING:</b>	Indicates a potentially hazardous situation, which, if not avoided, could result in death or serious injury.
	<b>CAUTION:</b>	Indicates a potentially hazardous situation, which, if not avoided, may result in minor or moderate injury.
	<b>CAUTION:</b>	(Without Safety Alert Symbol) Indicates a situation that may result in property damage.

## SERVICE

Servicing requires extreme care and knowledge and should be performed only by a qualified service technician. For service we suggest you return the product to your nearest **AUTHORIZED SERVICE CENTER** for repair. When servicing, use only identical replacement parts.



### **WARNING:**

To avoid serious personal injury, do not attempt to use this product until you read thoroughly and understand completely the operator's manual. Save this operator's manual and review frequently for continuing safe operation and instructing others who may use this product.

---



### **WARNING:**



The operation of any power tool can result in foreign objects being thrown into your eyes, which can result in severe eye damage. Before beginning power tool operation, always wear safety goggles or safety glasses with side shields and a full face shield when needed. We recommend Wide Vision Safety Mask for use over eyeglasses or standard safety glasses with side shields. Always use eye protection which is marked to comply with ANSI Z87.1.

---

## SAVE THESE INSTRUCTIONS

# ELECTRICAL

## EXTENSION CORDS

Use only 3-wire extension cords that have 3-prong grounding plugs and 3-pole receptacles that accept the tool's plug. When using a power tool at a considerable distance from the power source, use an extension cord heavy enough to carry the current that the tool will draw. An undersized extension cord will cause a drop in line voltage, resulting in a loss of power and causing the motor to overheat. Use the chart provided below to determine the minimum wire size required in an extension cord. Only round jacketed cords listed by Underwriter's Laboratories (UL) should be used.

\*\*Ampere rating (on tool faceplate)

0-2.0    2.1-3.4    3.5-5.0    5.1-7.0    7.1-12.0    12.1-16.0

Cord Length	Wire Size (A.W.G.)					
25'	16	16	16	16	14	14
50'	16	16	16	14	14	12
100'	16	16	14	12	10	—

\*\*Used on 12 gauge - 20 amp circuit.

**NOTE:** AWG = American Wire Gauge

When working with the tool outdoors, use an extension cord that is designed for outside use. This is indicated by the letters "WA" on the cord's jacket.

Before using an extension cord, inspect it for loose or exposed wires and cut or worn insulation.

### **WARNING:**

Keep the extension cord clear of the working area. Position the cord so that it will not get caught on lumber, tools or other obstructions while you are working with a power tool. Failure to do so can result in serious personal injury.

### **WARNING:**

Check extension cords before each use. If damaged replace immediately. Never use tool with a damaged cord since touching the damaged area could cause electrical shock resulting in serious injury.

## ELECTRICAL CONNECTION

This tool is powered by a precision built electric motor. It should be connected to a **power supply that is 120 volts, 60 Hz, AC only (normal household current)**. Do not operate this tool on direct current (DC). A substantial voltage drop will cause a loss of power and the motor will overheat. If the saw does not operate when plugged into an outlet, double check the power supply.

## SPEED AND WIRING

The no-load speed of this tool is approximately 1,725 rpm. This speed is not constant and decreases under a load or with lower voltage. For voltage, the wiring in a shop is as important as the motor's horsepower rating. A line intended only for lights cannot properly carry a power tool motor. Wire that is heavy enough for a short distance will be too light for a greater distance. A line that can support one power tool may not be able to support two or three tools.

## GROUNDING INSTRUCTIONS

In the event of a malfunction or breakdown, grounding provides a path of least resistance for electric current to reduce the risk of electric shock. This tool is equipped with an electric cord having an equipment-grounding conductor and a grounding plug. The plug must be plugged into a matching outlet that is properly installed and grounded in accordance with all local codes and ordinances.

Do not modify the plug provided. If it will not fit the outlet, have the proper outlet installed by a qualified electrician. Improper connection of the equipment-grounding conductor can result in a risk of electric shock. The conductor with insulation having an outer surface that is green with or without yellow stripes is the equipment-grounding conductor. If repair or replacement of the electric cord or plug is necessary, do not connect the equipment-grounding conductor to a live terminal.

Check with a qualified electrician or service personnel if the grounding instructions are not completely understood, or if in doubt as to whether the tool is properly grounded.

Repair or replace a damaged or worn cord immediately.

This tool is intended for use on a circuit that has an outlet like the one shown in figure 1. It also has a grounding pin like the one shown.

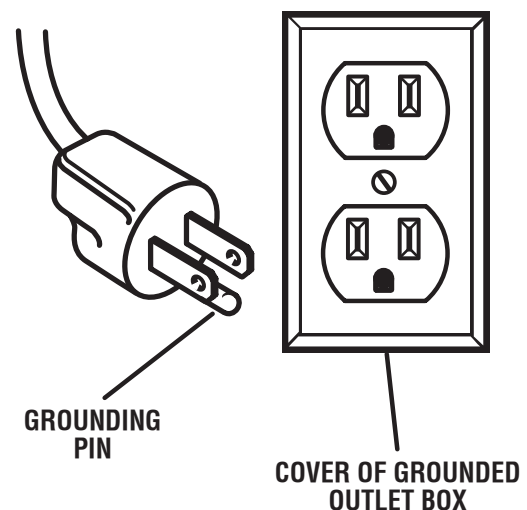

Fig. 1

# GLOSSARY OF TERMS

---

## **Anti-Kickback Pawls (radial arm and table saws)**

A device which, when properly installed and maintained, is designed to stop the workpiece from being kicked back toward the front of the saw during a ripping operation.

## **Arbor**

The shaft on which a blade or cutting tool is mounted.

## **Bevel Cut**

A cutting operation made with the blade at any angle other than 90° to the table surface.

## **Chamfer**

A cut removing a wedge from a block so the end (or part of the end) is angled rather than at 90°.

## **Compound Cut**

A cross cut made with both a miter and a bevel angle.

## **Crosscut**

A cutting or shaping operation made across the grain or the width of the workpiece.

## **Cutter Head (planers and jointers)**

A rotating piece of adjustable blades. The cutter head removes material from the workpiece.

## **Dado Cut**

A non-through cut which produces a square-sided notch or trough in the workpiece (requires a special blade).

## **Featherboard**

A device used to help control the workpiece by guiding it securely against the table or fence during any ripping operation.

## **FPM or SPM**

Feet per minute (or strokes per minute), used in reference to blade movement.

## **Freehand**

Performing a cut without the workpiece being guided by a fence, miter gauge, or other aids.

## **Gum**

A sticky, sap-based residue from wood products.

## **Heel**

Alignment of the blade to the fence.

## **Kerf**

The material removed by the blade in a through cut or the slot produced by the blade in a non-through or partial cut.

## **Kickback**

A hazard that can occur when the blade binds or stalls, throwing the workpiece back toward operator.

## **Leading End**

The end of the workpiece pushed into the tool first.

## **Miter Cut**

A cutting operation made with the workpiece at any angle to the blade other than 90°.

## **Non-Through Cuts**

Any cutting operation where the blade does not extend completely through the thickness of the workpiece.

## **Push Blocks and Push Sticks**

Devices used to feed the workpiece through the saw blade during cutting operations. A push stick (not a push block) should be used for narrow ripping operations. These aids help keep the operator's hands well away from the blade.

## **Pilot Hole (drill presses)**

A small hole drilled in a workpiece that serves as a guide for drilling large holes accurately.

## **Resaw**

A cutting operation to reduce the thickness of the workpiece to make thinner pieces.

## **Resin**

A sticky, sap-based substance that has hardened.

## **Revolutions Per Minute (RPM)**

The number of turns completed by a spinning object in one minute.

## **Ripping or Rip Cut**

A cutting operation along the length of the workpiece.

## **Riving Knife/Spreader/Splitter (table saws)**

A metal piece, slightly thinner than the blade, which helps keep the kerf open and also helps to prevent kickback.

## **Saw Blade Path**

The area over, under, behind, or in front of the blade. As it applies to the workpiece, that area which will be or has been cut by the blade.

## **Set**

The distance that the tip of the saw blade tooth is bent (or set) outward from the face of the blade.

## **Snipe (planers)**

Depression made at either end of a workpiece by cutter blades when the workpiece is not properly supported.

## **Throw-Back**

The throwing back of a workpiece usually caused by the workpiece being dropped into the blade or being placed inadvertently in contact with the blade.

## **Through Sawing**

Any cutting operation where the blade extends completely through the thickness of the workpiece.

## **Workpiece or Material**

The item on which the operation is being done.

## **Worktable**

Surface where the workpiece rests while performing a cutting, drilling, planing, or sanding operation.



# FEATURES

## PRODUCT SPECIFICATIONS

Motor ..... 3/8 HP Induction  
 Phase ..... Single  
 Rotation of Shaft ..... Clockwise  
 No Load Speed ..... 0-1725/rpm/spindle  
 No Load Speed ..... 0-1350/rpm/belt  
 Oscillation ..... 60/min.

Stroke ..... 3/4 in.  
 Sanding Sleeves ..... 1/2 in., 3/4 in., 1 in., 1-1/2 in., 2 in.  
 Sanding Drums ..... 3/4 in., 1 in., 1-1/2 in., 2 in.  
 Sanding Belt ..... 4 in. x 24 in.  
 Input ..... 120 V, 60 Hz, AC only, 5.0 Amps  
 Net Weight ..... 40 lbs.

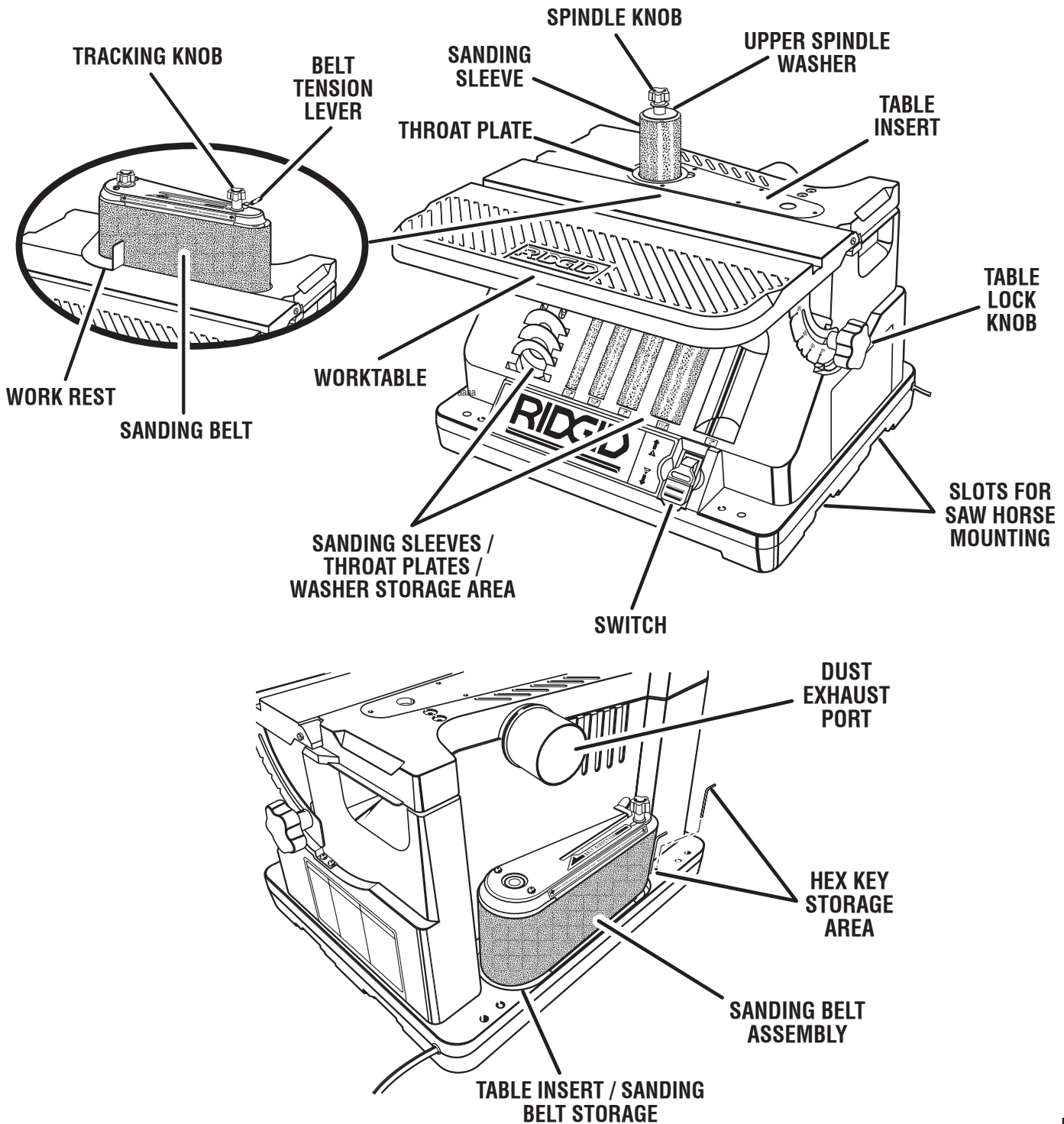

Fig. 2

# FEATURES

---

## KNOW YOUR OSCILLATING EDGE BELT/ SPINDLE SANDER

See Figure 2.

Before attempting to use this product, familiarize yourself with all operating features and safety rules.

### SANDING BELT

Removes material from wood. Oscillates (3/4 in.) up and down to sand faster and prevents burning of the workpiece.

### BELT TENSION LEVER

Slide lever left to release the sanding belt tension; slide right to apply belt tension.

### TRACKING KNOB

Turning knob counterclockwise causes sanding belt to move towards the table; turning knob clockwise causes sanding belt to move away from the table.

### SPINDLE KNOB

Loosen knob to remove sanding belt assembly (or sanding drum) and change to spindle sanding (or belt sanding).

**NOTE:** Knob has left hand threads. Turn knob clockwise to loosen and counterclockwise to tighten.

### WORK REST

Supports the workpiece on the sanding belt.

### THROAT PLATE

Fits around drum to help support workpiece.

### SANDING SLEEVE/DRUM

Removes material from wood. Oscillates up and down to sand faster and prevents burning the workpiece.

### TABLE LOCK KNOB

Loosening knob allows the front table to be tilted for bevel sanding.

### DUST EXHAUST PORT

2-1/2 in. opening for wet/dry vac hook-up.

### TABLE INSERT/SANDING BELT STORAGE

Holds table insert or sanding belt when not being used.

### TABLE INSERT

Helps to support workpiece when drum sanding.

### WORKTABLE

Equipped with a sturdy, worktable that provides a stable surface when using either the disc sanding or the belt sanding feature.

# TOOLS NEEDED

---

The following tools (not included) are needed for making adjustments to your tool:

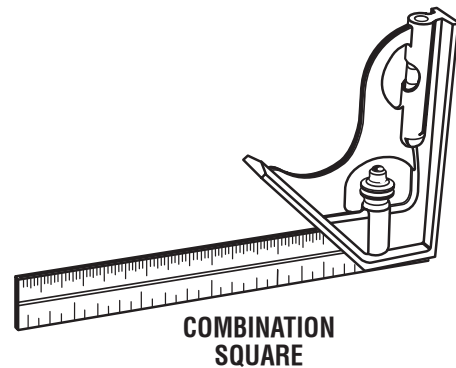

Fig. 3

# LOOSE PARTS

The following items are included with your tool:

- Oscillating Edge Belt/Spindle Sander (1)
- Throat Plates (4)
- Switch Key
- Hex Keys (2)
- Knob
- Rubber Feet (4)
- Flat Washers (4), 1-3/4 in. O.D., 7/8 in. O.D., 5/8 in. O.D., 1/2 in. I.D.
- Sanding Sleeves (5)
- Sanding Drums (4)
- Sanding Belt Assembly
- Table Insert
- Operator's Manual

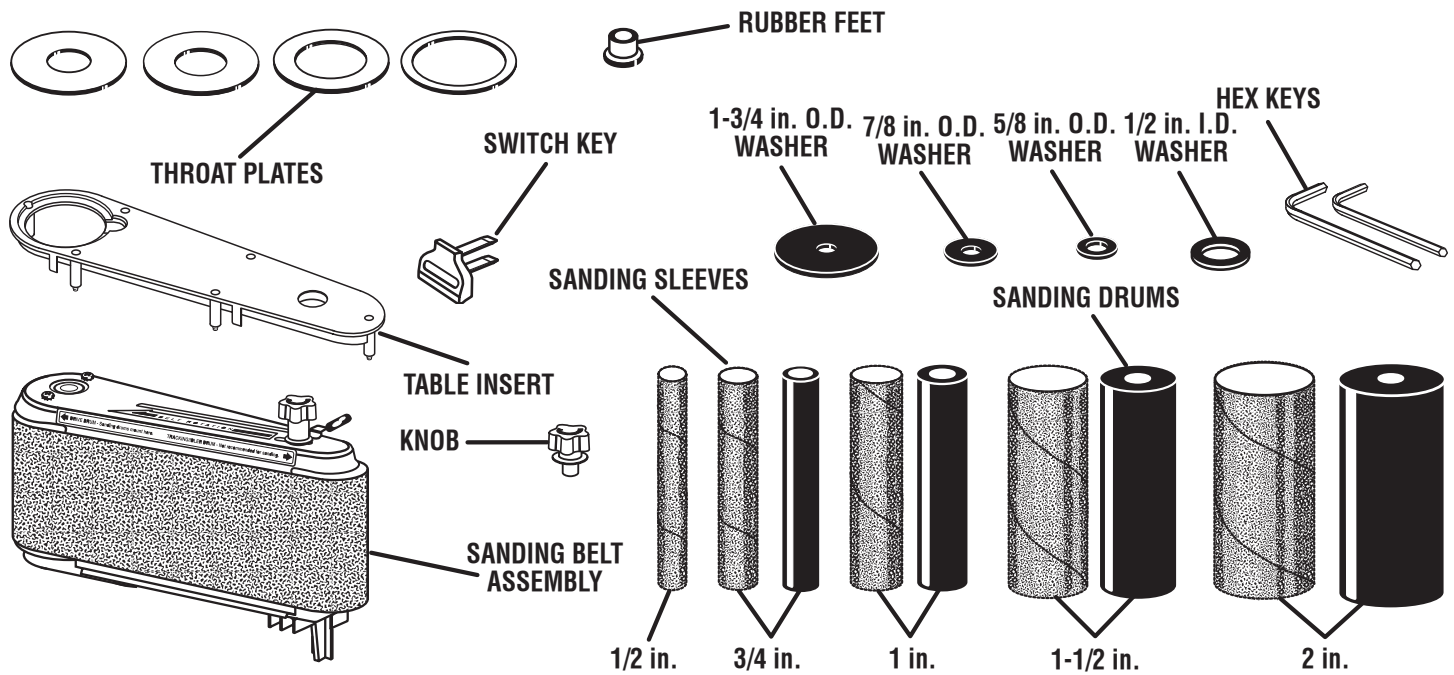

Fig. 4

## ⚠ WARNING:

The use of attachments or accessories not listed might be hazardous and could cause serious personal injury.

# ASSEMBLY

## UNPACKING

This product requires assembly.

- Carefully lift sander from the carton by the base, and place it on a level work surface.
  - NOTE:** This tool is heavy. To avoid back injury, lift with your legs, not your back, and get help when needed.
- Inspect the tool carefully to make sure no breakage or damage occurred during shipping.
- Do not discard the packing material until you have carefully inspected and satisfactorily operated the tool.
- If any parts are damaged or missing, please call 1-866-539-1710 for assistance.

## ⚠ WARNING:

If any parts are missing, do not operate this tool until the missing parts are replaced. Failure to do so could result in possible serious personal injury.

## ⚠ WARNING:

Do not attempt to modify this tool or create accessories not recommended for use with this tool. Any such alteration or modification is misuse and could result in a hazardous condition leading to possible serious personal injury.

# ASSEMBLY

## **⚠ WARNING:**

Do not connect to power supply until assembly is complete. Failure to comply could result in accidental starting and possible serious personal injury.

## **MOUNTING RUBBER FEET TO BASE**

See Figure 5.

- Place the sander directly on the table surface.
- From the parts bag locate the four rubber feet.
- Place the sander on its side so the bottom of the base is facing toward the front.
- Locate the four holes in each corner of the base and place one of the rubber feet in each of these holes.
- Position sander in the upright position and apply pressure in the downward position to ensure the feet are inserted securely.

## **⚠ CAUTION:**

To reduce the risk of injury from tool movement, the supporting surface where sander is mounted should be examined carefully after mounting to insure no movement during use can result. If any tipping or walking is noticed, secure to workbench or supporting surface before operating sander.

## **MOUNTING SANDER TO WORKBENCH**

See Figure 6.

If sander is to be used in a permanent location, it should be fastened securely to a firm supporting surface, such as a workbench, with either bolts or drywall screws.

### **Fastening with bolts**

- Use 1/4 in. bolts, washers, and nuts (not included). The bolt length should be 1-1/2 in. plus the thickness of the workbench.
- Locate and mark the holes where the sander is to be mounted.
- Drill four 3/8 in. diameter holes through workbench.
- Place sander on workbench, aligning holes in base with holes drilled in workbench.
- Insert four 1/4 in. diameter bolts and washers and attach nuts securely.

### **Fastening with screws**

- Drive four 2-1/2 in. long screws through the holes in the base and through the workbench. Do not overtighten the screws.

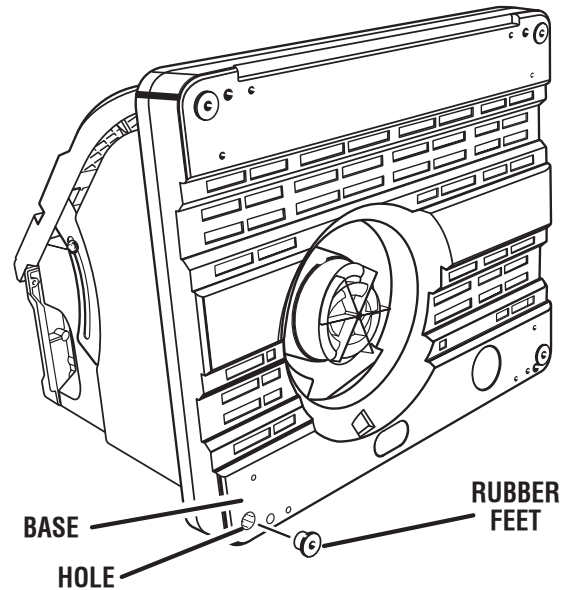

Fig. 5

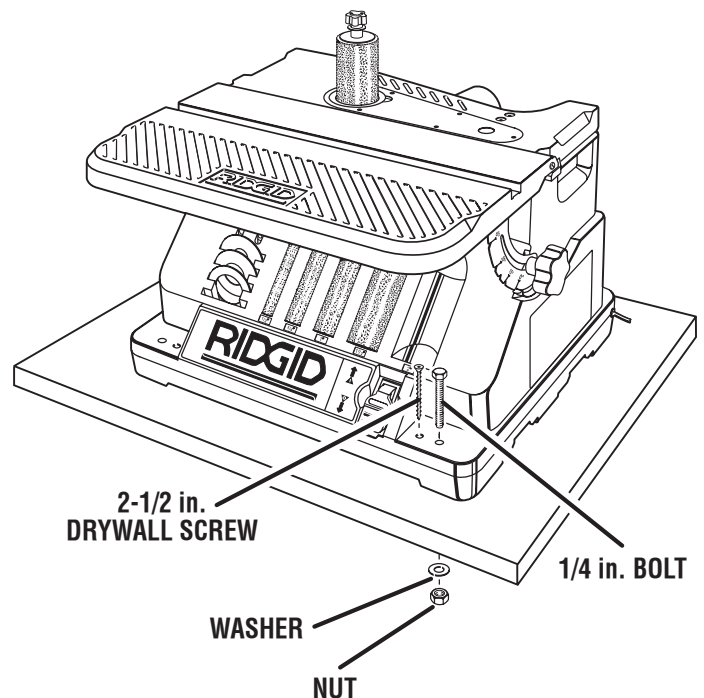

Fig. 6

# ASSEMBLY

## CLAMPING SANDER TO WORKBENCH

See Figure 7.

An alternative method of mounting is to fasten the sander to a mounting board. The board should be sufficient size to avoid tipping while in use. Any good grade of plywood or chipboard with a 3/4 in. thickness is recommended. (Thinner chipboard can break.)

Once sander is mounted to board, clamp to workbench.

**NOTE:** For proper stability, holes must be countersunk so screw heads are flush with the surface of supporting board.

## SUPPORTING OSCILLATING EDGE BELT/ SPINDLE SANDER TO SAWHORSES

See Figure 8.

The sander has provisions for being supported by sawhorses. The sawhorse can be built with the crosspiece either vertical or horizontal. Make sure the sawhorses are secure.

## PARTS STORAGE

See Figures 9 - 10.

On board storage has been provided for all washers, spacers, drums, sleeves and hex keys. All front loaded parts can be protected from incidental dislodging by lowering the table all the way down until it rests against the base and tightening the knob.

Storage for the sanding belt assembly is provided in the pocket on the rear of the base.

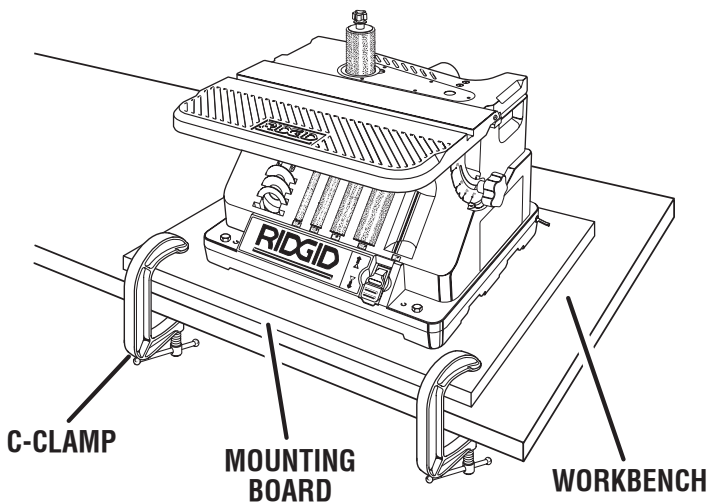

Fig. 7

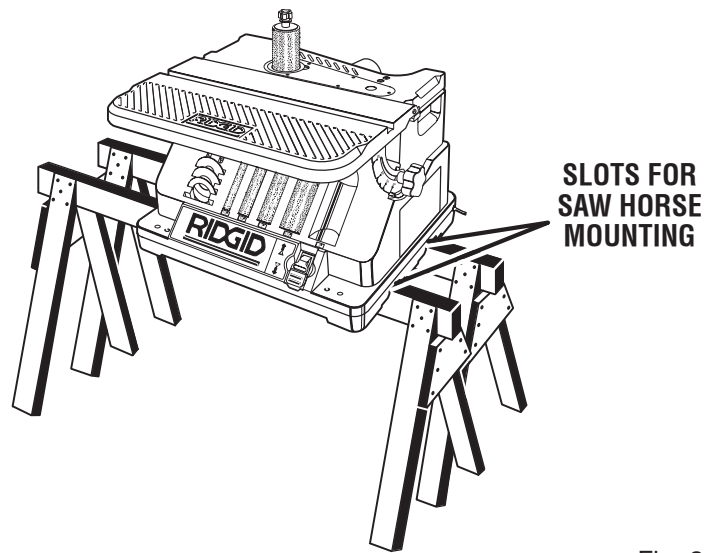

Fig. 8

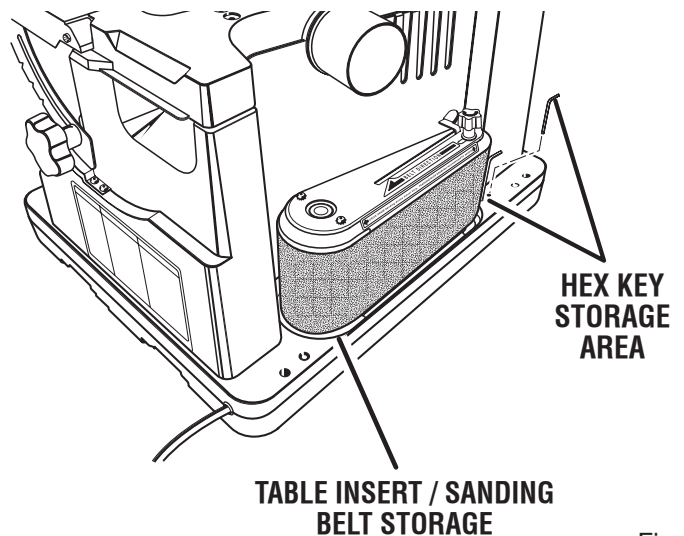

Fig. 9

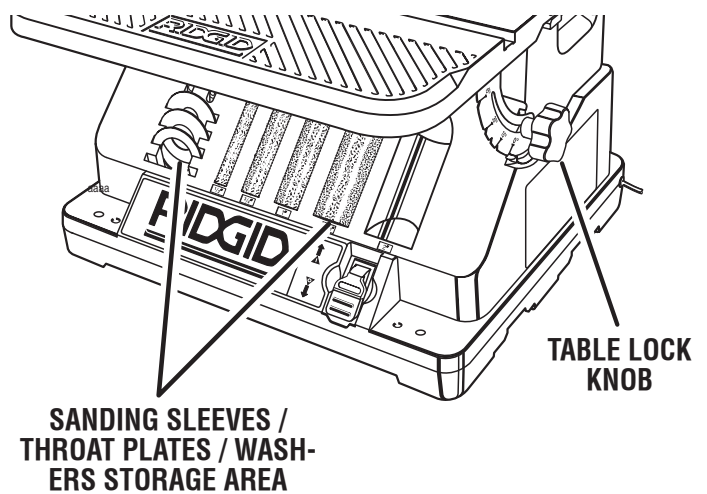

Fig. 10

# ASSEMBLY

## INSTALLING THE SANDING BELT ASSEMBLY

See Figure 11.

- Remove the fan and clean sawdust from inside table recess.
- Slide the fan onto the motor shaft (vanes face down) aligning slot with roll pin as shown. **The fan is used in all sanding operations.**
- Slide belt assembly down motor shaft. Align drive drum splines with the slots in the fan. Place belt assembly into the wear plate opening as shown.
- Tighten spindle knob. Do not overtighten.  
**NOTE:** Knob turns counterclockwise to tighten.
- Install sanding belt (see “Removing/Installing the Sanding Belt”, page 21).
- Plug the power cord into the power source and install the key.

## REMOVING THE SANDING BELT ASSEMBLY

See Figure 12.

- Loosen the work rest knob and pivot the work rest out of the way. Tighten the work rest knob.
- Remove the spindle knob and lift off the sanding belt assembly.
- **NOTE:** Knob turns clockwise to loosen.
- Store assembly in pocket in rear of base.

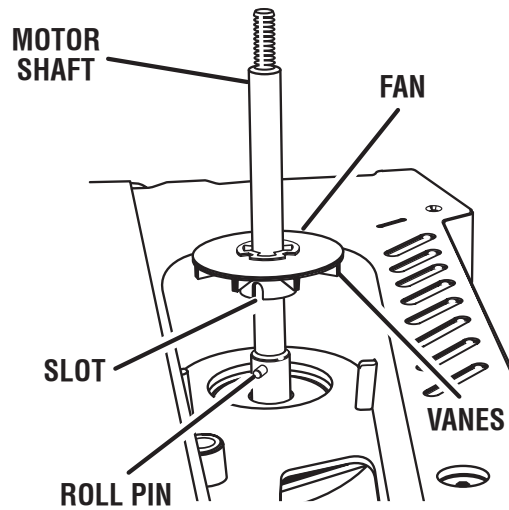

Fig. 11

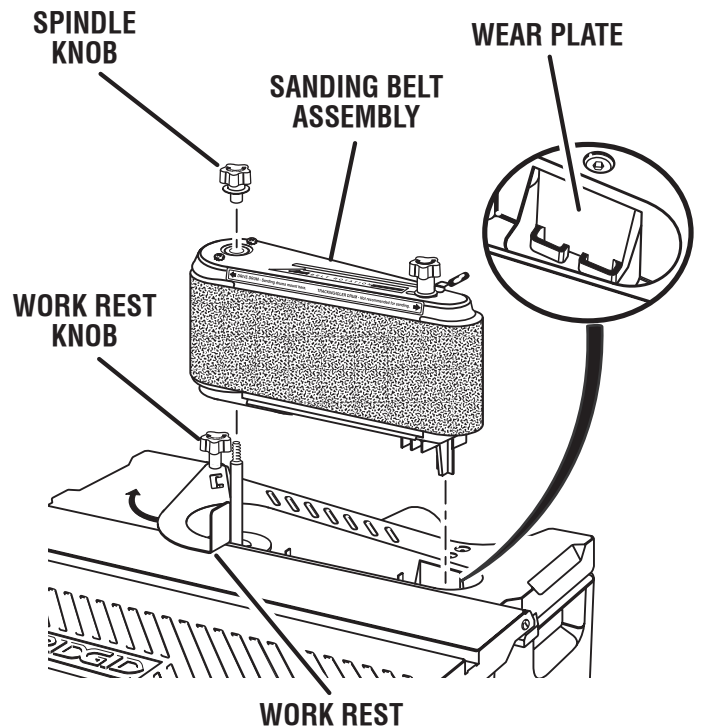
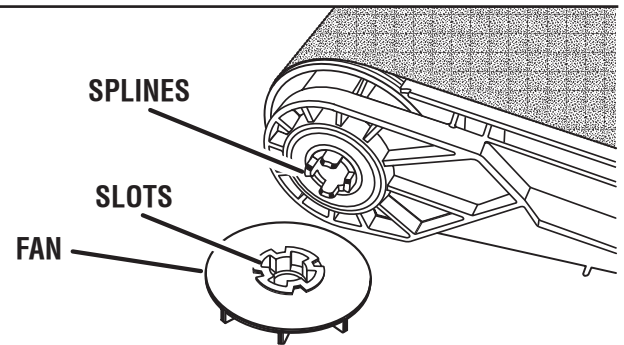

Fig. 12

# ASSEMBLY

## INSTALLING SANDING SLEEVES LARGER THAN 1/2 IN. DIAMETER

See Figures 13 - 14.

- Remove the fan and clean sawdust from inside table recess.
- Slide the fan onto the motor shaft (vanes face down) aligning slot with roll pin. **The fan is used with all drums and sleeves.**
- Install the table insert by sliding it over the fan.
- Use a straight edge as shown to make sure the table insert is flush with the table.
- If necessary, adjust the set screws in the table insert with the 3/32 in. hex key provided.
- Slide the sanding sleeve-rubber drum onto the spindle.  
**NOTE:** If the drum is difficult to slide over the spindle, apply talcum powder to the spindle.
- Position throat plate insert in the table recess. (See recommended throat plate insert selection area from table on page 16). Use the smallest throat plate insert that will fit over the drum.
- Place desired sanding sleeve on correct drum.  
**NOTE:** If the sanding sleeve is difficult to slide over the drum, apply talcum powder to the outside surface of the rubber drum.
- Install the correct upper spindle washer and tighten the knob. Do not overtighten.  
**NOTE:** Knob turns counterclockwise to tighten.
- Plug power cord in the power source and install the switch key.

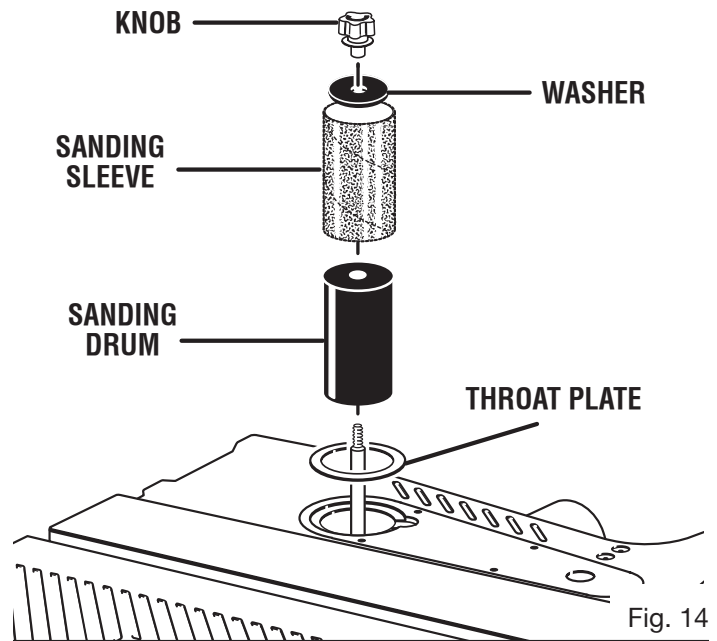
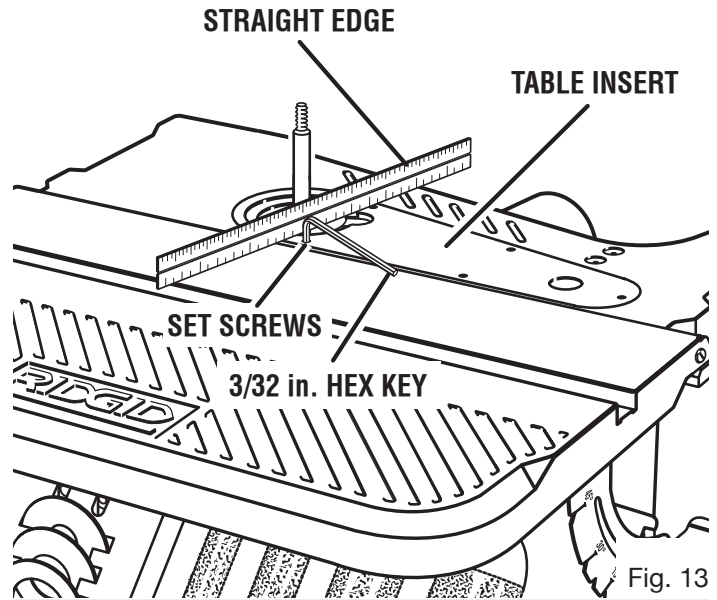

# ASSEMBLY

## INSTALLING SANDING SLEEVES FOR THE 1/2 IN. DIAMETER SANDING DRUM

See Figure 15.

- Remove the fan and clean sawdust from inside table recess.
- Slide the fan onto the motor shaft (vanes face down) aligning slot with roll pin. **The fan is used with all sanding operations.**
- Install 1/2 in. I.D. washer over motor shaft.
- Install the throat plate.
- Use a straight edge as shown to make sure the table insert is flush with the table. If necessary, adjust the set screws in the table insert with the 3/32 in. hex "L" wrench provided.

Sanding Sleeve Diameter	Throat plate Insert Opening Inside Diameter (I.D.)	Upper Spindle Washer Outside Diameter (O.D.)
1/2 in.	15/16 in.	5/8 in.
3/4 in.		
1 in.	1-3/16 in.	7/8 in.
1-1/2 in.	1-11/16 in.	
2 in.	2-3/16 in.	1-3/4 in.

- Position 15/16 in. I.D. throat plate into the table recess.
- Locate 1/2 in. sanding sleeve and slide it on the spindle. **(Rubber drum is not used.)**
- Install the upper spindle washer and tighten the knob. **Do not overtighten.**

**NOTE:** Knob turns counterclockwise to tighten.

- Plug power cord into the power source and install the yellow switch key.

## SELECTION OF THROAT PLATE INSERTS AND UPPER SPINDLE WASHERS

See Figure 16.

### **WARNING:**

Using the wrong throat plate throat plate may permit small pieces of wood or finger tips to become wedged between the abrasive surface and the insert.

**NOTE:** Use the smallest throat plate that will fit over the drum.

**NOTE:** Use the largest upper spindle washer that will not protrude past sanding sleeve.

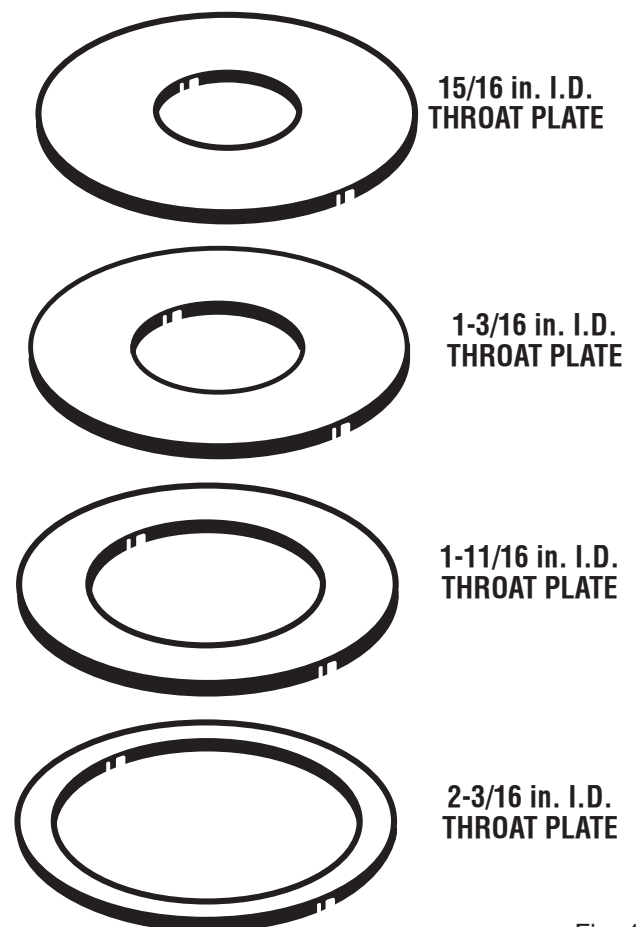
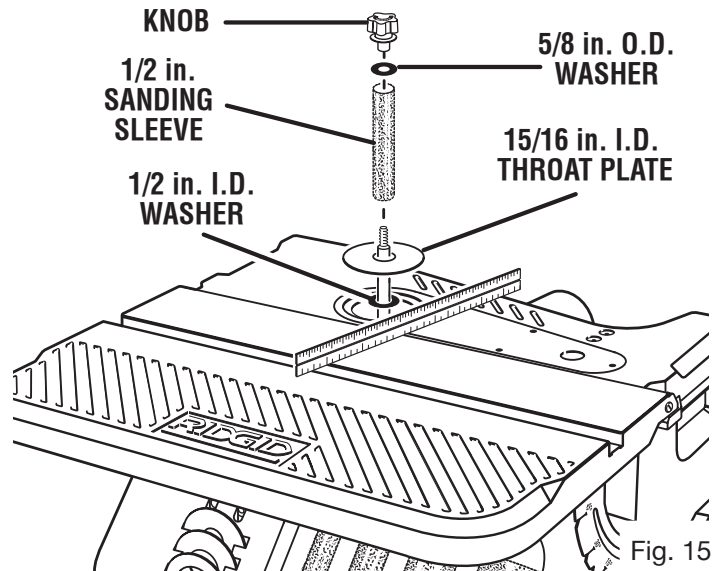

Fig. 16



# OPERATION

## **WARNING:**

Do not allow familiarity with your tool to make you careless. Remember that a careless fraction of a second is sufficient to inflict severe injury.

## **WARNING:**

Always wear safety goggles or safety glasses with side shields when operating tools. Failure to do so could result in objects being thrown into your eyes, resulting in possible serious injury.

## APPLICATIONS

This product has been designed only for the purposes listed below:

- Oscillating and Rotary Motion – for fast, burn free finishes on edges, faces, contours, inside and outside curves.

## ON-OFF SWITCH

See Figure 17.

## **WARNING:**

Always remove the switch key when the tool is not in use and keep it in a safe place. In the event of a power failure, turn the switch OFF (O) and remove the key. This action will prevent the tool from accidentally starting when power returns.

The ON-OFF switch has a locking feature. This feature is intended to help prevent unauthorized and possible hazardous use by children and others.

- To turn sander ON ( I ) insert key into switch.
- Lift the switch button to turn on.
- To turn sander OFF ( O ). Push lever in.
- To lock switch in OFF ( O ) position, hold switch in with one hand. Remove key with other hand.

## **CAUTION:**

Before turning switch on, make sure the belt or drum and sleeve are properly installed.

### TO TURN ON

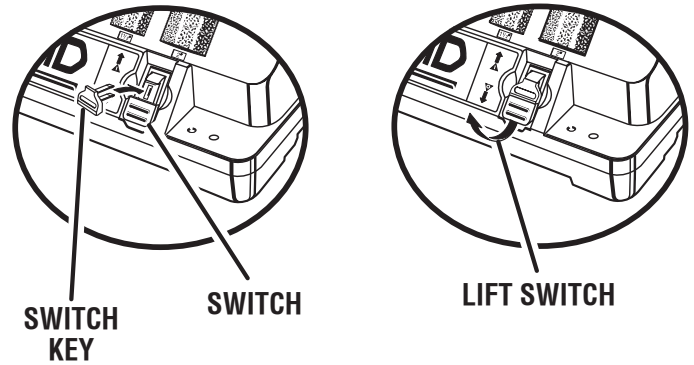

### TO TURN OFF

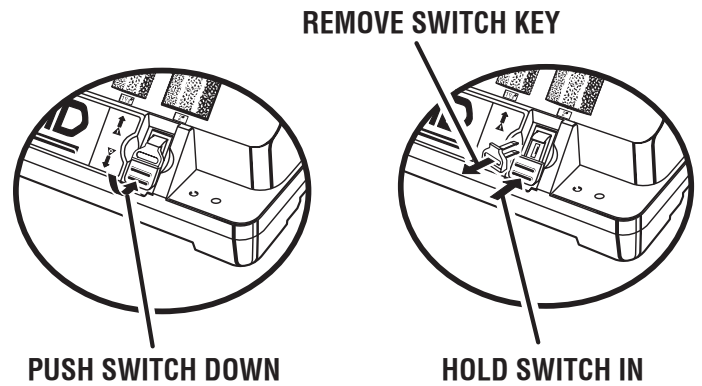

Fig. 17

## WHEN SANDER IS RUNNING

Before starting your work, watch the sander while it runs. If it makes an unfamiliar noise or vibrates excessively, stop immediately. Turn the sander off. Unplug the sander. Do not restart until identifying and correcting the problem.

Before using the sander, make sure the sanding belt turns clockwise, when viewed from above.

Don't force tool. It will perform better and safer at its designed rate. Press workpiece against the sanding sleeve or belt hard enough to begin sanding without bogging down or binding spindle.

## BEFORE FREEING ANY JAMMED MATERIAL:

- Turn switch OFF ( O ).
- Unplug the sander.
- Wait for all moving parts to stop.

## BEFORE LEAVING THE SANDER

- Turn switch off. Don't leave tool until the unit comes to a complete stop.

Make workshop childproof. Remove the switch key. Store it away from children and others not qualified to use the tool. Disconnect master switches. Lock the shop.

# OPERATION

## PRECAUTIONS TO TAKE WHEN SANDING METALS

When sanding metals, sparks or hot fragments could cause a fire. To reduce the risk of this:

- Disconnect any dust collecting hose from the sander.
- Remove all traces of wood dust from inside the unit before sanding metals.
- Remove all traces of metal dust from inside the unit before sanding wood again.

## PRECAUTIONS TO TAKE WHEN SANDING PAINT

Sanding of lead-based paint is not recommended. It is difficult to control the contaminated dust that could cause lead poisoning.

It is also difficult to identify whether or not a paint contains lead. Therefore, we recommend the following precautions when sanding all paints:

- Protect your lungs. Wear a dust mask or respirator at all times. Wear only dust masks that are suitable for working in lead paint sanding environments. Ordinary painting masks do not offer this protection.
- Do not allow children or pregnant women to enter the work area until paint sanding job is complete and work area is clean.
- To prevent ingesting contaminated paint particles: Do not eat, drink, or smoke in a work area where paint is being sanded. After sanding paint, wash and clean up before eating, drinking or smoking. Do not leave food, drinks, or tobacco products in the work area where dust can settle on them.

## BASIC SANDING OPERATION

### Sandpaper selection

Selecting the correct size diameter, correct size grit, and correct type sandpaper is an extremely important step in achieving a high quality sanded finish. Aluminum oxide, silicon carbide, and other synthetic abrasives are best for power sanding. Natural abrasives, such as flint and garnet, are too soft for economical use in power sanding.

In general, coarse grit will remove the most material and finer grit will produce the best finish in all sanding operations. The condition of the surface to be sanded will determine which grit will do the job. If the surface is rough, start with a coarse grit and sand until the surface is uniform. Medium grit may then be used to remove scratches left by the coarser grit and finer grit used for finishing of the surface. Always continue sanding with each grit until surface is uniform.

**NOTE:** Do not use sander without sandpaper. Doing so will damage the rubber drum.

Select and install the desired sanding sleeve for the particular application. Sanding sleeves from 1/2 in. to 2 in. can be used with this sander. Choose one that is close in size to the workpiece you are sanding. Also install the appropriate throat plate insert (page 16).

### **⚠ WARNING:**

Failure to use the correct size throat plate insert with its matching sanding sleeve could result in fingers being pinched or the workpiece being pulled down between the throat plate insert and sanding sleeve.

**NOTE:** The correct size sanding belt is 4 in. x 24 in. These belts are available in coarse, medium and fine grits.

## SURFACE SANDING ON THE SANDING BELT

See Figure 18.

### **⚠ WARNING:**

To reduce the risk of injury from slips, jams or thrown pieces, adjust the work rest to clear the sanding surface by no more than 1/16 of an inch. When checking clearance between the sanding belt and work rest, press the sanding belt flat against the metal worktable beneath it.

- Hold the workpiece firmly with both hands, keeping fingers away from the sanding belt.
- Keep the end butted against the work rest and move the work evenly across the sanding belt. Use caution when sanding very thin pieces.
- For sanding long pieces the work rest can be rotated out of the way.
- Apply only enough pressure to allow the sanding belt to remove material.
- Do not sand thin pieces that may become trapped between the belt and work rest.

### SURFACE SANDING

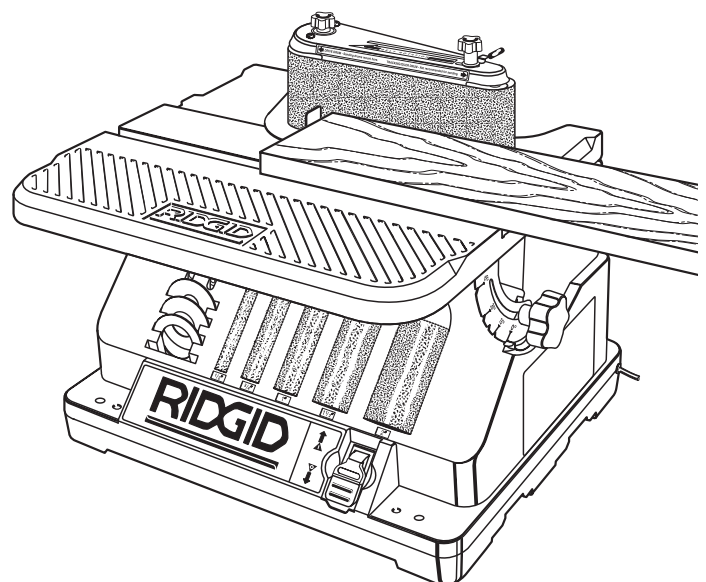

Fig. 18

# OPERATION

## END SANDING ON THE SANDING BELT

See Figure 19.

- Move the work evenly across the sanding belt. For accuracy, use a miter gauge accessory (not included).

## SANDING CURVED EDGES

See Figure 20.

Inside curves are best sanded with the sander assembled in the spindle mode. However, inside curves larger than 1-1/2 in. may be sanded on the drive drum when in the belt sander mode.

Although it is possible to lightly sand on the idler drum end of the belt sanding assembly, it is not recommended. The idler drum is an integral part of the belt tracking mechanism. It is spring loaded to maintain proper tension. Use of the idler drum to sand curves may cause belt to track improperly.

## FEED DIRECTION

See Figure 21.

### WARNING:

To prevent thrown workpiece, feed workpiece against sanding sleeve from left to right as shown.

The sanding sleeve rotates clockwise. Feed the workpiece against the sanding sleeve from left to right as shown. When fed from left to right, the rotation of the sanding sleeve sands against the workpiece. If fed in the opposite direction, the rotation forces of the spinning sanding sleeve will tend to throw or bounce the workpiece away from the sanding sleeve. This could cause loss of control of workpiece or possible injury.

END SANDING

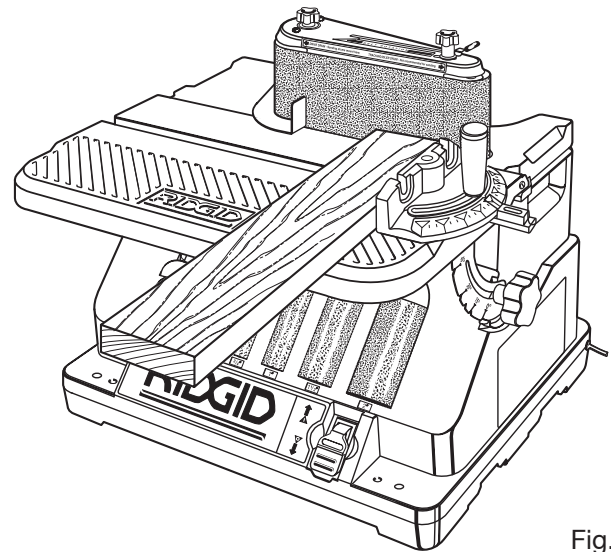

Fig. 19

CURVED EDGE SANDING

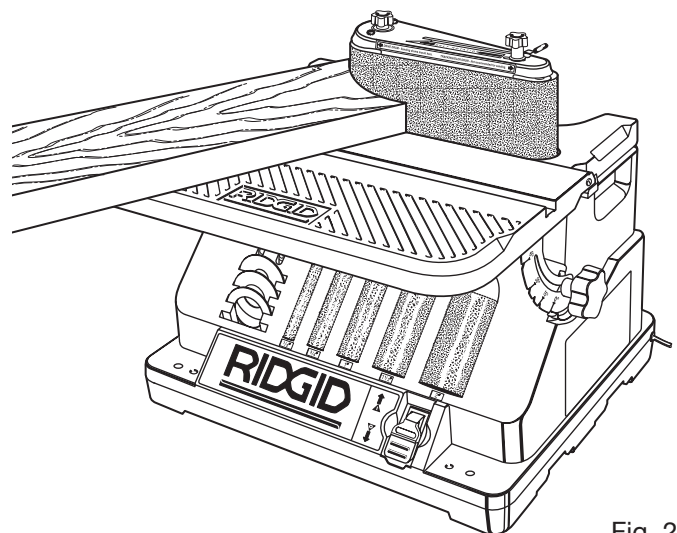

Fig. 20

 FEED DIRECTION

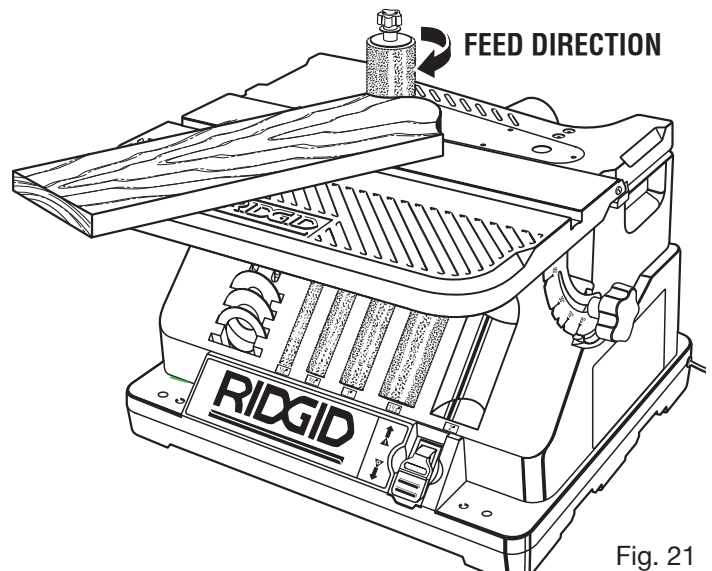

Fig. 21

# ADJUSTMENTS

## **⚠ WARNING:**

Before performing any adjustment, make sure the tool is unplugged from the power supply and the switch is in the OFF (O) position. Failure to heed this warning could result in serious personal injury.

## **SQUARING FRONT TABLE**

See Figure 22.

**NOTE:** Use a combination square to check the angle of the front table with the sanding belt.

### **If the front table is not 90° to the sanding belt:**

- Use the hex key provided and “back out” both set screws located on each side of the table.
- Loosen the front table lock knob and adjust the front table 90° to the sanding belt.
- Tighten the front table lock knob.
- Adjust both set screws to contact the front table.
- Adjust detent if necessary
- Loosen the two pan head screws that secure the detent.
- Adjust detent so that it engages the notches in the bracket table lock.
- Tighten the two pan head screws.

## **ALIGNING BELT TO MITER GAUGE SLOT**

See Figure 23.

The sanding belt is installed at the factory; however, check and make sure the belt is parallel to the miter gauge groove: Use a combination square to check the distance from the miter gauge groove to the belt assembly as shown.

- If adjustment is required, use a 5/32 in. hex key provided with unit to loosen the two flat head socket recess screws on the table.
- Adjust the worktable as needed to make it parallel or same distance to the miter gauge slot.
- Tighten two screws.

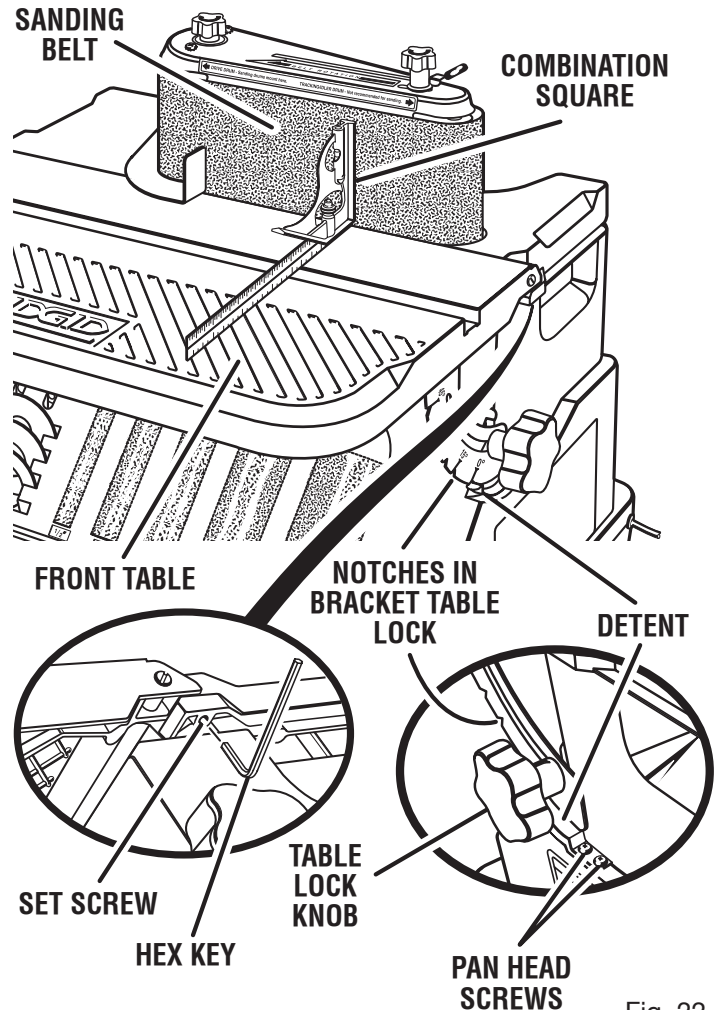

Fig. 22

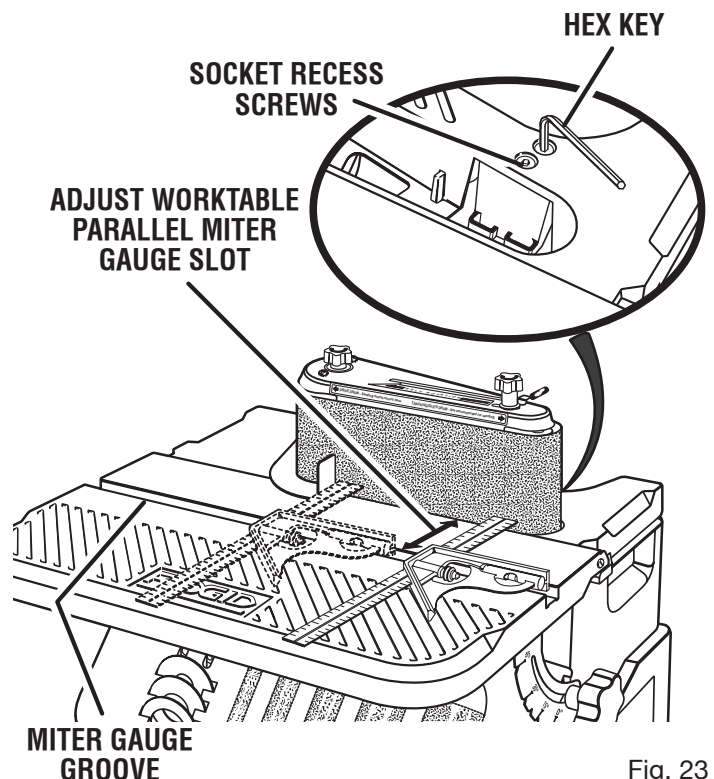

Fig. 23

# ADJUSTMENTS

## REMOVING/INSTALLING THE SANDING BELT

See Figures 24 - 26.

### Tensioning and Tracking

Some sanding belts have a “directional arrow” on the inside or smooth side. If there is an arrow, the belt must run in the direction of the arrow so the splice will not come apart. If there is no arrow the belt may be put on either direction.

- Slide the tension lever to the left to release the belt tension.
- Remove the sanding belt.
- Place the replacement sanding belt over the drums as shown. Make sure the belt is centered on both drums.
- Slide the tension lever to the right to apply belt tension.
- Plug in the power cord. Insert the switch key and turn the unit ON (I) and immediately OFF (O), noting if the belt tends to slide off the drums. If it did not tend to slide off, it is tracking properly.
- If the sanding belt runs down towards the table, turn the tracking knob clockwise 1/4 turn.
- If the sanding belt, runs up away from the table, turn the tracking knob counterclockwise 1/4 turn.
- Turn switch ON (I) and immediately OFF (O) again, noting belt movement. Readjust tracking knob if necessary.

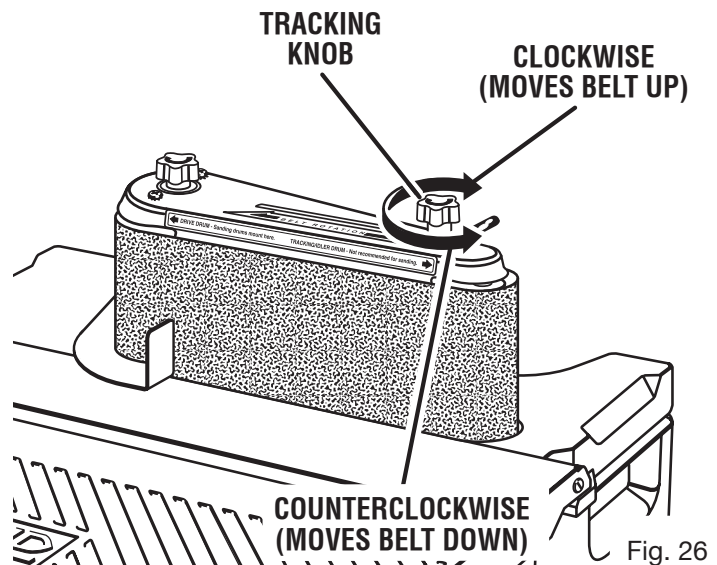
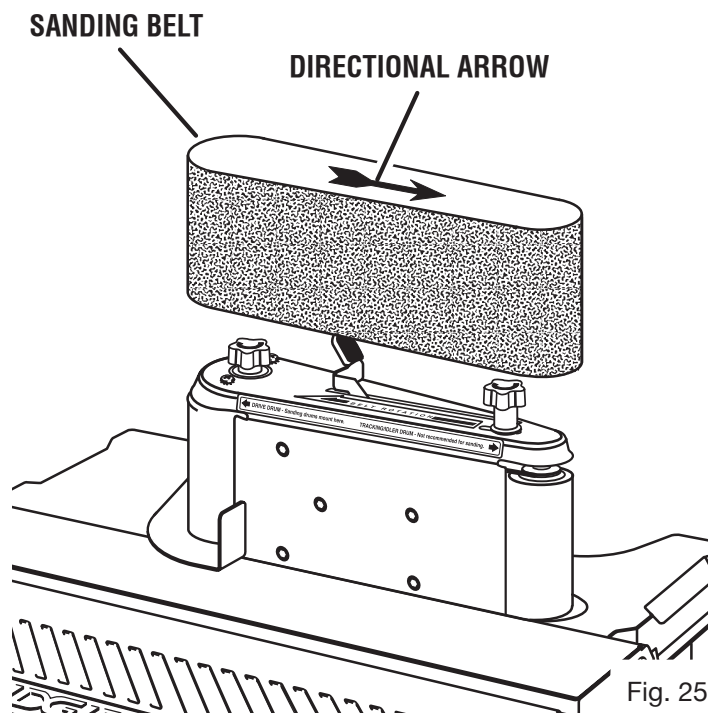
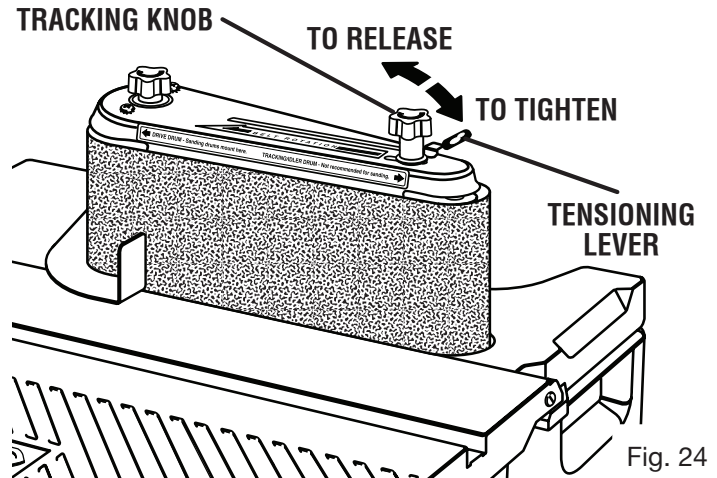

# MAINTENANCE

## **WARNING:**

When servicing use only identical RIDGID replacement parts. Use of any other parts may create a hazard or cause product damage.

## **WARNING:**

Always wear safety goggles or safety glasses with side shields during power tool operation or when blowing dust. If operation is dusty, also wear a dust mask.

## GENERAL MAINTENANCE

Avoid using solvents when cleaning plastic parts. Most plastics are susceptible to damage from various types of commercial solvents and may be damaged by their use. Use clean cloths to remove dirt, dust, oil, grease, etc.

## **WARNING:**

Do not at any time let brake fluids, gasoline, petroleum-based products, penetrating oils, etc., come in contact with plastic parts. Chemicals can damage, weaken or destroy plastic which may result in serious personal injury.

Electric tools used on fiberglass material, wallboard, spackling compounds, or plaster are subject to accelerated wear and possible premature failure because the fiberglass chips and grindings are highly abrasive to bearings, brushes, commutators, etc. Consequently, it is not recommended using this tool for extended work on these types of materials. However, if you do work with any of these materials, it is extremely important to clean the tool using compressed air.

## LUBRICATION

All of the bearings in this tool are lubricated with a sufficient amount of high grade lubricant for the life of the unit under normal operating conditions. Therefore, no further lubrication is required.

## DUST COLLECTION CAPABILITY

See Figure 27.

A standard 2-1/2 in. dust exhaust port has been provided to make dustless sanding possible. It is on the rear of the sander as shown. The pickup adapter end of a vacuum hose fits inside the dust exhaust port with a wedge fit.

Even with a dust collection system, it is necessary to periodically clean sanding dust from the recess in the table. Sawdust buildup in the table recess may prevent the belt or spindle from making a complete oscillation, which may cause premature wear.

## TRANSPORTING SANDER

When using the sander in a portable application, it is acceptable to lift and carry sander by the worktable or by the carry handles. Be careful when transporting to reduce the risk of dislodging accessories, throat plate inserts, wrench, and upper spindle washers from their respective storage areas.

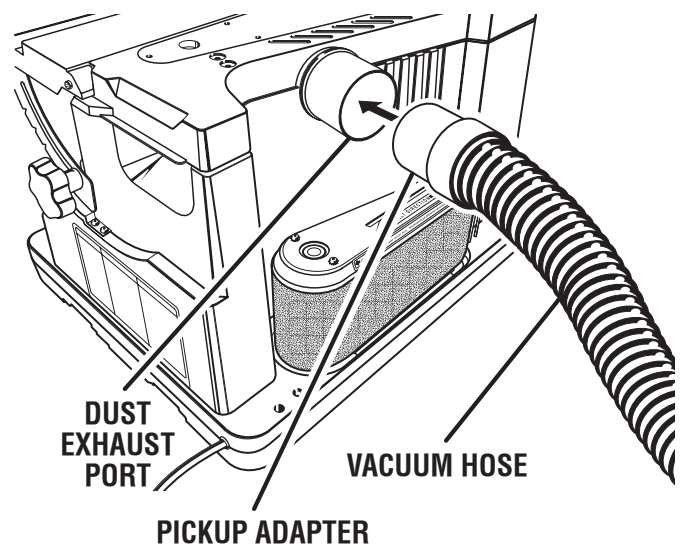

Fig. 27

# ACCESSORIES

---

The following recommended accessories are currently available at Home Depot stores:

- Miter Gauge..... AC1021
- Switch Key ..... AC1000
- Universal Legset..... AC9910
- Replacement Sanding Sleeves, 2 pk. See Chart Below

Size	Grit	SKU No.
1/2 in.	Fine	AC7001
	Medium	AC7002
3/4 in.	Coarse	AC7003
	Fine	AC7004
1 in.	Medium	AC7005
	Coarse	AC7006
1-1/2 in.	Fine	AC7007
	Medium	AC7008
	Coarse	AC7009
2 in.	Fine	AC7010
	Medium	AC7011
	Coarse	AC7012
	Fine	AC7013
	Medium	AC7014
	Coarse	AC7015

Do not use any accessory unless you have received and read complete instructions for its use.

**NOTE:** 4 in. x 24 in. replacement sanding belts are available at your local Home Depot store.

---

 **WARNING:**

Current attachments and accessories available for use with this tool are listed above. Do not use any attachments or accessories not recommended by the manufacturer of this tool. The use of attachments or accessories not recommended can result in serious personal injury.

---

# TROUBLESHOOTING

Problem	Cause	Solution
Excessive noise <b>NOTE:</b> The sander will make some noise when it is operating normally	1. Motor gearbox not operating correctly.	1. Consult Authorized Service Center; any attempt to repair this motor or gearbox may create a hazard unless repair is done by a qualified service technician.
Motor fails to develop full power, starts slowly, or fails to come up to full speed. <b>NOTE:</b> Low voltage	1. Circuit overloaded with lights, appliances and other motor. 2. General overloading of power company facilities. 3. Motor relay not operating.	1. Do not use sander on heavily loaded circuits. 2. Request a voltage check by qualified electrician. 3. Have relay replaced. Consult Authorized Service Center. Any attempt to repair this relay may create a hazard unless repair is done by a qualified service technician.
Motor overheats	1. Motor overloaded.	1. Reduce pressure on workpiece.
Motor stalls (resulting in blown fuses or circuit breakers)	1. Motor relay not operating. 2. Voltage too low. Circuit overloaded or general overloading of power company facilities. 3. Incorrect fuses or circuit breakers in power line.	1. Have relay replaced. Consult Authorized Service Center. Any attempt to repair this relay may create a hazard unless repair is done by a qualified service technician. 2. Request voltage check by qualified electrician. 3. Install correct fuse or circuit breaker.
Frequent opening of fuse or circuit breaker	1. Motor overloaded. 2. Incorrect fuses or circuit breaker in power line. 3. Relay not operating.	1. Feed work slower. 2. Install correct fuse or circuit breakers. 3. Have relay replaced. Consult Authorized Service Center. Any attempt to repair this relay may create a hazard unless repair is done by a qualified service technician.
Motor will not run	1. Damaged On-Off Switch/Cord. 2. Burned out motor, no power to motor or low voltage.	1. Replace damaged parts before using sander. 2. Consult Authorized Service Center. Any attempt to repair this motor may create a hazard unless repair is done by a qualified service technician.
Sanding drum or belt slips or slows down easily	1. Applying too much pressure to workpiece. 2. Spindle knob too loose.	1. Ease up on workpiece. 2. Tighten spindle knob.
Wood burns while sanding	1. Sanding drum is glazed with sap.	1. Replace sandpaper.
Sandpaper doesn't remove material	1. Sandpaper is compacted with sawdust.	1. Replace sandpaper.
Spindle doesn't go through full 3/4 in. travel	1. Sawdust is compacted under lower drum washer. 2. Fan not installed. 3. Damaged gearbox.	1. Vacuum sawdust from area of lower drum washer. 2. Ensure that fan is installed with vanes face down. 3. Consult Authorized Service Center. Any attempt to repair this gearbox may create a hazard unless repair is done by a qualified service technician.



# WARRANTY

---

## RIDGID® HAND HELD AND STATIONARY POWER TOOL 3 YEAR LIMITED SERVICE WARRANTY

Proof of purchase must be presented when requesting warranty service.

Limited to RIDGID® hand held and stationary power tools purchased 2/1/04 and after. This product is manufactured by TTI Consumer Power Tools, Inc. The trademark is licensed from RIDGID, Inc. All warranty communications should be directed to TTI Consumer Power Tools, Inc., attn: RIDGID Hand Held and Stationary Power Tool Technical Service at (toll free) 1-866-539-1710.

### 90-DAY SATISFACTION GUARANTEE POLICY

During the first 90 days after the date of purchase, if you are dissatisfied with the performance of this RIDGID® Hand Held and Stationary Power Tool for any reason you may return the tool to the dealer from which it was purchased for a full refund or exchange. To receive a replacement tool you must present proof of purchase and return all original equipment packaged with the original product. The replacement tool will be covered by the limited warranty for the balance of the 3 YEAR service warranty period.

### WHAT IS COVERED UNDER THE 3 YEAR LIMITED SERVICE WARRANTY

This warranty on RIDGID® Hand Held and Stationary Power Tools covers all defects in workmanship or materials and normal wear items such as brushes, chucks, motors, switches, cords, gears and even cordless batteries in this RIDGID® tool for three years following the purchase date of the tool. Warranties for other RIDGID® products may vary.

### HOW TO OBTAIN SERVICE

To obtain service for this RIDGID® tool you must return it; freight prepaid, or take it in to an authorized service center for RIDGID® branded hand held and stationary power tools. You may obtain the location of the authorized service center nearest you by calling (toll free) 1-866-539-1710 or by logging on to the RIDGID® website at [www.ridgid.com](http://www.ridgid.com). When requesting warranty service, you must present the original dated sales receipt. The authorized service center will repair any faulty workmanship, and either repair or replace any part covered under the warranty, at our option, at no charge to you.

### WHAT IS NOT COVERED

This warranty applies only to the original purchaser at retail and may not be transferred. This warranty only covers defects arising under normal usage and does not cover any malfunction, failure or defect resulting from misuse, abuse, neglect, alteration, modification or repair by other than an authorized service center for RIDGID® branded hand held and stationary power tools. Consumable accessories provided with the tool such as, but not limited to, blades, bits and sand paper are not covered.

**RIDGID, INC. AND TTI CONSUMER POWER TOOLS, INC. MAKE NO WARRANTIES, REPRESENTATIONS OR PROMISES AS TO THE QUALITY OR PERFORMANCE OF ITS POWER TOOLS OTHER THAN THOSE SPECIFICALLY STATED IN THIS WARRANTY.**

### ADDITIONAL LIMITATIONS

To the extent permitted by applicable law, all implied warranties, including warranties of MERCHANTABILITY or FITNESS FOR A PARTICULAR PURPOSE, are disclaimed. Any implied warranties, including warranties of merchantability or fitness for a particular purpose, that cannot be disclaimed under state law are limited to three years from the date of purchase. TTI Consumer Power Tools, Inc. and RIDGID, Inc. are not responsible for direct, indirect, incidental or consequential damages. Some states do not allow limitations on how long an implied warranty lasts and/or do not allow the exclusion or limitation of incidental or consequential damages, so the above limitations may not apply to you. This warranty gives you specific legal rights, and you may also have other rights which vary from state to state.

---

**TTI Consumer Power Tools, Inc.**

P.O. Box 1427

Anderson, SC 29622 USA

---

# OPERATOR'S MANUAL

## OSCILLATING EDGE BELT/ SPINDLE SANDER

EB44241/EB44242/EB44243/EB4424

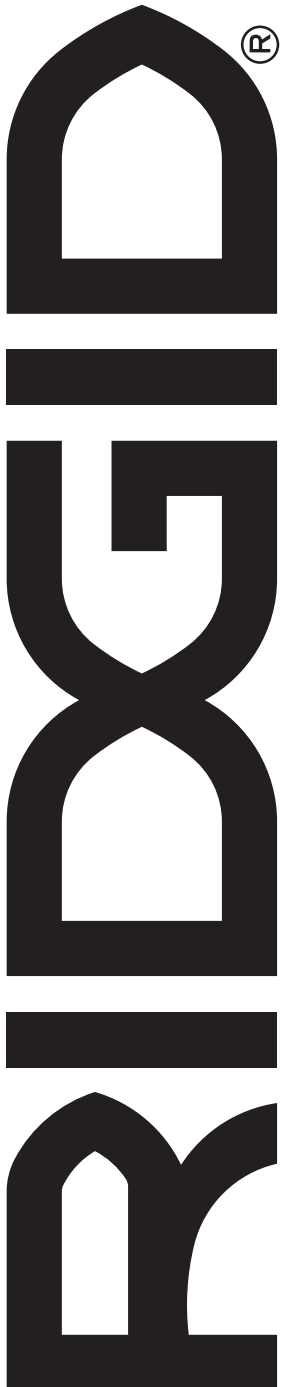

### Customer Service Information:

For parts or service, do not return this product to the store. Contact your nearest RIDGID® authorized service center. Be sure to provide all relevant information when you call or visit. For the location of the authorized service center nearest you, please call 1-866-539-1710 or visit us online at [powertools.ridgid.com](http://powertools.ridgid.com).

MODEL NO.\* \_\_\_\_\_ SERIAL NO. \_\_\_\_\_

*\*Model number on product may have additional letters at the end. These letters designate manufacturing information and should be provided when calling for service.*

---

### Service après-vente :

Pour acheter des pièces ou pour un dépannage, ne pas retourner ce produit au magasin. Contacter le centre de réparations RIDGID® agréé le plus proche. Veiller à fournir toutes les informations pertinentes lors de tout appel téléphonique ou visite. Pour obtenir l'adresse du centre de réparations agréé le plus proche, téléphoner au 1-866-539-1710 ou visiter notre site [powertools.ridgid.com](http://powertools.ridgid.com).

NO. DE MODÈLE\* \_\_\_\_\_ NO. DE SÉRIE \_\_\_\_\_

*\*Le numéro de modèle sur le produit peut contenir des lettres supplémentaires à la fin. Ces lettres désignent les informations du fabricant et doivent être fournies lors d'un appel de demande de service.*

---

### Información sobre servicio al consumidor:

Para piezas de repuesto o servicio, no devuelva este producto a la tienda. Comuníquese con el centro de servicio autorizado de productos RIDGID® de su preferencia. Asegúrese de proporcionar todos los datos pertinentes al llamar o al presentarse personalmente. Para obtener información sobre el centro de servicio autorizado más cercano a usted, le suplicamos llamar al 1-866-539-1710 o visitar nuestro sitio en la red mundial, en la dirección [powertools.ridgid.com](http://powertools.ridgid.com).

NÚM. DE MODELO\* \_\_\_\_\_ NÚM. DE SERIE \_\_\_\_\_

*\*El número de modelo que figura en el producto podría tener letras adicionales al final. Estas designan información de fabricación y deben suministrarse cuando llame para obtener asistencia o servicio.*

### TTI CONSUMER POWER TOOLS, INC.

P.O. Box 1427  
Anderson, SC 29622 USA  
1-866-539-1710 ■ [powertools.ridgid.com](http://powertools.ridgid.com)

*RIDGID is a registered trademark of RIDGID, Inc., used under license.*

983000-482  
11-22-22 (REV:06)