

30-INCH BARREL CHARCOAL GRILL WITH OFFSET SMOKER

PARRILLA DE CARBÓN DE 30 PULGADAS CON AHUMADOR ADJUNTO

GRIL À CHARBON DE 30 POUCES AVEC FUMOIR DÉCALÉ

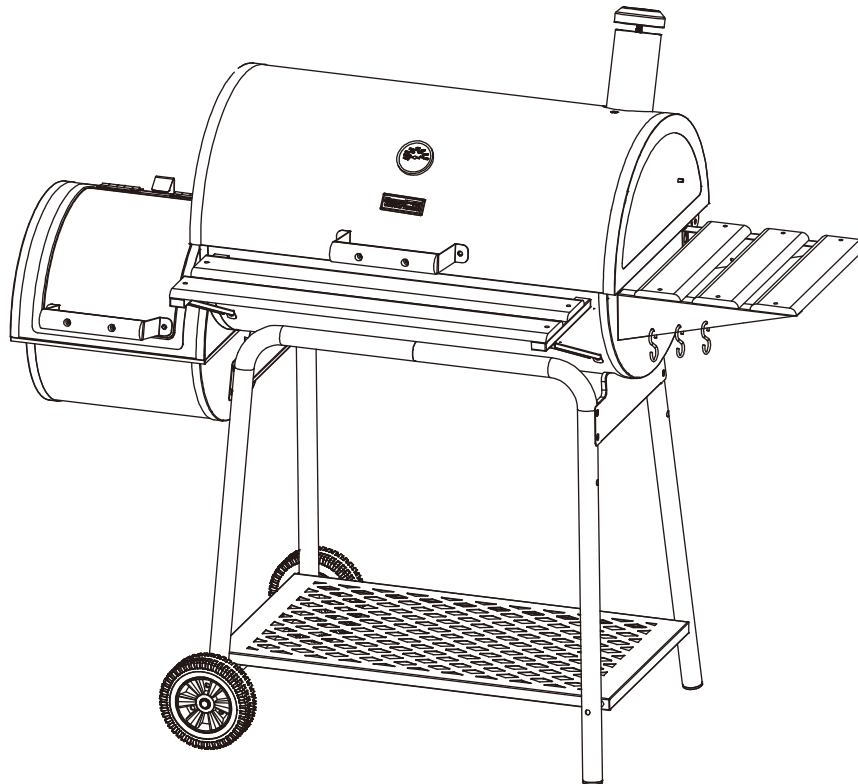

FOR YOUR SAFETY! | ¡PARA SU SEGURIDAD! | POUR VOTRE SÉCURITÉ!

Use outdoors only!
Read the instructions before
assembling and using the appliance.

¡Solo usa al aire libre!
Lea las instrucciones antes
de montar y utilizar el aparato.

Utilisez uniquement à l'extérieur!
Lisez les instructions avant
d'assembler et d'utiliser l'appareil.

CONTACT US FIRST! | ¡PÓNGASE EN CONTACTO CON NOSOTROS PRIMERO! | CONTACTEZ-NOUS D'ABORD!

If you have any questions that are
not addressed, please contact us first.

Si tiene alguna pregunta que no se
aborde en este Manual del Usuario,
póngase en contacto con nosotros primero.

Si vous avez des questions qui ne
sont pas traitées dans ce manuel de
l'utilisateur, contactez-nous d'abord.



Customer Service / Servicio al Cliente / Service de Clientèle



1-800-618-6798











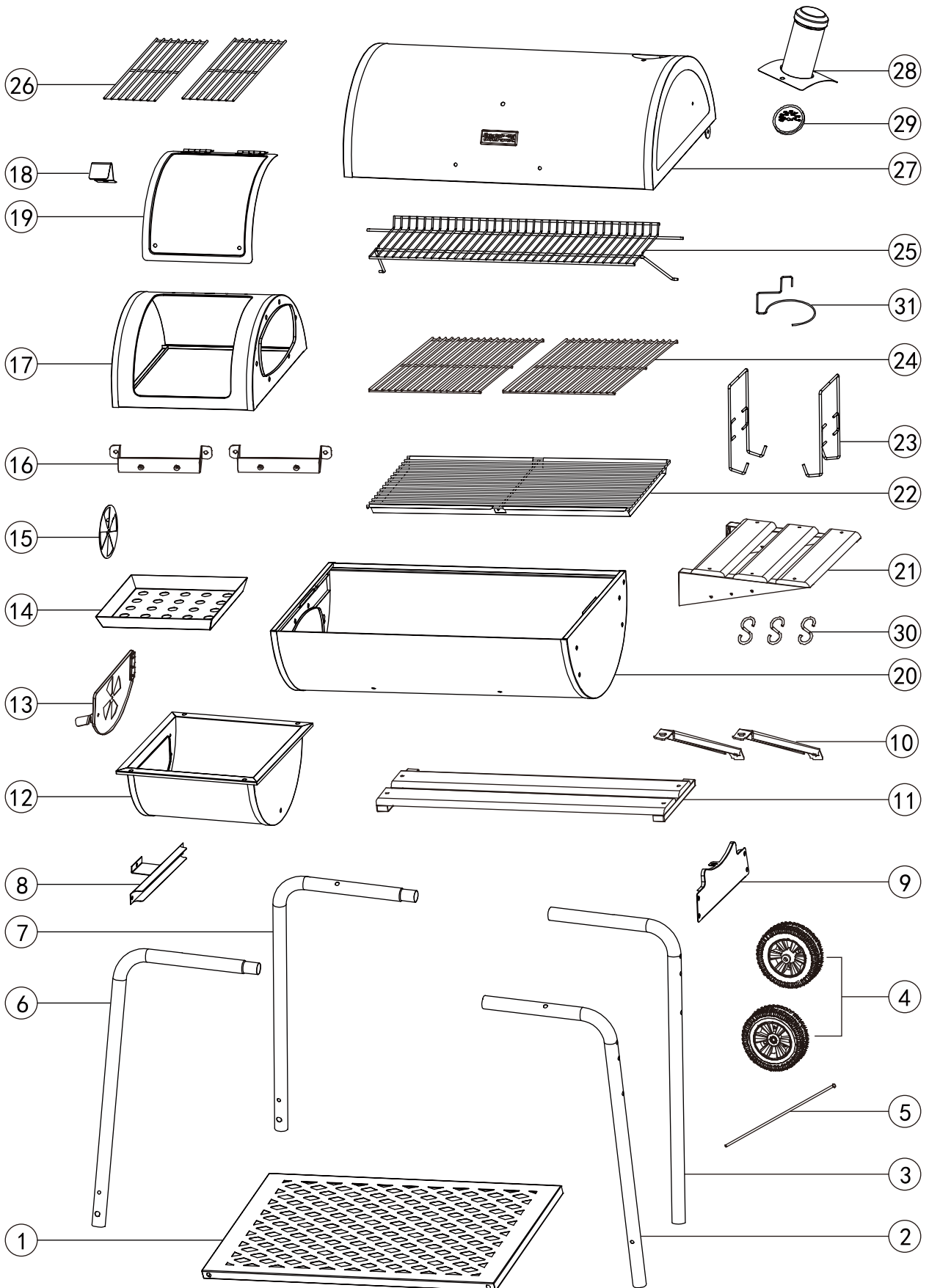





service@royalgourmetusa.com

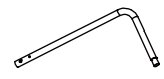
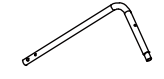
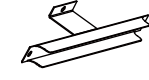



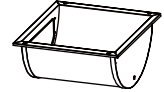

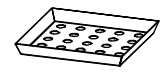

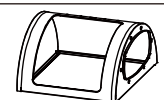





Learn more at / Obtener más información en / Pour en savoir plus:

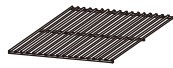













www.royalgourmetcorp.com







No.	#	QYT / CANT. / QTÉ	Description / Descripción / Description	Image / Imagen / Image
1	Z-CC1830056	1	Bottom shelf Estante inferior Étagère inférieure	
2	Z-CC1830S015	1	Right front leg Pata delantera derecha Jambe avant droite	
3	Z-CC1830S014	1	Right back leg Pata trasera derecha Jambe arrière droite	
4	05-SLL-04	2	Wheel Rueda Roue	
5	06-XZL-1-04A-DY	1	Wheel axle Eje de las ruedas Essieu de roue	
6	Z-CC1830S016	1	Left front leg Pata delantera izquierda Jambe avant gauche	
7	Z-CC1830S017	1	Left back leg Pata trasera izquierda Jambe arrière gauche	
8	H-CC1830003	1	Smoker brace Soporte del ahumador Renfort de fumoir	
9	Z-CC1830010	1	Leg brace Placa de sujeción de las patas Renfort de jambe	
10	Z-CC1830031	2	Front table support beam Sujecion del estante frontal Poutre de supports de table avant	
11	08-MZP-08	1	Front table Estante delantero Table avant	
12	H-CC1830012	1	Smoker chamber Compartimento del ahumador Chambre du fumoir	
13	Z-CC1830055	1	Smoker side door Puerta lateral del ahumador Porte de côté du fumoir	
14	Z-CC1830054	1	Smoker charcoal pan Bandeja de carbón del ahumador Bac à charbon du fumoir	
15	TY-YFMP01	1	Damper Amortiguador Amortisseur	
16	08-MZP-03	2	Handle Asa Poignée	
17	H-CC1830S011	1	Smoker chamber top Parte superior del compartimento del ahumador Dessus de la chambre de fumoir	

No.	#	QYT / CANT. / QTÉ	Description / Descripción / Description	Image / Imagen / Image
18	Z-CC1830029	1	Smoker lid connector Tope de la tapa del ahumador Connecteur du couvercle du fumoir	
19	Z-CC1830053	1	Smoker lid Tapa de ahumador Couvercle du fumoir	
20	H-CC1830S013	1	Grill chamber Compartimento de la parrilla Chambre du grill	
21	08-MZP-07	1	Side table Estante lateral Table d'appoint	
22	Z-CC1830008 03-XWJ-C-50- B-PT1	1	Charcoal pan set Conjunto se bandejas de carbón Ensemble de bac à charbon	
23	06-TSL-23-DD1	2	Lifting rack Riel de distintas alturas Grilles de levage	
24	03-XKW-C-09- E-TC3	2	Cooking grate Rejilla para asar Grille de cuisson	
25	03-BWW-C-05-B-DD1 03-WZJ-C-04-A-DD1	1	Warming rack Rejilla para calentar Grille de réchauffement	
26	03-XKW-C-09- G-TC3	2	Smoker cooking grate Rejillas del ahumador Grille de cuisson du fumoir	
27	H-CC1830001	1	Grill chamber lid Tapa del compartimento de la parrilla Couvercle de la chambre du grill	
28	CYC10H CYCG01H	1	Stack Chimenea Cheminée	
29	06-WDJ-1-04	1	Thermometer Termómetro Thermomètre	
30	07-GGL-01-SI	3	Grease cup holder Soporte de la taza de grasa Graisser le porte-gobelet	
31	07-GGL-36	1	Grease cup holder Soporte de la taza de grasa Graisser le porte-gobelet	

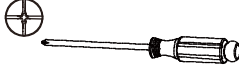
Key / Clave / Réf.	Description / Descripción / Description	QTY / CANT. / QTÉ	Image / Imagen / Image
A	M6x12	36	 
B	M4x8	6	 
C	M6	11	 
D	M6	3	 
E	Split pin Pasador partido Goupille fendue	3	
F	Washer Arandela Rondelle	2	
G	M5x10	4	 
H	M6x45	4	 

TOOLS REQUIRED / HERRAMIENTAS REQUERIDAS / OUTILS REQUIS		
Description / Descripción / Description		Image / Imagen / Image
Phillips screwdriver Destornillador phillips Tournevis phillips	Wrench Llave Clé	 

Before beginning assembly, make sure all parts are present. If any parts are missing or damaged, do not attempt to assemble the products. Contact customer service for replacement parts via telephone or email.

- Tools needed (not included): Phillips screwdriver and wrench
- Approximate assembly time: 40 minutes
- Note: 1. The right and left sides of the grill are designed as if you are facing the front of the grill.
2. Model shown for illustration purpose only, specific please in kind prevail.

Antes de comenzar el montaje, asegúrese de que todas las piezas estén presentes. Si falta alguna pieza o está dañada, no intente ensamblar los productos. Póngase en contacto con el servicio de atención al cliente para obtener piezas de repuesto por teléfono o correo electrónico.

- Herramienta necesaria (no incluido): Destornillador phillips y llave
- Tiempo aproximado de ensamblaje: 40 minutos
- Nota: 1. Los lados derecho e izquierdo de la parrilla están diseñados como si estuvieras frente a la parte delantera de la parrilla.
2. El modelo que se muestra es sólo para fines ilustrativos, prevalecen los específicos en especie.

Avant de commencer l'assemblage, assurez-vous que toutes les pièces sont présentes. Si des pièces sont manquantes ou endommagées, n'essayez pas d'assembler les produits. Contactez le service de clientèle pour les pièces de rechange par téléphone ou par e-mail.

- Outils nécessaires (non inclus): Tournevis phillips et clé
- Temps nécessaire pour l'assemblage: 40 minutes
- Remarque: 1. Les côtés droit et gauche du gril sont conçus comme si vous faisiez face à l'avant du gril.
2. Le modèle est présenté à des fins d'illustration uniquement, spécifiques en nature prévalent.

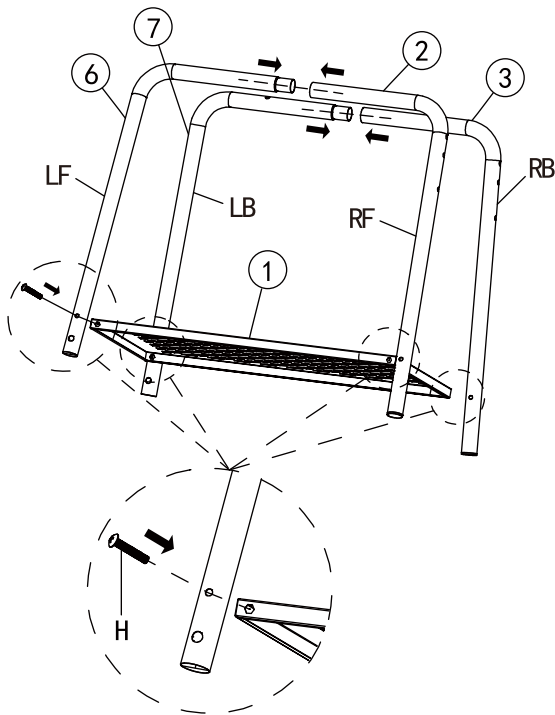

1 H  ×4



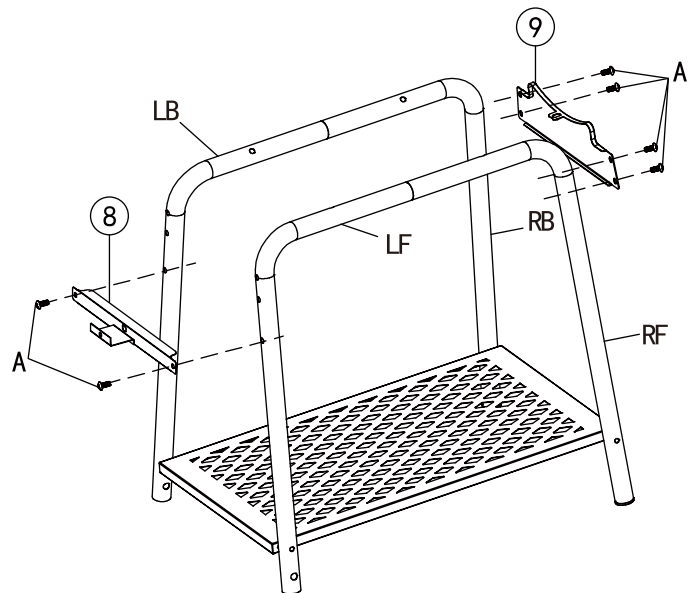

2 A  ×6

- Do not secure the bolts until step 4.
- No apretar las tornillos hasta el paso 4.
- Ne pas fixer les boulons avant l'étape 4.

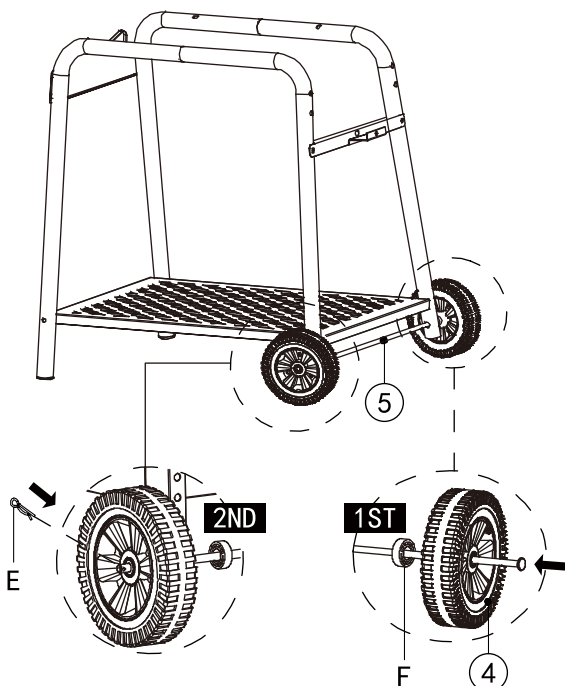

3 E  ×1
F  ×2



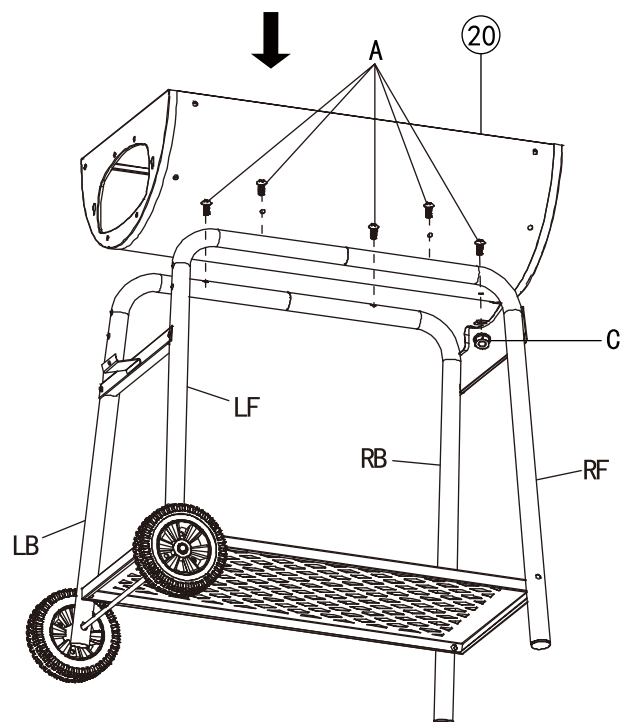

4 A  ×5
C  ×1



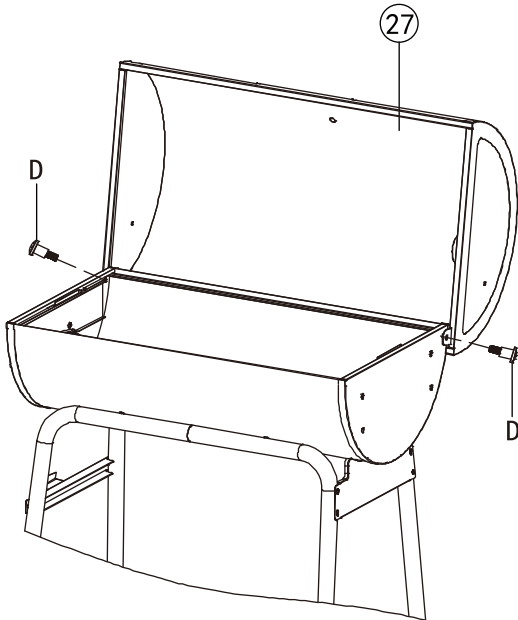

5	D		x2

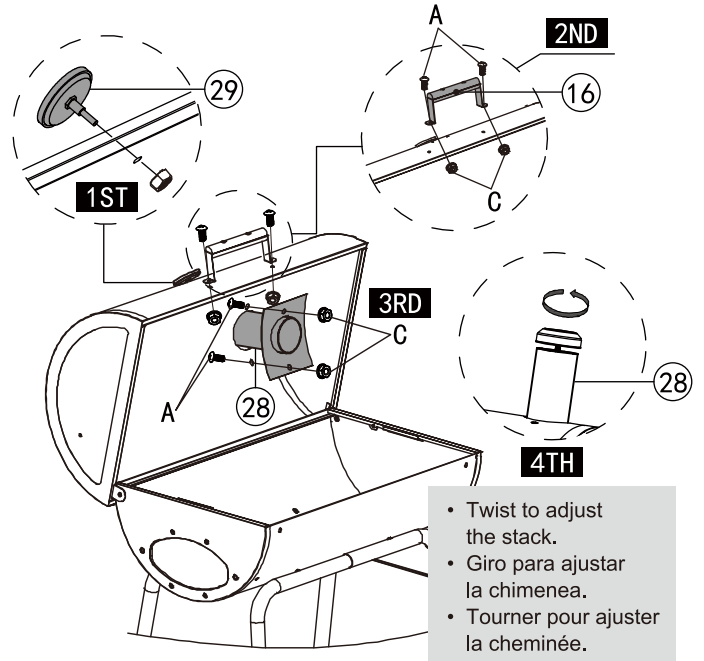

6	A		x4
	C		x4



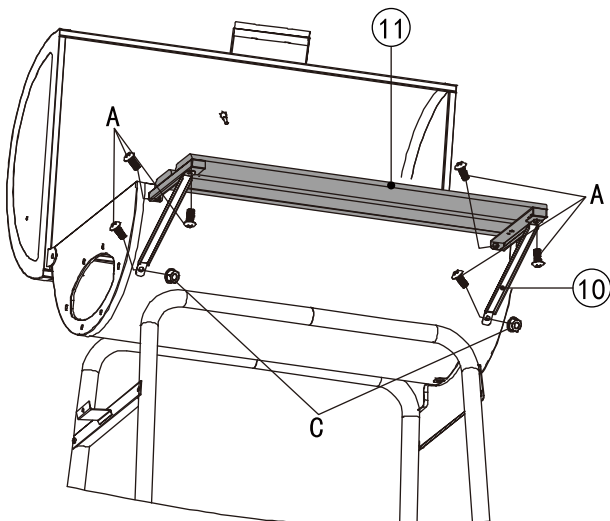

7	A		x6
	C		x2

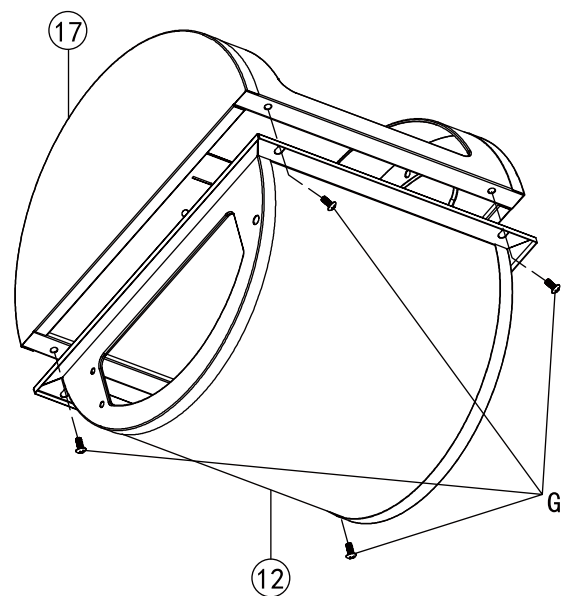

8	G		x4





9	A		×1
	C		×1

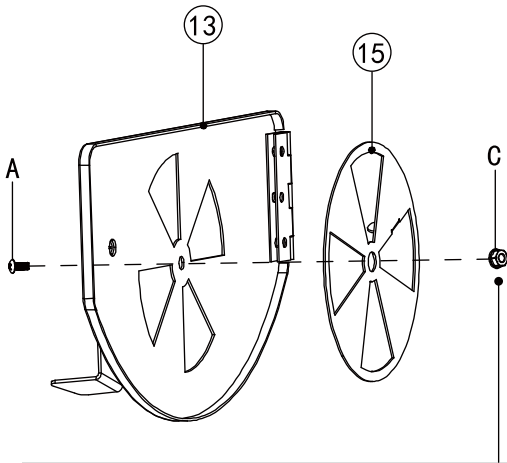

- Note direction.
- Dirección de la nota.
- Direction de la note.



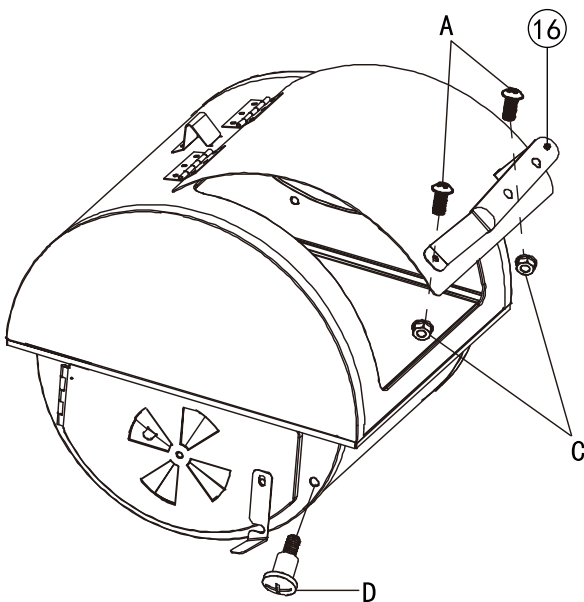

- Tighten just enough to allow the damper to revolve freely.
- Ajuste lo suficiente como para permitir que los reguladores giren libremente.
- Serrez juste assez pour permettre les amortisseurs de tourner librement.

11	D		×1
	A		×2
	C		×2

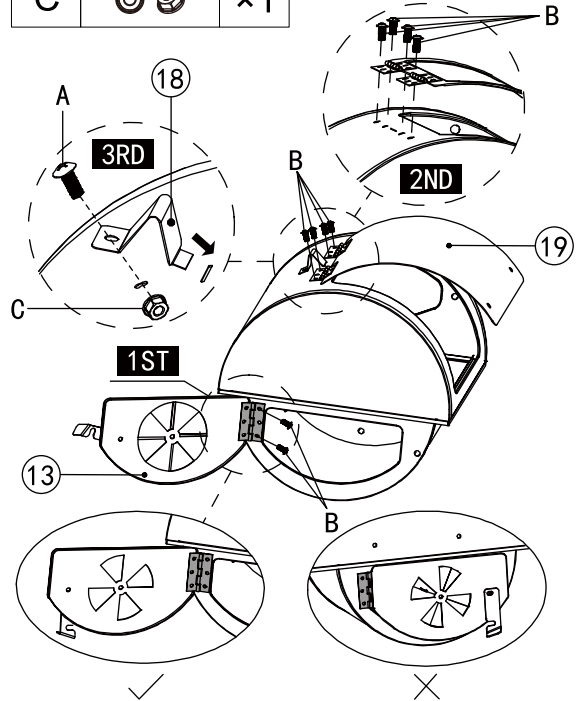

10	A		×1
	B		×6
	C		×1



12	A		×7
-----------	---	--	----

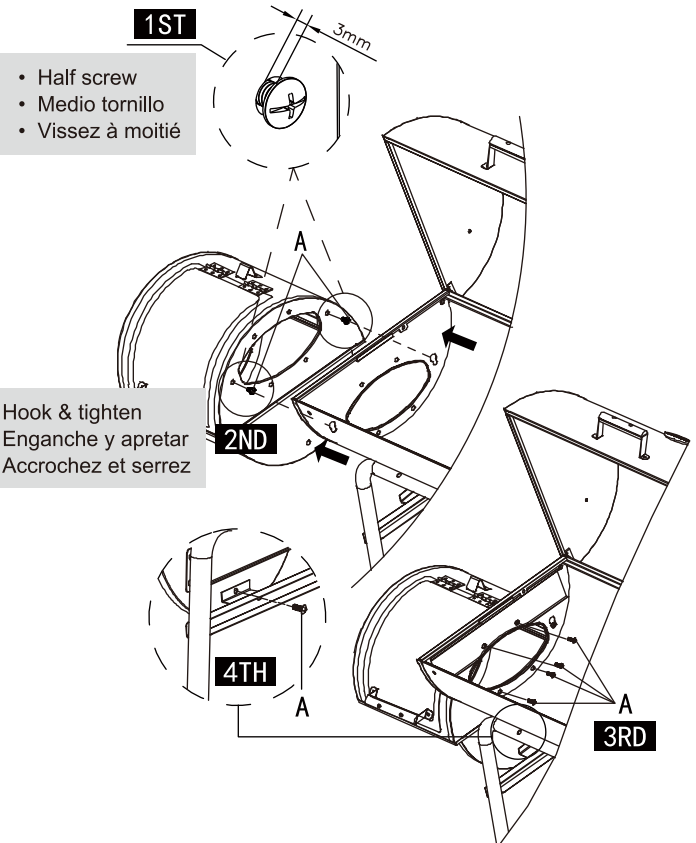

13

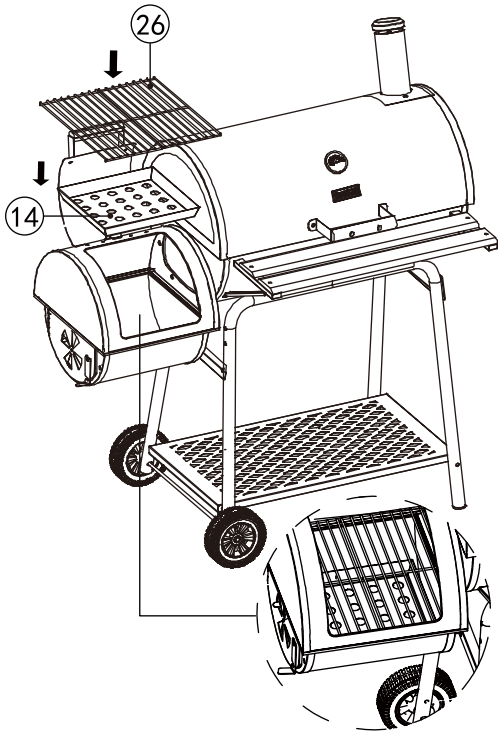

14

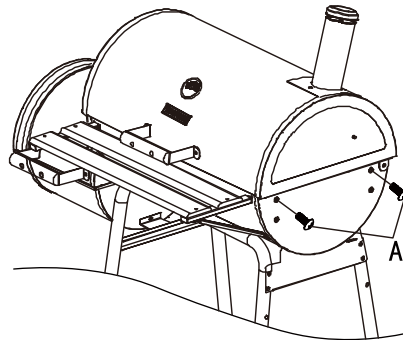
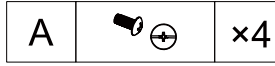

1ST

- Half screw
- Medio tornillo
- Vissez à moitié

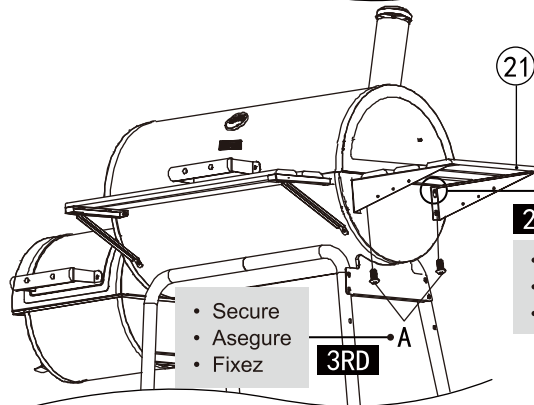

2ND

- Tighten
- Apretar
- Serrez

3RD

- Secure
- Asegure
- Fixez

15

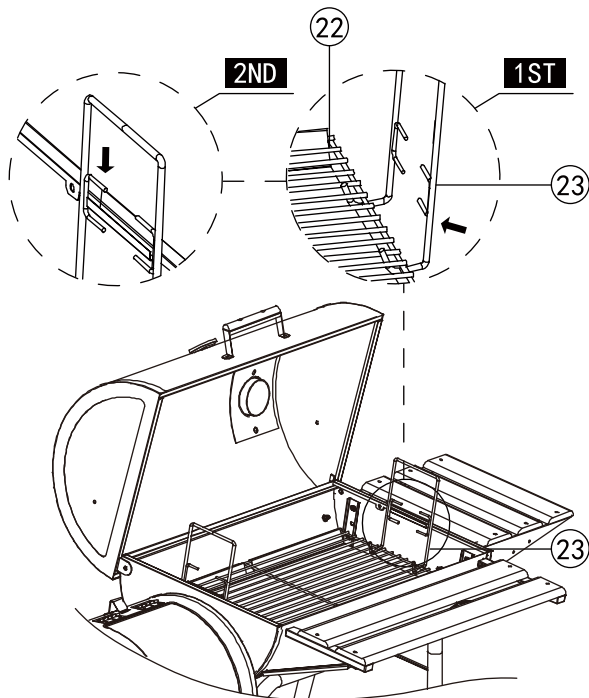

16

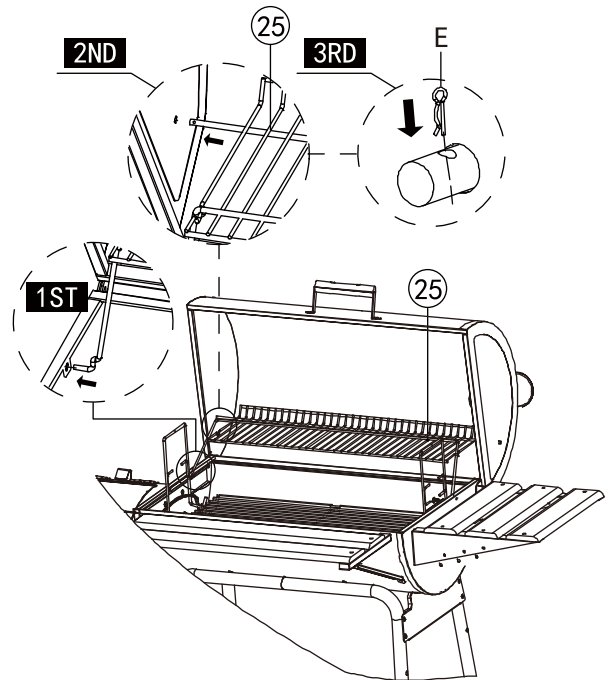

17

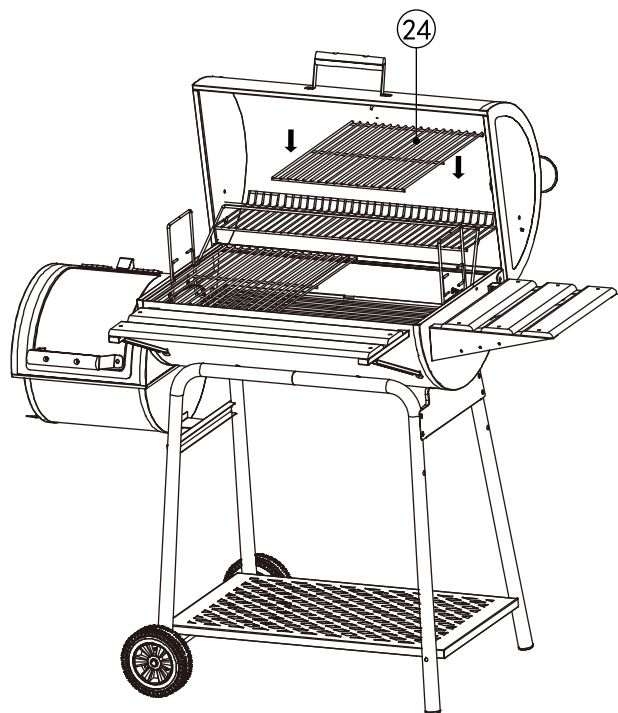

18

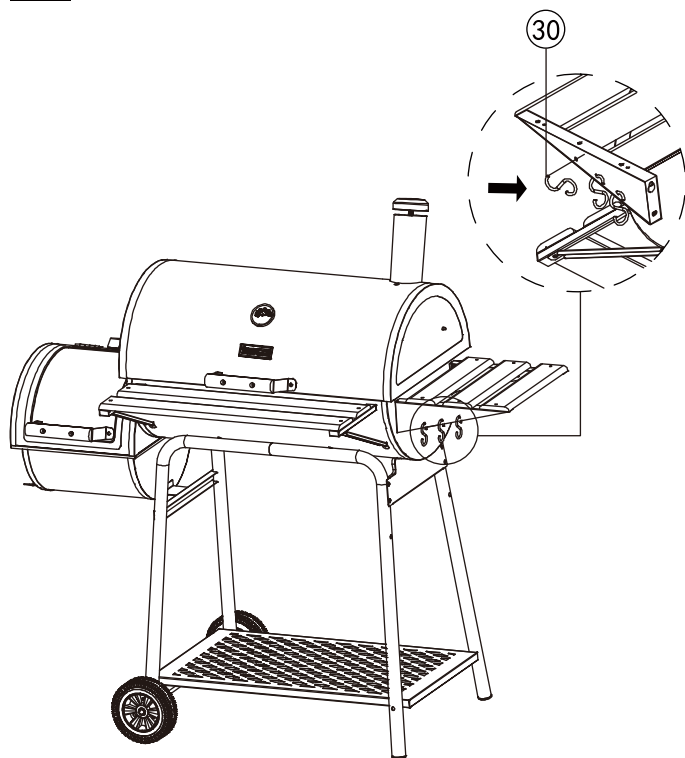

19

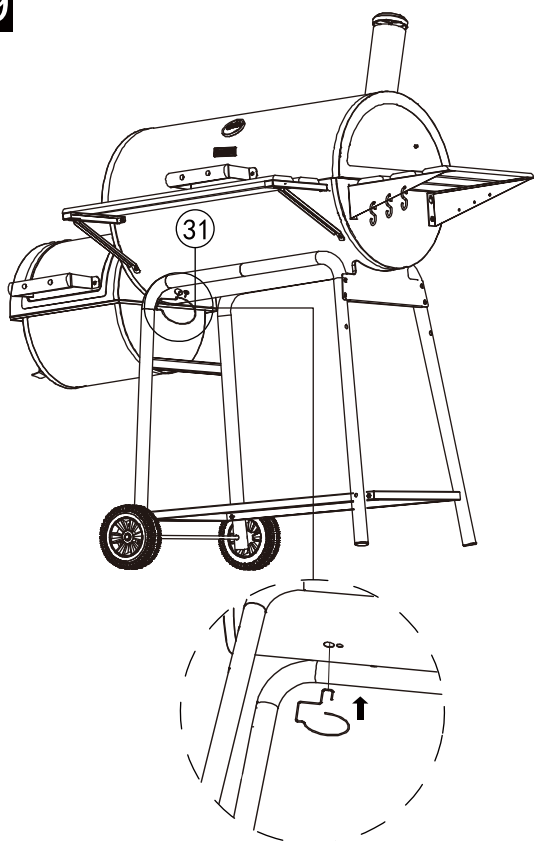

**Thank You
For Choosing Us.**

**Any Problem!
We Can Help!**

**Customer
Service**

1-800-618-6798

Monday to Friday (8:30 am - 5:00 pm EST)

service@royalgourmetusa.com