



Operating Instructions and Parts Manual Toe Jack

Models JTJ-2ST, JTJ-5ST and JTJ-10ST



(5-Ton model shown)

JET
427 New Sanford Road
LaVergne, Tennessee 37086
Ph.: 800-274-6848
www.jettools.com

Part No. M-454502
Revision B 03/2016
Copyright © 2014 JET

Warranty and Service

JET warrants every product it sells against manufacturers' defects. If one of our tools needs service or repair, please contact Technical Service by calling 1-800-274-6846, 8AM to 5PM CST, Monday through Friday.

Warranty Period

The general warranty lasts for the time period specified in the literature included with your product or on the official JET branded website.

- JET products carry a limited warranty which varies in duration based upon the product. (See chart below)
- Accessories carry a limited warranty of one year from the date of receipt.
- Consumable items are defined as expendable parts or accessories expected to become inoperable within a reasonable amount of use and are covered by a 90 day limited warranty against manufacturer's defects.

Who is Covered

This warranty covers only the initial purchaser of the product from the date of delivery.

What is Covered

This warranty covers any defects in workmanship or materials subject to the limitations stated below. This warranty does not cover failures due directly or indirectly to misuse, abuse, negligence or accidents, normal wear-and-tear, improper repair, alterations or lack of maintenance. JET woodworking machinery is designed to be used with Wood. Use of these machines in the processing of metal, plastics, or other materials outside recommended guidelines may void the warranty. The exceptions are acrylics and other natural items that are made specifically for wood turning.

Warranty Limitations

Woodworking products with a Five Year Warranty that are used for commercial or industrial purposes default to a Two Year Warranty. Please contact Technical Service at 1-800-274-6846 for further clarification.

How to Get Technical Support

Please contact Technical Service by calling 1-800-274-6846. **Please note that you will be asked to provide proof of initial purchase when calling.** If a product requires further inspection, the Technical Service representative will explain and assist with any additional action needed. JET has Authorized Service Centers located throughout the United States. For the name of an Authorized Service Center in your area call 1-800-274-6846 or use the Service Center Locator on the JET website.

More Information

JET is constantly adding new products. For complete, up-to-date product information, check with your local distributor or visit the JET website.

How State Law Applies

This warranty gives you specific legal rights, subject to applicable state law.

Limitations on This Warranty

JET LIMITS ALL IMPLIED WARRANTIES TO THE PERIOD OF THE LIMITED WARRANTY FOR EACH PRODUCT. EXCEPT AS STATED HEREIN, ANY IMPLIED WARRANTIES OF MERCHANTABILITY AND FITNESS FOR A PARTICULAR PURPOSE ARE EXCLUDED. SOME STATES DO NOT ALLOW LIMITATIONS ON HOW LONG AN IMPLIED WARRANTY LASTS, SO THE ABOVE LIMITATION MAY NOT APPLY TO YOU.

JET SHALL IN NO EVENT BE LIABLE FOR DEATH, INJURIES TO PERSONS OR PROPERTY, OR FOR INCIDENTAL, CONTINGENT, SPECIAL, OR CONSEQUENTIAL DAMAGES ARISING FROM THE USE OF OUR PRODUCTS. SOME STATES DO NOT ALLOW THE EXCLUSION OR LIMITATION OF INCIDENTAL OR CONSEQUENTIAL DAMAGES, SO THE ABOVE LIMITATION OR EXCLUSION MAY NOT APPLY TO YOU.

JET sells through distributors only. The specifications listed in JET printed materials and on official JET website are given as general information and are not binding. JET reserves the right to effect at any time, without prior notice, those alterations to parts, fittings, and accessory equipment which they may deem necessary for any reason whatsoever. JET® branded products are not sold in Canada by JPW Industries, Inc.

Product Listing with Warranty Period

90 Days – Parts; Consumable items
1 Year – Motors; Machine Accessories
2 Year – Metalworking Machinery; Electric Hoists, Electric Hoist Accessories; Woodworking Machinery used for industrial or commercial purposes
5 Year – Woodworking Machinery
Limited Lifetime – JET Parallel clamps; VOLT Series Electric Hoists; Manual Hoists; Manual Hoist Accessories; Shop Tools; Warehouse & Dock products; Hand Tools; Air Tools

NOTE: JET is a division of JPW Industries, Inc. References in this document to JET also apply to JPW Industries, Inc., or any of its successors in interest to the JET brand.



Warnings

1. Read and understand the entire owner's manual before attempting to operate the toe jack.
2. This toe jack was designed and intended for use by properly trained personnel only. If you are not familiar with the proper and safe use of a toe jack, do not use this jack until proper training and knowledge have been obtained.
3. Use the jack on hard, level surfaces only. Never use the jack on a slope or soft surfaces.
4. Never load the toe jack beyond its rated capacity.
5. Support raised loads with appropriate supports. Never use the toe jack as a sole means of support.
6. Keep arms, legs, fingers and toes clear of a lifted load at all times.
7. Do not add weight to a supported load.
8. Keep lifted loads as low as possible.
9. Remove the handle from the toe jack body when not in use. Never use any handle other than the one designed for the toe jack.
10. Retract the ram completely when you are finished using the jack. An extended ram might get damaged.
11. Do not lower a load suddenly and stop in the middle of a lift. Damage to the jack may occur.
12. Replace the warning label on the jack if it is damaged or unreadable.
13. Failure to comply with all these warnings may cause serious injury and/or damage to property.

Specifications

Model	Stock No.	Toe Capcty (tons)	Head Capcty (tons)	Toe Height min. (in.)	Toe Height max. (in.)	Toe Lift (in.)	Head Height min. (in.)	Head Height max. (in.)	Toe Size (L x W) (in.)	Base Size (L x W) (in.)	Net Weight (lbs.)
JTJ-2ST	454502	2	3	5/8	5-1/16	4-7/16	9-1/4	13-3/4	2 x 2	4-15/16 x 7	20
JTJ-5ST	454505	5	6	1-1/16	5-3/4	4-11/16	11-1/2	16-1/4	2.5 x 3	10-5/8 x 7-3/16	48
JTJ-10ST	454510	10	14	1-7/32	6-15/16	5-23/32	12-7/8	18-9/16	2.72 x 3.3	11-9/32 x 9-7/16	81

The above specifications were current at the time this manual was published, but because of our policy of continuous improvement, JET reserves the right to change specifications at any time and without prior notice, without incurring obligations.

Unpacking

Open shipping carton, which should contain one toe jack and one 2-piece handle. Check for shipping damage. Report any damage immediately to your distributor and shipping agent. Do not discard any shipping material until the toe jack is set up and operating properly.

Operation

NOTE: Repeated operation near or at the rated capacity may cause undue wear and shorten jack life.

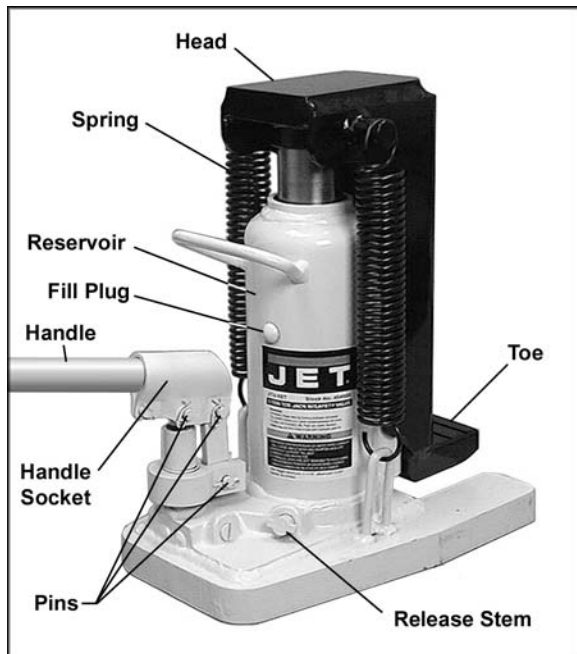

Figure 1 (5-ton model shown)

To raise the jack (see Figure 1):

1. Assemble the handle and place the end of the handle over the release stem.
2. Turn the release stem clockwise completely to close the valve. Do not over tighten.
3. Insert the handle into the handle socket.
4. Pump the handle to raise the load.

To lower the jack:

1. Place the end of the handle onto the release stem and turn **slowly** counterclockwise to open the valve.
2. Do not turn the release valve around more than two complete revolutions.

WARNING Turning the release valve too quickly will make the load fall rapidly, and may lead to loss of load or damage to the jack. Failure to comply may cause serious injury and/or property damage.

When storing the jack, lower the ram completely and wipe off any dirt, oil, or other contaminants.

Lubrication

1. Lubricate the pins (Figure 1) with a few drops of machine tool oil monthly.
2. Lubricate the slide (Figure 2) with #2 lithium base grease monthly.

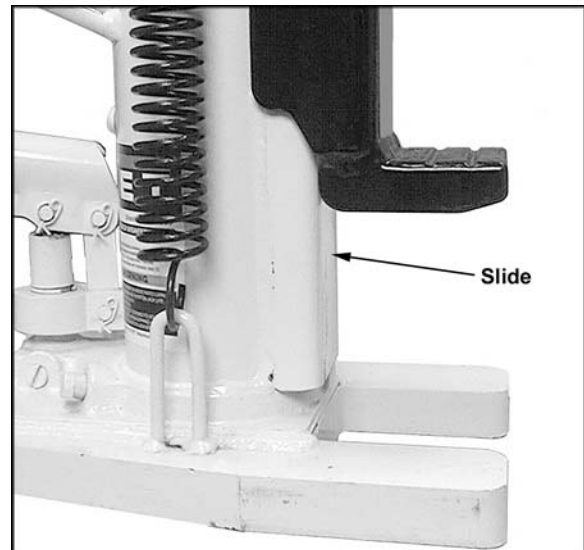

Figure 2

To fill the reservoir with oil:

1. Completely lower the ram.
2. Remove the fill plug (Figure 1).
3. Fill the reservoir with hydraulic jack oil to the bottom edge of the fill hole with the jack in the upright position.

WARNING Make sure no contaminants enter the cylinder when filling with oil. Never use any oil other than hydraulic jack oil to fill the cylinder.

4. Replace the fill plug.
5. Raise the ram to its full height and pump five or six times after the ram has reached its full height.
6. Push the ram down completely.
7. Push the fill plug sideways to let the trapped air bleed out.

Troubleshooting

Trouble	Probable Cause	Remedy
Toe will not extend.	Release stem is open.	Close release stem completely.
	Dirt or crack in valve sealing section.	Clean and repair or replace.
Jack will not lift to full height.	Not enough or too much hydraulic jack oil in reservoir.	Fill reservoir with correct amount of hydraulic jack oil.
Toe extends, but falls immediately.	Air in the system.	Press ram down to the lowest position and let air out by pushing fill plug sideways.
External oil leak.	Damage to top or bottom of reservoir, release stem, or pump.	Repair or replace.

Replacement Parts

Replacement parts are listed on the following pages. To order parts or reach our service department, call 1-800-274-6848 between 8:00 a.m. and 5:00 p.m. (CST), Monday through Friday. Having the Model Number and Serial Number of your machine available when you call will allow us to serve you quickly and accurately.

JTJ-2ST

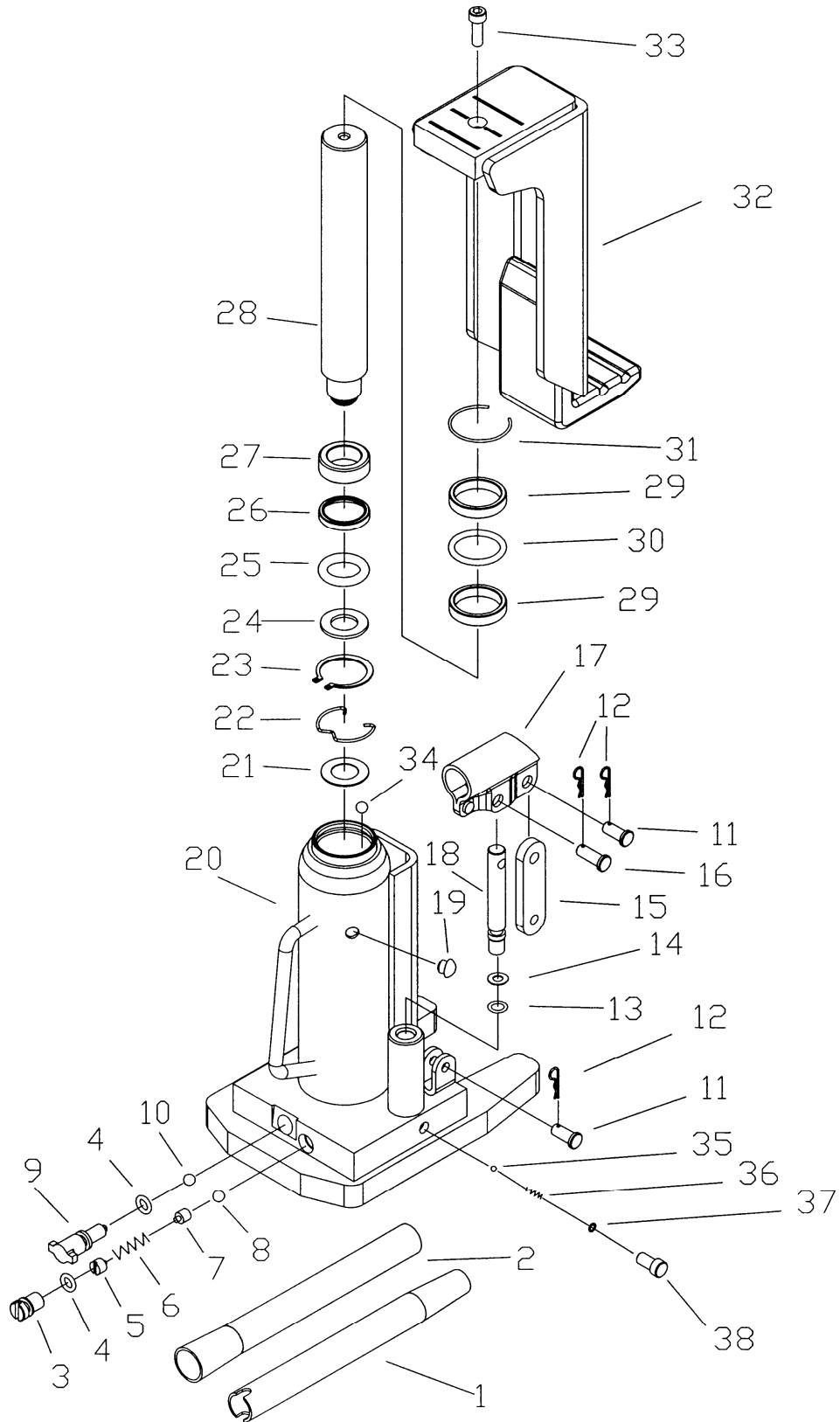

Parts List for JTJ-2ST 2-Ton Toe Jack

Index No.	Part No.	Description	Size	Qty
1	JTJ2ST-01	Rear Handle		1
2	JTJ2ST-02	Front Handle		1
3	JTJ2ST-03	Sealing Bolt		1
4	JTJ10ST-03	O-Ring	7.1x2.65mm	2
5	JTJ2ST-05	Adjusting Screw		1
6	JTJ2ST-06	Safety Valve Spring		1
7	JTJ2ST-07	Ball Seat		1
8	SB-4MM	Steel Ball	4mm	1
9	JTJ2ST-09	Release Stem		1
10	SB-6MM	Steel Ball	6mm	1
11	JTJ2ST-11	Pin		2
12	JTJ2ST-12	Pin		3
13	JTJ2ST-13	O-Ring	6.7x1.8mm	1
14	JTJ2ST-14	Nylon Gasket		1
15	JTJ2ST-15G	Rod Joint		1
16	JTJ2ST-16	Pin		1
17	JTJ2ST-17G	Handle Socket		1
18	JTJ2ST-18	Pump Plunger		1
19	JTJ2ST-19	Oil Fill Plug		1
20	JTJ2ST-20G	Body		1
21	JTJ2ST-21	Washer		1
22	JTJ2ST-22	Snap Ring		1
23	JTJ2ST-23	Snap Ring	16mm	1
24	JTJ2ST-24	Washer		1
25	JTJ2ST-25	O-Ring	19.5x5.3mm	1
26	JTJ2ST-26	Sealing Washer		1
27	JTJ2ST-27	Piston Ring		1
28	JTJ2ST-28	Ram		1
29	JTJ2ST-29	Bushing		2
30	JTJ2ST-30	O-Ring	26.4x3.6mm	1
31	JTJ2ST-31	Snap Ring		1
32	JTJ2ST-32G	Toe		1
33	TS-1503041	Socket Head Cap Screw	M6x16	1
34	SB-5MM	Steel Ball	5mm	1
35	SB-5MM	Steel Ball	5mm	1
36	JTJ2ST-36	Spring		1
37	JTJ2ST-37	Washer		1
38	JTJ2ST-38	Screw		1
	JTJ2ST-ID	ID Label (not shown)		1

JTJ-5ST and JTJ-10ST

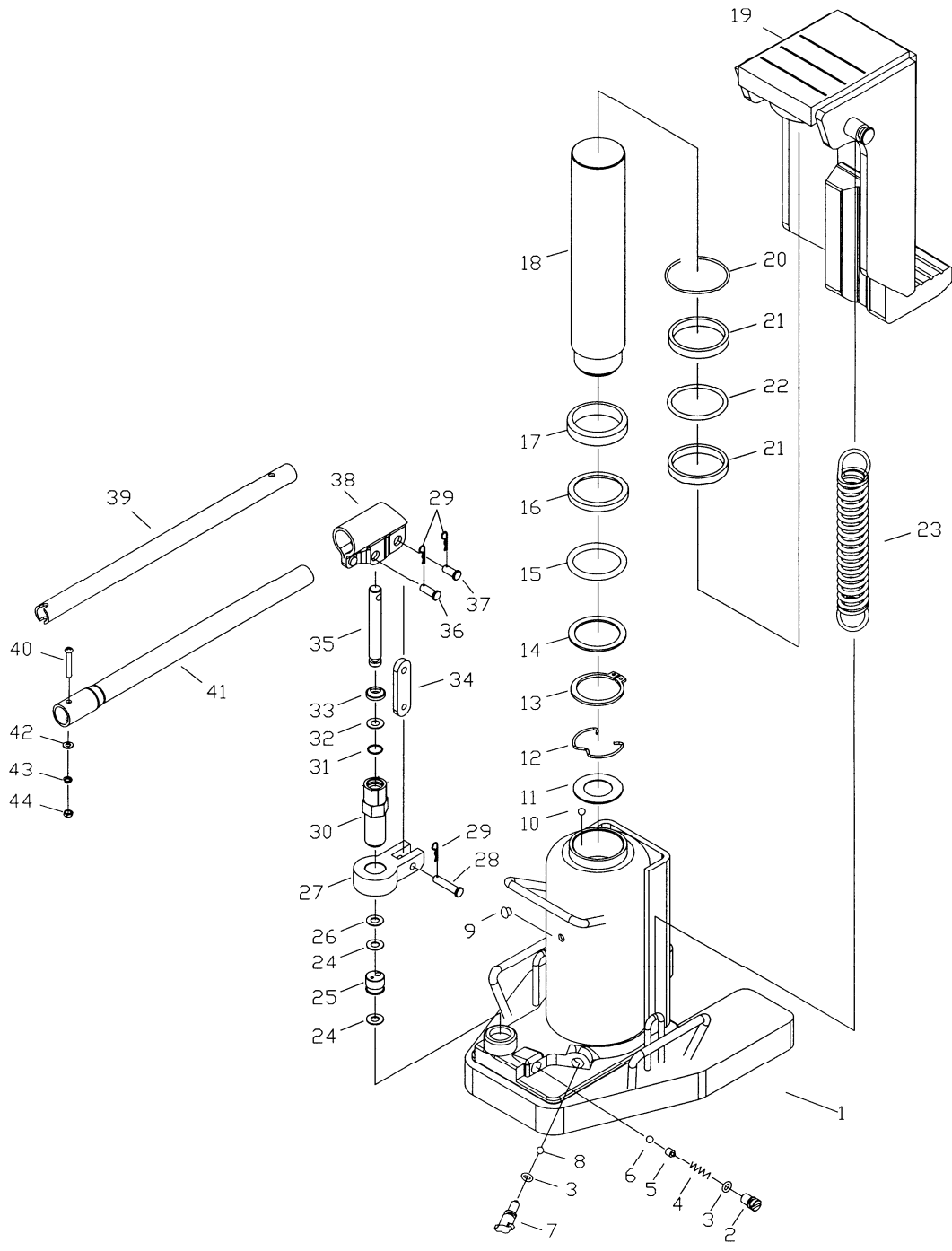

Parts List for JTJ-5ST 5-Ton Toe Jack

Index No.	Part No.	Description	Size	Qty
1	JTJ5ST-01G	Body		1
2	JTJ5ST-02	Safety Valve Screw		1
3	JTJ10ST-03	O-Ring	7.1x2.65mm	2
4	JTJ5ST-04	Safety Valve Spring		1
5	JTJ5ST-05	Ball Seat		1
6	SB-4MM	Steel Ball	4mm	1
7	JTJ5ST-07	Release Stem		1
8	SB-6MM	Steel Ball	6mm	1
9	JTJ5ST-09	Oil Fill Plug		1
10	SB-5MM	Steel Ball	5mm	2
11	JTJ5ST-11	Washer		1
12	JTJ5ST-12	Snap Ring		1
13	JTJ5ST-13	Snap Ring	34mm	1
14	JTJ5ST-14	Washer		1
15	JTJ5ST-15	O-Ring	35.5x4.6mm	1
16	JTJ5ST-16	Sealing Washer		1
17	JTJ5ST-17	Piston Ring		1
18	JTJ5ST-18	Ram		1
19	JTJ5ST-19G	Toe		1
20	JTJ5ST-20	Snap Ring		1
21	JTJ5ST-21	Bushing		2
22	JTJ5ST-22	O-Ring	42.5x3.55mm	1
23	JTJ5ST-23	Return Spring		2
24	JTJ5ST-24	Copper Washer		2
25	JTJ5ST-25	Oil Valve Assembly		1
26	JTJ5ST-26	Nylon Gasket		1
27	JTJ5ST-27G	Link Base		1
28	JTJ5ST-28	Pin		1
29	JTJ5ST-29	Pin		3
30	JTJ5ST-30	Pump Cylinder		1
31	JTJ10ST-31	O-Ring	6.6x3mm	1
32	JTJ5ST-32	Nylon Gasket		1
33	JTJ5ST-33	Dustproof Ring		1
34	JTJ5ST-34G	Rod Joint		1
35	JTJ5ST-35	Pump Plunger		1
36	JTJ5ST-36	Pin		1
37	JTJ5ST-37	Pin		1
38	JTJ5ST-38G	Handle Socket		1
39	JTJ5ST-39	Rear Handle		1
40	TS-2285302	Pan Head Screw	M5x30	1
41	JTJ10ST-41	Front Handle		1
42	TS-1550031	Flat Washer	M5	1
43	TS-2361051	Lock Washer	M5	1
44	TS-1540031	Hex Nut	M5	1
	JTJ5ST-ID	ID Label (not shown)		1

Parts List for JTJ-10ST 10-Ton Toe Jack

Index No.	Part No.	Description	Size	Qty
1	JTJ10ST-01G	Body		1
2	JTJ10ST-02	Safety Valve Screw		1
3	JTJ10ST-03	O-Ring	7.1x2.65mm	2
4	JTJ10ST-04	Safety Valve Spring		1
5	JTJ10ST-05	Ball Seat		1
6	SB-4MM	Steel Ball	4mm	1
7	JTJ10ST-07	Release Stem		1
8	SB-6MM	Steel Ball	6mm	1
9	JTJ10ST-09	Oil Fill Plug		1
10	SB-5MM	Steel Ball	5mm	2
11	JTJ10ST-11	Washer		1
12	JTJ10ST-12	Snap Ring		1
13	JTJ10ST-13	Snap Ring	40mm	1
14	JTJ10ST-14	Washer		1
15	JTJ10ST-15	O-Ring	46.2x5.7mm	1
16	JTJ10ST-16	Sealing Washer		1
17	JTJ10ST-17	Piston Ring		1
18	JTJ10ST-18	Ram		1
19	JTJ10ST-19G	Toe		1
20	JTJ10ST-20	Snap Ring		1
21	JTJ10ST-21	Bushing		2
22	JTJ10ST-22	O-Ring	51.5x4.6mm	1
23	JTJ10ST-23	Return Spring		2
24	JTJ10ST-24	Copper Washer		2
25	JTJ10ST-25	Oil Valve Assembly		1
26	JTJ10ST-26	Nylon Gasket		1
27	JTJ10ST-27G	Link Base		1
28	JTJ10ST-28	Pin		1
29	JTJ10ST-29	Pin		3
30	JTJ10ST-30	Pump Cylinder		1
31	JTJ10ST-31	O-Ring	6.6x3mm	1
32	JTJ10ST-32	Nylon Gasket		1
33	JTJ10ST-33	Dustproof Ring		1
34	JTJ10ST-34G	Rod Joint		1
35	JTJ10ST-35	Pump Plunger		1
36	JTJ10ST-36	Pin		1
37	JTJ10ST-37	Pin		1
38	JTJ10ST-38G	Handle Socket		1
39	JTJ10ST-39	Rear Handle		1
40	TS-2285302	Pan Head Screw	M5x30	1
41	JTJ10ST-41	Front Handle		1
42	TS-1550031	Flat Washer	M5	1
43	TS-2361051	Lock Washer	M5	1
44	TS-1540031	Hex Nut	M5	1
	JTJ10ST-ID	ID Label (not shown)		1



427 New Sanford Road
LaVergne, Tennessee 37086
Phone: 800-274-6848
www.jettools.com