

CAUTION: ASBESTOS IN EXISTING FLOOR: This product does not contain asbestos. Existing installed resilient flooring and asphaltic adhesive may contain asbestos fillers or crystalline silica. Do not sand, dry sweep, dry scrape, drill, saw, bead-blast, or mechanically chip or pulverize existing resilient flooring, backing, lining felt, asphaltic "cutback" adhesive or other adhesive. See "Recommended Work Practices for Removal of Resilient Floor Coverings" (rfci.com) for detailed information and instructions on removing all resilient covering structures.

CAUTION: DO NOT INSTALL IN all exterior installations, seasonal porches, boats, campers, RV's, sunrooms, solariums, non-temperature controlled rooms or homes.

Safety and Health Precautions

Power tools can be dangerous. Operate in strict accordance to manufacturer's operating instructions and safety precautions. Unsafe and improper use can cause serious injuries. Avoid inhalation and exposures to airborne particles by mechanical means and by wearing personal protective equipment. Wear appropriate personal protective equipment (PPE) which includes NIOSH or OSHA approved dust masks, safety goggles and work gloves.

Warranty

This flooring product comes with a manufacturer Limited Wear Warranty. The warranty applies to the original purchaser of the flooring. It warrants the original purchaser that the finish surface will not wear through for the duration of the stated warranty from the date of purchase. Contact our Customer Service Team at 1-714-685-7568 to request a written copy which provides detailed terms of coverage and limitations.

Pre-Installation

OWNER/INSTALLER RESPONSIBILITY

The owner is advised to be at home during the installation for consultation/direction. The owner and installer should discuss installation and layout to maximize satisfaction. If this is not possible, consultation should be done prior to installation. The owner/installer assumes all responsibility for product quality of completed installation.

PERFORM PRE-INSTALL INSPECTION. FOR CLAIMS PURPOSES, YOU ARE ALLOWED TO OPEN UP TO 4 BOXES FOR PRODUCT INSPECTION. DO NOT OPEN ALL THE BOXES. OPENING ALL THE BOXES CONSTITUTES YOUR ACCEPTANCE OF THE PRODUCT. INSPECT ALL THE TILES IN THESE 4 BOXES CAREFULLY. EXAMINE FLOORING FOR COLOR, FINISH AND QUALITY. IF YOU DISCOVER THAT PRODUCTS ARE DEFECTIVE, OR IF MATERIAL IS QUESTIONABLE, YOU SHOULD CONTACT THE RETAILER. IF YOU ARE SATISFIED, PROCEED WITH INSTALLATION.

Prior to installation, rack up planks/tiles from several boxes to ensure uniform distribution of colors, shades and characters in the installed flooring. Planks/tiles having similar widths should be placed together in the same row to minimize gaps between boards.

Purchase flooring to be installed in one large area at the same time. Product purchased at a later time than the first purchase may vary beyond your expectations.

Accessories, trims and moldings are manufactured to coordinate with the varied appearances of the floor planks/tiles. Any exact matches are coincidental. Non-matching accessories are not defective products.

This product is manufactured according to strict quality standards. In the event that defects are discovered in the field, the industry standards permit a defect tolerance not to exceed 5%. Order an additional 10% extra for cutting wastage and grading allowances (more for diagonal installations).

During installation, inspect the planks/tiles continuously. Defects that can be seen from a standing position should be cut off or held out. Installing defective planks/tiles implies acceptance.

Clicking noises are the result of interactions among flooring, joists and subfloors when they move. Sometimes, it is impossible to eliminate them completely and minor clicking noises are to be accepted as normal flooring phenomenon.

IMPORTANT: With square edge products, some ledging can be visible up to a .15 mm variance.

To assure the warranty is not inadvertently voided, before proceeding with any activity that is not covered in this manual, please contact our Customer Support Team at 1-714-685-7568.

CONCRETE SUBFLOOR REQUIREMENTS

Concrete subfloors must:

- Have minimum rated strength of 3000 psi.
- Be level to within 3/16 in. in a 10 ft. span; no bumps or low spots. High spots can be removed by grinding; depressions can be filled with patching compound formulated for use in floor installation. Subfloors should not slope more than 1 in. per 6 ft.
- Be clean; no construction debris, soil, mud and any other objects on or adhering to the floor; if necessary, scrape and sweep away before the installation; no protrusions of nails, debris, metals should remain.
- New concrete slab must cure for at least 90 days. It must have a minimum 10 mil polyethylene sheet between the ground and the concrete.
- Be free from moisture related conditions which can damage the installed flooring.

CONCRETE MOISTURE

Test all concrete subfloors for moisture content and document the results with a photo. For full warranty coverage, we recommend documenting your test results with a photo. Visual checks are not reliable.

Perform tests at locations around exterior doorways, near walls containing plumbing, near foundation walls and in the center of the room. Minimum sample size is 3 samples per 1000 sq. ft. of area and one test for every additional 1000 sq. ft. thereafter.

Moisture content should meet one of the following criteria:

- 4% max. when tested using Tramex Concrete Moisture Encounter over bare concrete with no adhesive or sealer.
- Less than 8 pounds per 1000 sq. ft. per 24 hours when using Calcium Chloride test (ASTM F1869).
- 85% max. when using Relative Humidity Testing (ASTM F2170).

NOTE: Concrete moisture content may be acceptable the time of the test. These tests do not guarantee a perpetual "dry" concrete slab. The concrete slab moisture content can vary at other times of the year. We are not responsible for moisture-related damage to installed flooring.

WOOD SUBFLOOR REQUIREMENTS

The subfloor must be clean; no presence of construction debris, soil, mud and any other objects on or adhering to the floor; no protrusions of nails, debris, or metals should remain. If necessary, scrape and sweep the subfloor before the installation.

The subfloor must be structurally sound and stable; no movements or squeaks; no loose panels or loose nails; no signs of ply de-lamination or other damages. Repair all shortcomings before installation.

The subfloor must be flat; no visible bumps or low spots; the subfloor should be flat to within 3/16 in. in 10 ft. span. Test for moisture using a reliable pin type meter. Perform tests at locations around exterior doorways, near foundation walls, near walls containing plumbing lines and in the center of the room. Moisture levels should not exceed 14%.

PLYWOOD OR ORIENTED STRAND BOARD (OSB) SPECIFICATIONS

On truss/joist spacing of 16 in. (406 mm) O/C or less, the industry standard for single-panel subflooring is a minimum 5/8 in. (19/32 in., 15.1 mm) CD Exposure 1 plywood subfloor panels (CD Exposure 1) or 23/32 in. OSB Exposure 1 subfloor panels, 4 ft. x 8 ft. sheets. Expansion gap between panels should be 1/8 in. (3 mm). If panels are not tongued and grooved and there is not sufficient spacing or is inadequate, cut in the required spacing with a circular saw. Do not cut in expansion space on tongue and groove panels.

PARTICLE BOARD OR FIBER BOARD

Only for floating installation. Product has to be sound and stable with no visible signs of moisture-related conditions.

EXISTING FLOORS

Approved subfloors include concrete, plywood, OSB, particleboard, chipboard, hardwood (solid, engineered, parquet), tile (ceramic, terrazzo, stone, asbestos, peel and stick), non-cushion sheet vinyl, metal, VCT, DRIcore.

Adhered and sound vinyl sheet goods, linoleum and resilient (VCT) tiles: Old vinyl and linoleum tiles or sheet goods normally do not need to be removed if they are fully bonded and free of any notable damage. Some older vinyl sheet goods and tile contain asbestos. Should it contain asbestos special precautions must be taken for your safety. Contact a professional immediately for inspection and removal.

Ceramic tiles and terrazzo: Old flat ceramic tiles normally do not require removal. Grout joints wider than 1/16 in. must be filled. Usually, HDC Plank products can be installed directly over ceramic tiles and terrazzo providing they are fully adhered, smooth, sound and dry. These flooring materials must be smooth and flat to within 1/4 in. in a 10 ft. radius and must not vary more than 1/16 in. when measured with a 3 ft. straight edge.

Do not install over more than one layer of vinyl.

Non-approved subfloors include carpeting/carpet pad, cushioned vinyl flooring, floating floors, laminate, parquet over concrete, cork, engineered hardwood over concrete, sleeper substrates, hardwood over concrete and rubber. Remove these floors and old adhesive before installing new flooring.

JOB SITE CONDITION

Prior to installation, the installer must ensure that at the time of installation, the job site conditions including subfloor/substrate, ambient temperature and relative humidity, and all impacting variables will not negatively affect the floor. The manufacturer will decline responsibility for damages associated with improper installation or poor site conditions.

STORAGE AND CONDITIONS

Acclimate the flooring a minimum of 24 hours before installation in the area it is to be installed. Conditions between 50°F and 100°F (10°C and 37°C) are required before, during and after installation. Cartons should be evenly stacked no more than five high on a flat surface and away from any heating/cooling ducts or direct sunlight.

EXISTING HOME

An existing home should have a consistent room temperature between 50°F and 100°F (10°C and 37°C) and relative humidity (RH) of 35%-85%. Continual deviation from these conditions will affect the dimensions of flooring. When using a heater during winter months, humidity may be much lower than the acceptable range. During the warmer months, maintain humidity levels using an air conditioner, dehumidifier, or by turning on your heating system periodically.

NEW CONSTRUCTION OR REMODEL

All work involving water, such as pouring basement concrete floors, drywall and plasterwork, plumbing, etc. must be completed well in advance of the floor delivery. Ensure that the building is enclosed. Where building codes allow, permanent heating and/or air conditioning systems should be operating at least two weeks preceding installation and should be maintained during and after installation. If it is not possible for the permanent heating and/or air conditioning system to be operating before, during and after installation, a temporary heating and/or dehumidification system that simulates normal living (occupied) conditions can enable the installation to proceed until the permanent heating and/or air conditioning system is fully operational. Your job site should have a consistent temperature between 65°F and 85°F (18°C and 29°C) and relative humidity (RH) of 35%-85% which should be maintained continuously thereafter.

RECOMMENDED INSTALLATION AREA

Do not install vinyl planks/tiles over carpet or any foam underlayment. This product is not suitable for any outside use, sunrooms/solariums, saunas, seasonal porches, camping trailers, boats, RV's or rooms that have a potential of flooding. Do not install in rooms or homes that are not temperature controlled. Exposure to long term direct sunlight can cause damage to your floor. Failure to properly shade or UV tint windows can discolor, fade, or buckle vinyl planks/tiles. Use window treatments or UV tinting on windows. This flooring is a floating floor and should be allowed to expand and contract freely. It must be glued, nailed, or fastened to the subfloor in any way. Permanent cabinets, vanities, islands and similar items should be installed first. Then, install this flooring around them, leaving the proper expansion gap. This flooring can be installed under vanities with legs as well as under toilets; leave proper expansion space around the flange and use a premium waterproof 100% silicone caulk. Do not anchor toilet through the material.

This product is a waterproof floating floor, but it should not be used to seal an existing floor from moisture. It cannot inhibit the growth of mold or prevent structural problems associated with, or caused by flooding, excessive moisture, alkalis in the subfloor, or conditions arising from hydrostatic pressure. Regardless of location, always remove standing water, urine and other liquids promptly. Job site moisture issues should be addressed and corrected prior to installation. Fill expansion spaces around potential wet areas only with premium waterproof 100% silicone caulk.

BASEMENTS AND CRAWL SPACES

Concrete slab or ground must be dry. Ensure that crawl spaces have open vents year round to ensure proper air circulation and prevent moisture build up. The ground in the crawl spaces must be completely covered using 6 mil black polyethylene. Crawl space clearance between the earth and underside of joists should be no less than 18 in. and the perimeter vent area should be equal to 1.5% of the total square footage of the crawl space or as mandated by code.

RADIANT HEATED SUBFLOOR

If considering Radiant heat, only Hydronic radiant heat can be used. The heating components must have a minimum of 3/8 in. separation from the product. System must be operational for a minimum of two weeks prior to installation. Five days prior to installation, the temperature should be reduced to 65°F (18°C). After installation, the temperature can be raised gradually (5°F per hour) to a maximum operation temperature of 85°F (29°C). An in-floor thermostat is recommended to avoid overheating. A transition strip must be used for any installation longer than 40 linear feet and/or wider than 30 linear feet. It is also suggested to use T-Molding in doorways.

MOISTURE BARRIER/UNDERLAYMENT PADDING

CONCRETE SUBFLOOR

When installing over a crawl space or concrete slab, it may be necessary to use a moisture barrier to prevent moisture migration. A plastic film with a minimum thickness of 6 mil should be placed with a 4 - 6 in. (101.6 - 152 mm) overlapped seam, and taped with a suitable tape.

EXPANSION GAP

A required gap width of 1/4 in. is required around the perimeter of the floor and between the floor and all vertical obstructions. Do not place permanently mounted structures such as kitchen counters/cabinets on the installed floor.

TOOLS AND MATERIALS BASICS

Tape measure, Utility knife, Eye protection, Gloves, Tapping block, Soft-faced hammer, Pull bar, 1/4 in. spacers, Level, Reciprocating saw (optional), Miter or circular saw (optional), Knee pads (optional).

Helpful Pointers

GENERAL TIPS

- Make sure your work area is well lit. Good visibility ensures that color is consistent and that visually defective planks/tiles are detected and removed.
- The minimum length of the first and last plank/tile is 8 in.. If the last plank/tile will be less than 8 in., adjust the length of the first plank/tile. The remainder of the last plank/tile can be used as a starter board on the following rows.
- Using a shorter piece at undercut door jams will help when fitting flooring in place.

IMPORTANT: Never hit the flooring directly with a tapping block and be careful not to fracture flooring edges.

- For plank installation, we recommend staggering the end joints a minimum of 6 inches.
- For tile installation, we recommend staggering the end joints a minimum of 3 inches.

NOTE: Do not install four corners together, as this will not provide a stable installation.

CUTTING THE LAST ROW TO WIDTH

- Most often the entire length of the last row will need to be cut so that it is narrow enough to fit the remaining space.
- Measure the distance between the floor face edge (exclude the tongue) to the wall. Subtract 1/4 in. from this measurement for expansion gap. Draw a line. Cut through the line. Discard the excess piece. Proceed with the installation.

Preparing for Installation

- Ensure subfloors are clean.
- Lay out several cartons. Randomly rack the flooring planks/tiles to ensure good color and shade mixture and end joint spacing. Minimum end stagger is 8 in. Inspect plank/tile quality and grading.
- Lay out trim moldings in advance and find flooring pieces whose shade closely matches. Set these aside for future use.
- Remove the existing base, shoe molding or threshold carefully. They can be used to cover the 1/4 in. expansion gap left around the edge of the room.
- Undercut doors and casings using a handsaw laid flat on a piece of scrap flooring. Never undercut metal door casings.

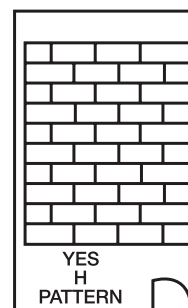
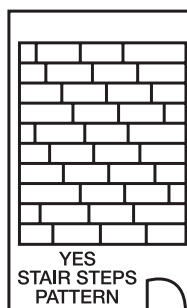
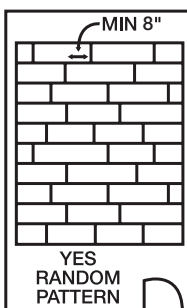

Installation

1. INSTALLING THE FIRST ROW

- It is recommended that installation begin in a corner of the room. Between the first row of flooring and the wall, insert spacers so that a 1/4 in. (6 mm) gap is created.
- When installing the first row, insert the short edge of one plank into the short edge of another plank at a slight angle and rotate downward. Continue to complete the starter row maintaining a straight edge for the following row.
- Use a tapping block and soft faced hammer to close any gaps between the planks.
- Once you reach the end of the first row, measure and cut the final plank so that it completes the row while also leaving the necessary 1/4 in. expansion gap. Last planks of rows must be at least 8 in. long.

NOTE: Use a spare plank to create a straight edge at the cut line. Use a utility knife to score the top of the pattern and snap the panel. It will be necessary to cut the foam underlayment after snapping the panel.

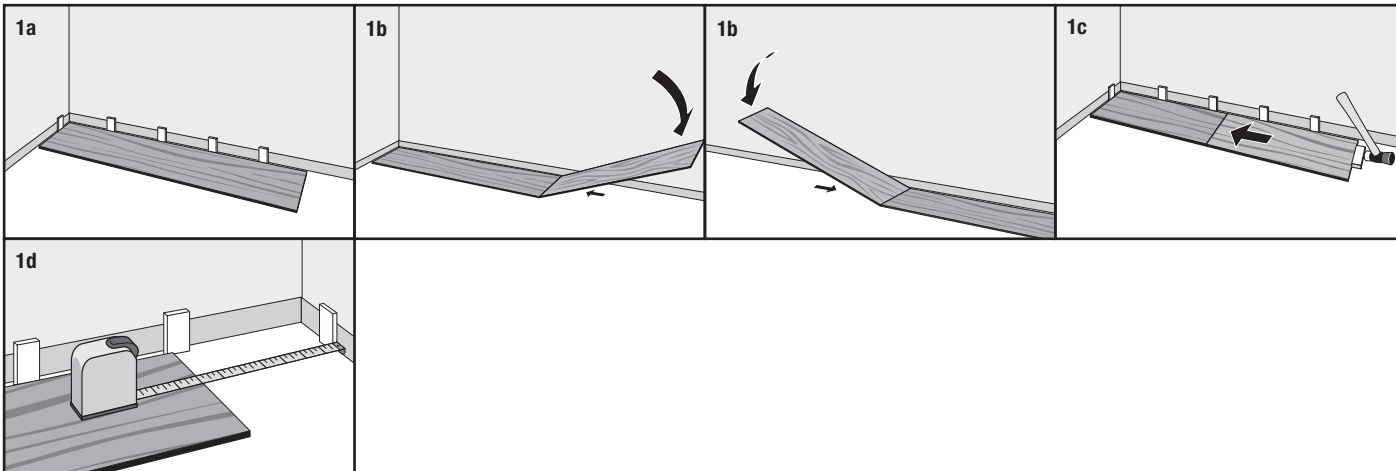

2. INSTALLING THE SECOND AND REMAINING ROWS

- Start the second row of flooring by using the trimmed planks from the previous row. First pieces must be at least 8 in. long. End joints should be staggered a minimum of 6 in.
- At a slight angle, insert the long edge tongue of the first plank in row 2 into the long edge groove of the plank in row 1 until the plank edges meet, and then rotate down until the joints lock.
- When joining the next plank to the first plank in the row, join the short side edges first. There will be a gap on the long side joints when the plank is rotated down.
- Raise the outside long edge of the plank upward approximately 1 in. Maintain this angle as you push the plank in until the long edge of the plank meets the long edge of the first row. Rotate downward on the plank until the joint locks.
- After tapping the long side joint closed, close the short edge joints using a tapping block or pull bar.
- Repeat these steps to complete the installation.
- After each row is complete, ensure there will be a 1/4 in. (6 mm) gap (after the joints are closed) to the wall for expansion.

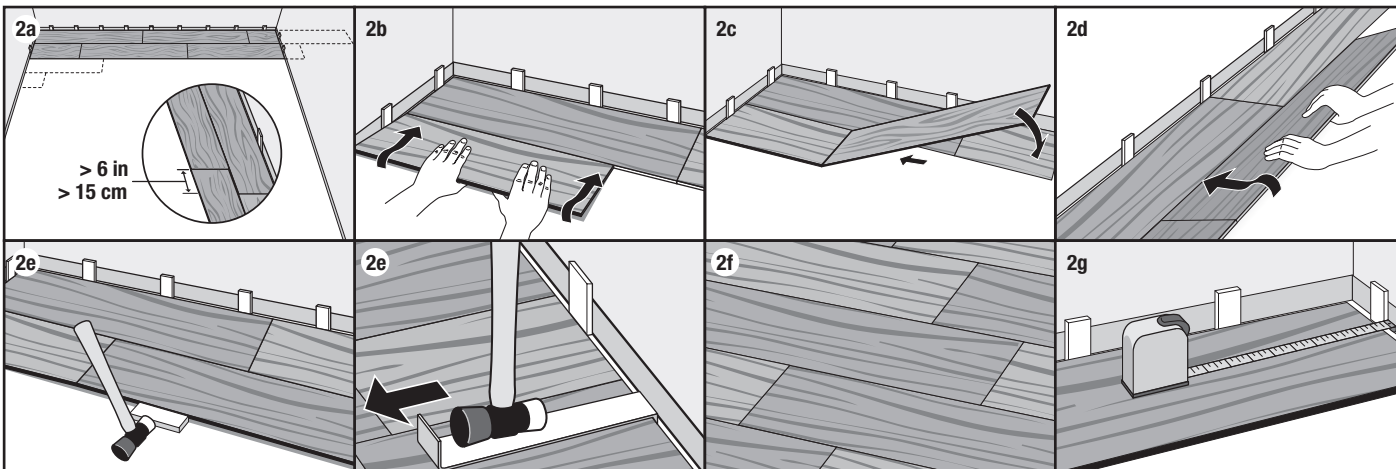

3. INSTALLING THE LAST ROW

- For the last row, align the plank to be used on top of the 2nd to last row. Using a full width plank as a spacer, trace the wall contour. Use a full plank as a straight edge to cut the plank. Insert the long edge tongue into the long edge groove and use a pull bar and hammer to close the gap.
- After tapping the long side joint closed, close the short edge joints using a tapping block or pull bar.

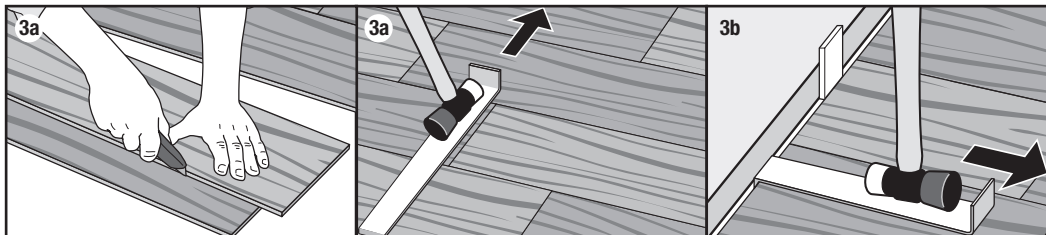

4. INSTALLING UNDER DOORWAY FRAMES

- When the new flooring meets a threshold or a doorway, we recommend undercutting the door jamb. To secure the right cut, turn a plank upside down and place it on the floor up to the door frame. Then place a reciprocating saw flat against the plank and simply cut through the frame. Remove the cut-out piece and vacuum away debris. Slide the plank under the pre-cut door frame. Door frame should be cut so that a 1/4 in. (6 mm) gap is located from the edge of the plank under the casing to the wall.
- Tap the long side joint closed first, then tap the end joint closed.

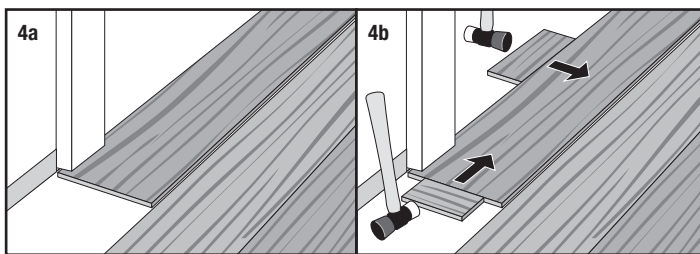

5. INSTALLING AROUND FIXED OBJECTS

- Allow 1/4 in. (6 mm) expansion space around pipes or other fixed objects.
- In rows where there is a pipe, make sure the pipe falls exactly in line with the short side of two planks. Select a drill bit with the same diameter as the pipe plus 1/2 in. (13 mm). Click the planks together on the short side and drill a hole centered on the joint between the two planks. Then install the planks.
- For a double pipe, drill a hole equivalent to the diameter of the pipe plus 1/2 in. (13 mm) at each of the marked points. If located on the long side of the plank, make a 45° cut from each hole to the edge of the plank. Then, using an appropriate glue along the cut edges of the piece you cut out, glue the piece in place. Be sure no glue comes between the cut-out piece and the subfloor.

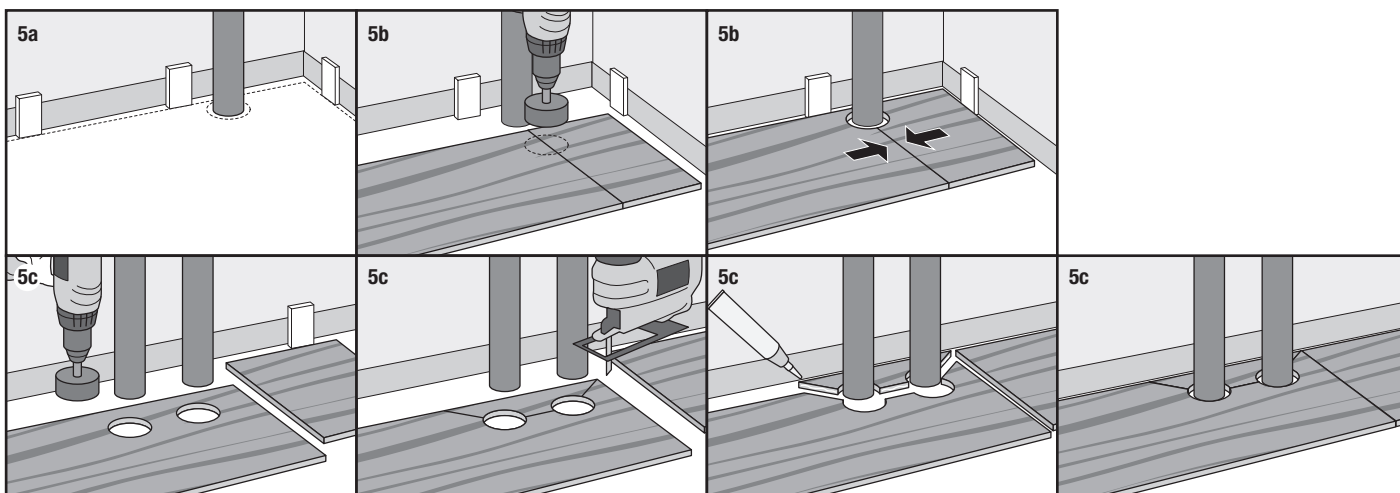

6. FINISHING THE INSTALLATION

- Remove all spacers.
- Fill any expansion spaces around potentially wet areas (such as refrigerators, tubs, etc.) with premium, waterproof 100% silicone caulk.
- Remember, the use of coordinating T-Molds is required when installing flooring in a room or area that is larger than 100 lineal feet (30.5 meters) in any direction, so that the floor is separated into sections that are no larger than 100 ft. x 100 ft. (30.5 meters x 30.5 meters) per section.
- Install moldings to cover the expansion gap. When installing moldings, never allow nails or screws to enter the flooring or the expansion zone around the flooring perimeter. All moldings and transition strips need to provide a 1/4 in. (6 mm) expansion space as well.

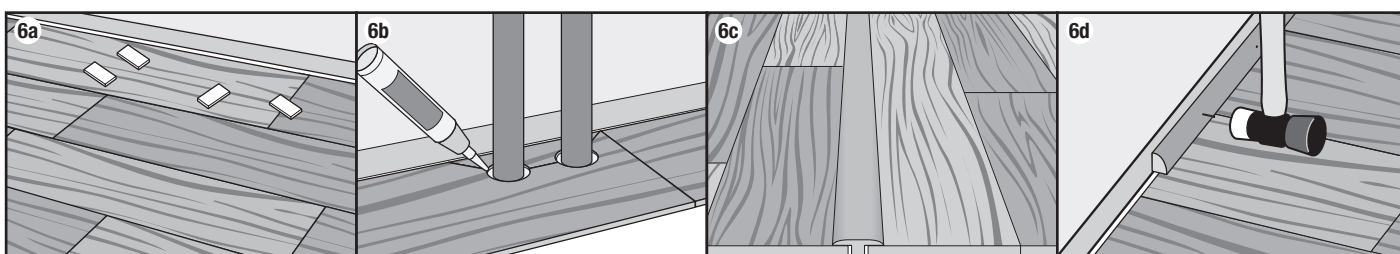

Note: Coordinated moldings can be purchased on homedepot.com. Follow molding installation instructions for proper installation.

NOTE: Rooms larger than 1500 sq. ft. (50 ft. x 30 ft.) require the use of coordinating T-molding transitions. Doorways and archways less than 4 ft wide also require the use of T-molding transitions.

NOTE: Save any leftover planks/tiles. Do not discard as they are color matched (dye-lot) to your floor. They can be used for replacement in the event you need to replace a plank/tile in the future.

Accessories

Pictures are for general illustrative purposes only. Actual products may differ from pictures.

- Clean the floor.
- Install or reinstall all wall trim pieces. Nail them through the wall, but not to the subfloor to avoid restricting the expansion gap.
- Install transition trim pieces. Nail them to the subfloor, not the flooring.
- At doorways, transitions should be used to protect the edges of the floor and to provide a decorative transition from one floor type to another.
- If the floor is to be covered, use a breathable material such as cardboard. Do not cover with plastic.

T-Molding: Used to create a transition between floor coverings of similar heights or to cover an expansion gap.

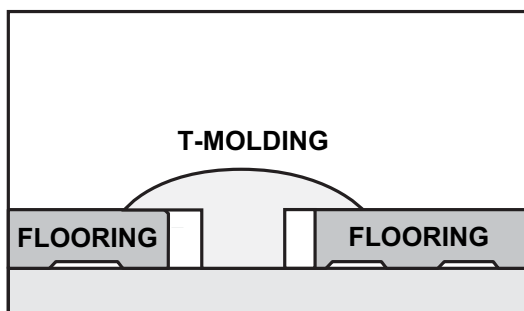

Stair Nose: Used in conjunction with flooring installed on stair steps or finished edges of a higher level floor like in a sunken living room.

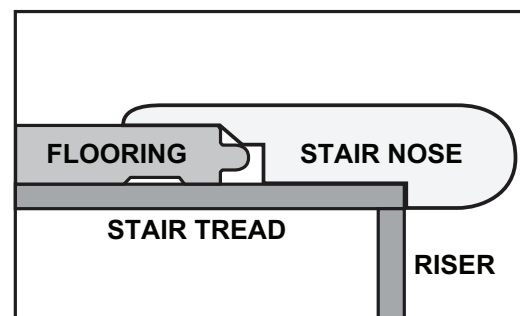

Hard Surface Reducer: Used to transition to another hard surface flooring of different heights such as tile, vinyl, or concrete.

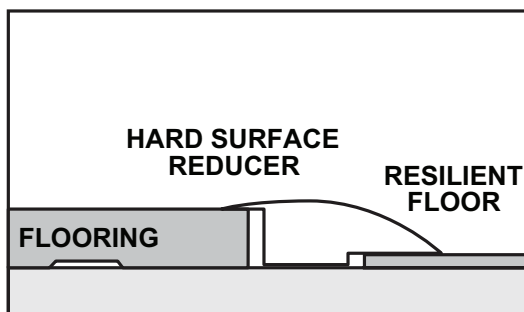

Quarter Round: Used to cover the expansion space between the wall base and your flooring. It can also be used to make smooth transitions between the floor and cabinetry. It can be used with or without wall base molding. Ensure you nail the quarter round to the wall and not the flooring, as shown.

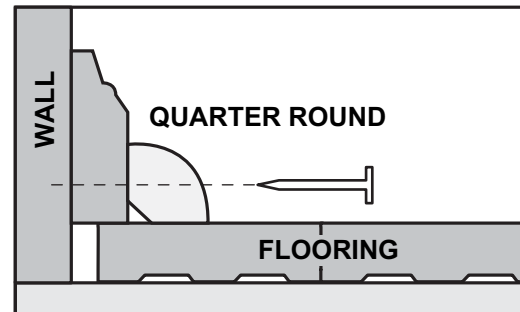

Care and Maintenance

DAILY MAINTENANCE

- Sweep, dust, damp mop, or vacuum your floor regularly to remove any particles that could cause abrasion or scratch your floor.

CAUTION: Vacuums with a beater bar or power rotary brush head can damage a floor and should never be used.

- Use a damp mop to remove spots and soil. Use any high-quality, pH-neutral vinyl cleaner. Alternatively, use a non-rinsing, biodegradable cleaner that leaves no residue or haze.
- Do NOT use detergent based cleaners.
- Do NOT use an abrasive mop and shine products.
- Do NOT use ammonia or bleaches.
- Do NOT use steel wool or scouring powder which will scratch the floor.
- Do NOT use any dust cleaners, as they may cause your floor to become slick or damage the finish.
- Avoid spills of paints, dyes, or harsh chemicals.
- Avoid long term exposure to direct sunlight. Use window treatments or UV tinting on windows.

BRANDED OR OFF-THE-SHELF FLOOR CARE PRODUCTS

If none of the above are effective and you choose to use a store bought product, test the product in a non-conspicuous area (i.e., closet, corner, or scrap pieces) for potential adverse side effects.

PREVENTATIVE MAINTENANCE

- Protect your floor when using a dolly for moving furniture or appliances. Protective sheets and/or plywood may be needed. Never slide or roll heavy furniture or appliances across the floor.
- Use flat floor protectors (nylon or felt) on all furniture legs. Clean protectors periodically to remove grit that may become embedded and cause scratching.
- Avoid excessive exposure to water from being tracked in during periods of inclement weather.
- Minimize abrasive material and dirt by placing mats on both sides of exterior doors and by using area rugs in high-traffic areas
- Rearrange furniture and rugs periodically to avoid uneven color and shade changes from light exposure.
- Use protective mats beneath rolling chairs and keep furniture casters clean.
- Use NON-RUBBER backed mats at all entrances to reduce the walk-off residue from asphalt driveways as well as prevent dirt and grit from being tracked onto your floor. Rubber backed mats can discolor your floor.
- We recommend the use of a hard surface (non-studded), non-rubber chair mat to protect your floor from office chairs with casters. Light, rolling furniture should be outfitted with broad-surface, non-staining casters that have been engineered for hard surface floors. Such casters should be a minimum of 1 in. (2.5 cm) wide and at least 2 in. (5.1 cm) in diameter.
- Keep pets' nails trimmed.
- Remove shoes with cleats, spikes or exceptionally pointy heels before walking on the floor.