

GE Infrastructure  
Water and Process Technologies

Merlin™  
Point of Use  
Drinking Water System

Installation and Maintenance Manual





## SAFETY GUIDES

Read and follow all steps and guides carefully before installing and using your reverse osmosis system.

Do not use this product to make safe drinking water from non-potable water sources. Do not use the system on microbiologically unsafe water, or water of unknown quality without adequate disinfection before or after the system.

This reverse osmosis system contains replaceable components (membrane elements). These components are critical for the effective reduction of total dissolved solids and specific contaminants that are listed in the Product Data Sheet.

The Merlin drinking water system does not have a monitoring device for contaminants. To verify that the system is performing satisfactorily the product water should be tested periodically by the system's installing dealer or a certified laboratory, every six months. The laboratory should be certified for testing the specific contaminants of concern. For a listing of certified laboratories, contact local regulatory agencies. Within the United States, many state-run Department of Natural Resources or Department of Health Services maintain listings of certified laboratories.

The included nitrate/nitrite analysis strip may be used to determine concentration of nitrate and nitrite in the product water. The test should be performed every six months according to instructions included with the strip. Allow the product water to run continuously for two minutes prior to testing. Additional nitrate/nitrite analysis strips may be obtained from your installing dealer. See back cover of this manual for the installing dealer's contact information.

Consult your local public works department for plumbing and sanitation codes. Follow your local codes if they differ from this manual.

The reverse osmosis system works on water pressures of 40 psi (2.8 bar) minimum to 80 psi (5.5 bar) maximum. Water pressure can be reduced by installing a pressure reducing valve in the water supply pipe to the RO system. A booster pump should be used for low pressure applications.

Do not install the reverse osmosis system in extreme hot or cold temperatures. Temperature of the water supply to the reverse osmosis system must be between 40°F (4°C) and 100°F (38°C). Do not install on **hot** water lines.

The reverse osmosis membranes contain a foodgrade preservative for storage and shipment. **New membranes should be flushed for one hour prior to use.** This flush removes the preservative. The preservative is not harmful but makes the product water taste objectionable.

## THE BASIC REVERSE OSMOSIS SYSTEM

Your Merlin™ Reverse Osmosis (RO) Drinking Water System is a water treatment unit. It uses water pressure to reverse a natural physical process called *osmosis*. Water, under pressure, is forced through a semi-permeable membrane to filter out minerals and impurities. Treated drinking water goes to the faucet. Minerals and impurities are sent to the drain with RO waste water.

The system includes replaceable filters and membrane elements. The prefilter reduces sand, silt, dirt, rust particles, other sediments, and chlorine from the water supply before they enter the RO membrane elements. The postfilter reduces any tastes and/or odors that may remain in the water after passing through the RO membrane elements.

### BEFORE INSTALLING THE RO SYSTEM

- Best performance of the system will be achieved when the incoming water has been treated (softened).
- The water coming into the system must be within certain limits for sediments, pressure, etc. Refer to the specifications to determine if your installation is within the limits.
- A water quality analysis can be performed to determine if incoming water requires any treatment. Contact your dealer/installer.
- The filters and membrane elements in the RO system need to be replaced on a regular basis. Follow the instructions for replacement that are in this manual.
- The faucet options for the Merlin RO have not been tested or certified by the Water Quality Association. It is recommended that faucets meeting National Codes be used.
- The feed pressure gauge supplied with some Merlin RO systems has not been tested or certified by the Water Quality Association. It is recommended to remove the feed pressure gauge during normal system operation.



**NOTE:** For optimal system performance, use the system for at least 2 minutes continuously each day.



**WARNING:** The Merlin RO system is designed to work without the aid of a pressurized storage tank. Installation of a pressurized storage tank will negatively affect system performance.

# MERLIN COMPONENTS

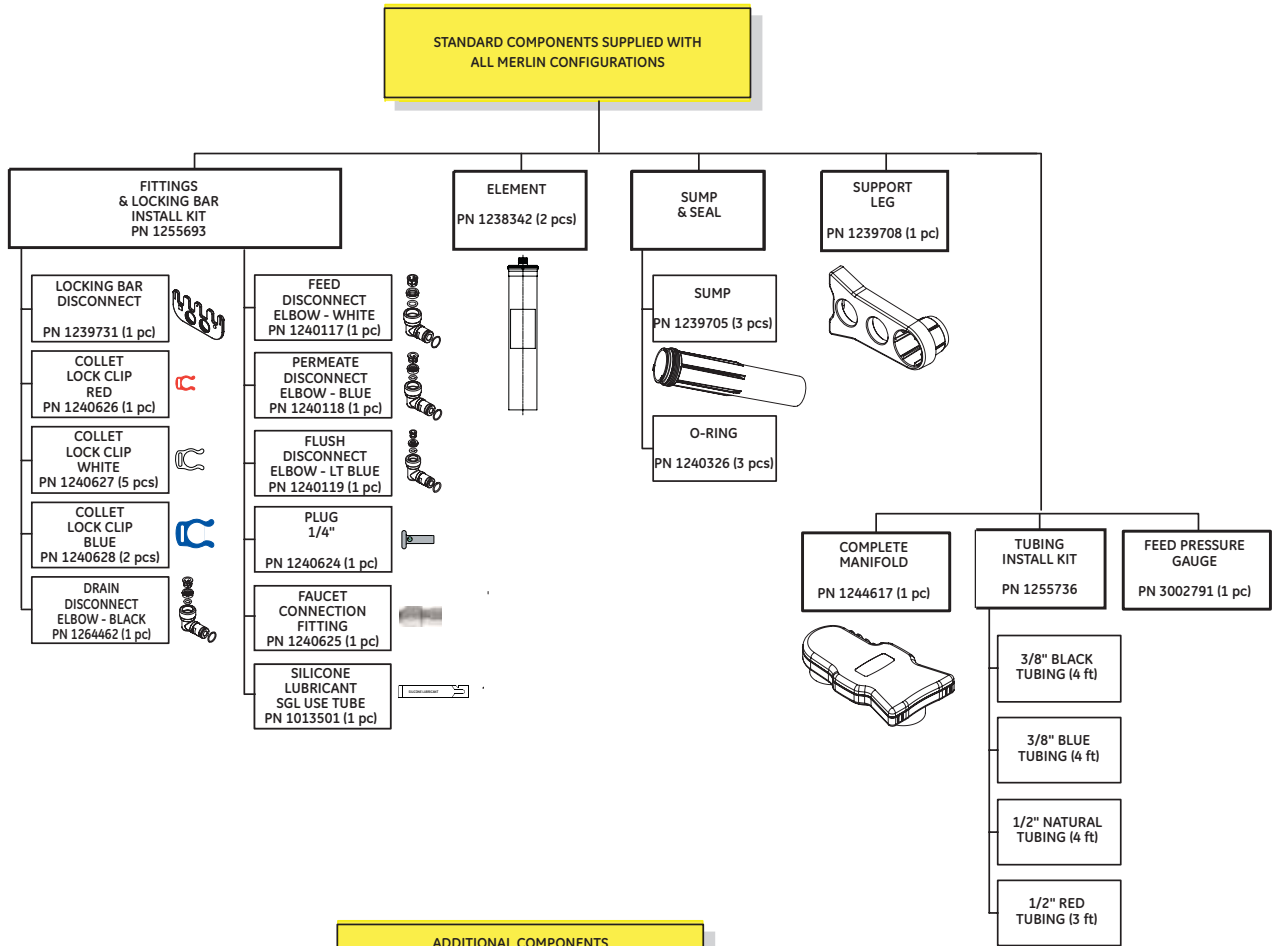

## ADDITIONAL COMPONENTS (see table below)

- CARBON PRE-FILTER**  
 PN 1237460 (1 pc)
- SEDIMENT PRE-FILTER**  
 PN 1266690 (1 pc)
- CARBON POST-FILTER**  
 PN 1244746 (1 pc)
- ASO CARTRIDGE**  
 PN 1269491 (1 pc)
- DRAIN BOA KIT**  
 PN 1240564 (1 pc)
- AIR-GAP FAUCET KIT**  
 PN 1254894 (1 pc)

Note: For use with chlorinated water supplies.

Note: For use with non-chlorinated water supplies.

Note: For use without a carbon postfilter installed.



NAME	MERLIN PN*	AGENCY CERTIFICATION	CARBON PREFILTER	SEDIMENT PREFILTER	CARBON POSTFILTER	ASO CARTRIDGE	DRAIN BOA KIT	AIR GAP FAUCET KIT
Merlin I	1255052	YES**	Included	-	Included	-	Included	Included
Merlin II	1263870	YES**	Included	-	Included	-	Included	-
Sediment w/ faucet	3002041	NO	-	Included	Included	-	Included	Included
Sediment w/o faucet	3002044	NO	-	Included	Included	-	Included	-
Light commercial	3002043	NO	-	Included	-	Included	-	-

\*Includes all "Standard" components.

\*\*See Performance Data Sheet included with Merlin for Certification Information.

## LOCATION OF SYSTEM

The reverse osmosis system is designed for installation under a sink, usually in the kitchen or bathroom. The RO assembly can be placed on the cabinet floor in any position that does not apply pressure on the disconnect elbows. The RO product water faucet installs on the sink or on the countertop next to the sink.

The RO system can also be located in a location away from the faucet. A nearby water source and drain point are required.



**NOTE:** Keep the lengths of tubing short. Longer lengths of tubing will decrease system performance. A booster pump can be used on the supply line.



**NOTE:** All plumbing should be done in accordance with state and local plumbing codes. Some codes may require installation by a licensed plumber. Check with the local plumbing authority prior to installation.



**WARNING:** All components and tubing should be located in an area which is not exposed to freezing temperatures. Do not expose unit or tubing to direct sunlight.

**Water Supply:** To provide supply water to the RO system inlet, a feed supply fitting is required or install pipe fittings as needed. The feed water valve should be located as close to the manifold assembly as possible. USE A POTABLE COLD WATER SUPPLY ONLY. Softened water is preferred as it will extend the life of the RO membrane element.

**Drain Point:** A suitable drain point is needed for reject water from the RO system. A floor drain, laundry tub, standpipe, sump, etc. are all acceptable. If discharging into the utility sink or standpipe, an air gap of greater than 1.5 inches above the flood rim must be provided. A sink p-trap drain adapter is included to install as an optional drain point where codes permit.

Do not connect the system drain line to the dishwasher drain or near the garbage disposal. Back pressure from these units may cause the air gap to overflow.

**Dispensing Faucet:** The faucet should be placed near the sink where drinking water is normally obtained. Convenience of use (filling of water pitchers and glasses) and an open area beneath the faucet under the sink for attaching product and drain tubing are considerations. A 2-inch diameter flat surface is required above and below the installation site. The thickness of mounting surface should not exceed 1-1/4 inches. Avoid any strengthening webbing on the underside of the sink.

**RO Manifold Assembly:** The manifold can be installed on either the right or left side of the under-sink area or cabinet. Installation in the basement is also an option. One possible location is near the laundry/utility sink where cold potable water and drain access are close. The location chosen should allow adequate clearance and accessibility for membrane element changes.

**Optional Flush Kit:** The flush kit, if used, should be placed within 6 feet of the manifold assembly. This will minimize pressure drop and allow the flush system to operate most efficiently.

In restricted under-sink areas, it may be easier to install the faucet first. Allow adequate tubing lengths for final system placement.

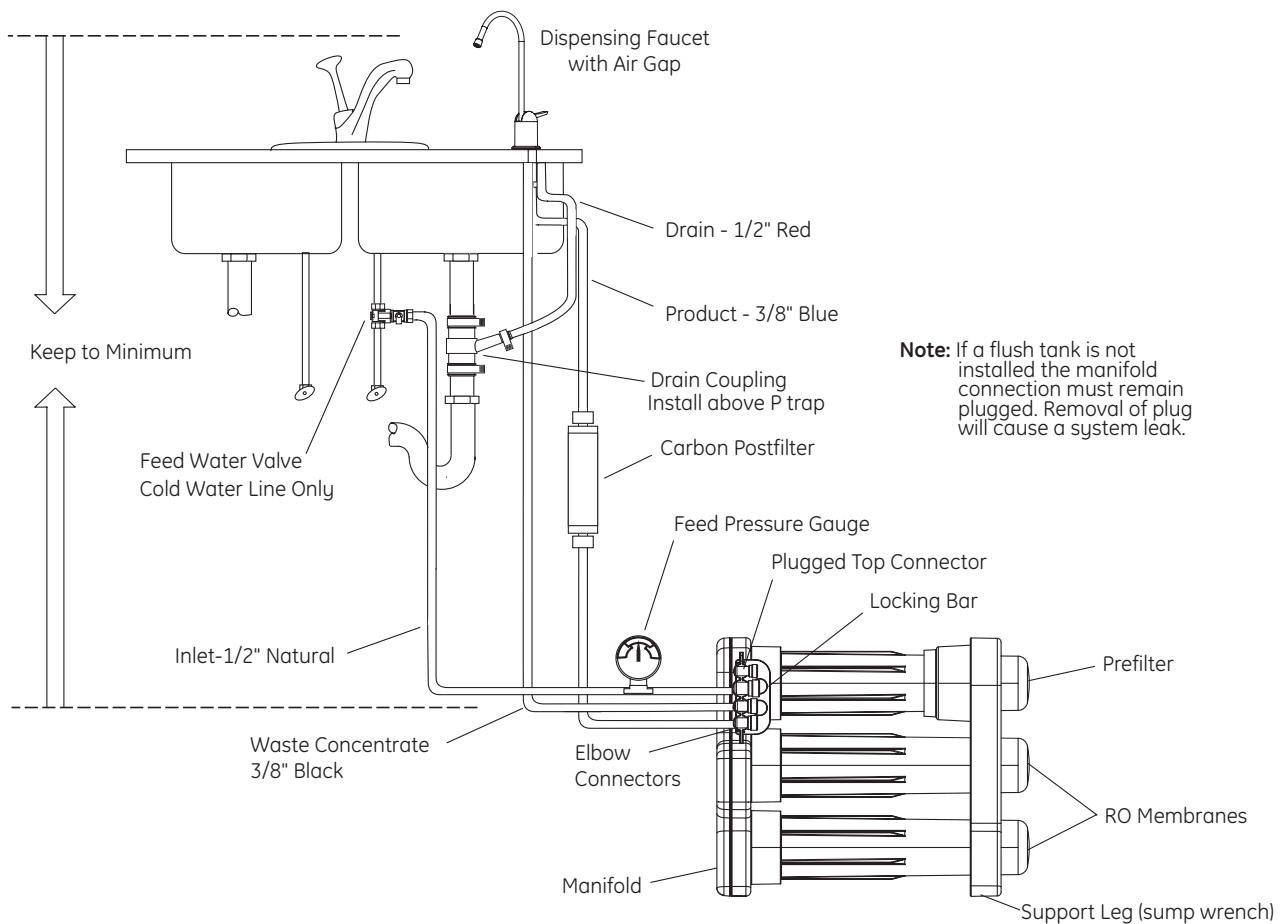

Figure 1 Typical Under-Sink Installation

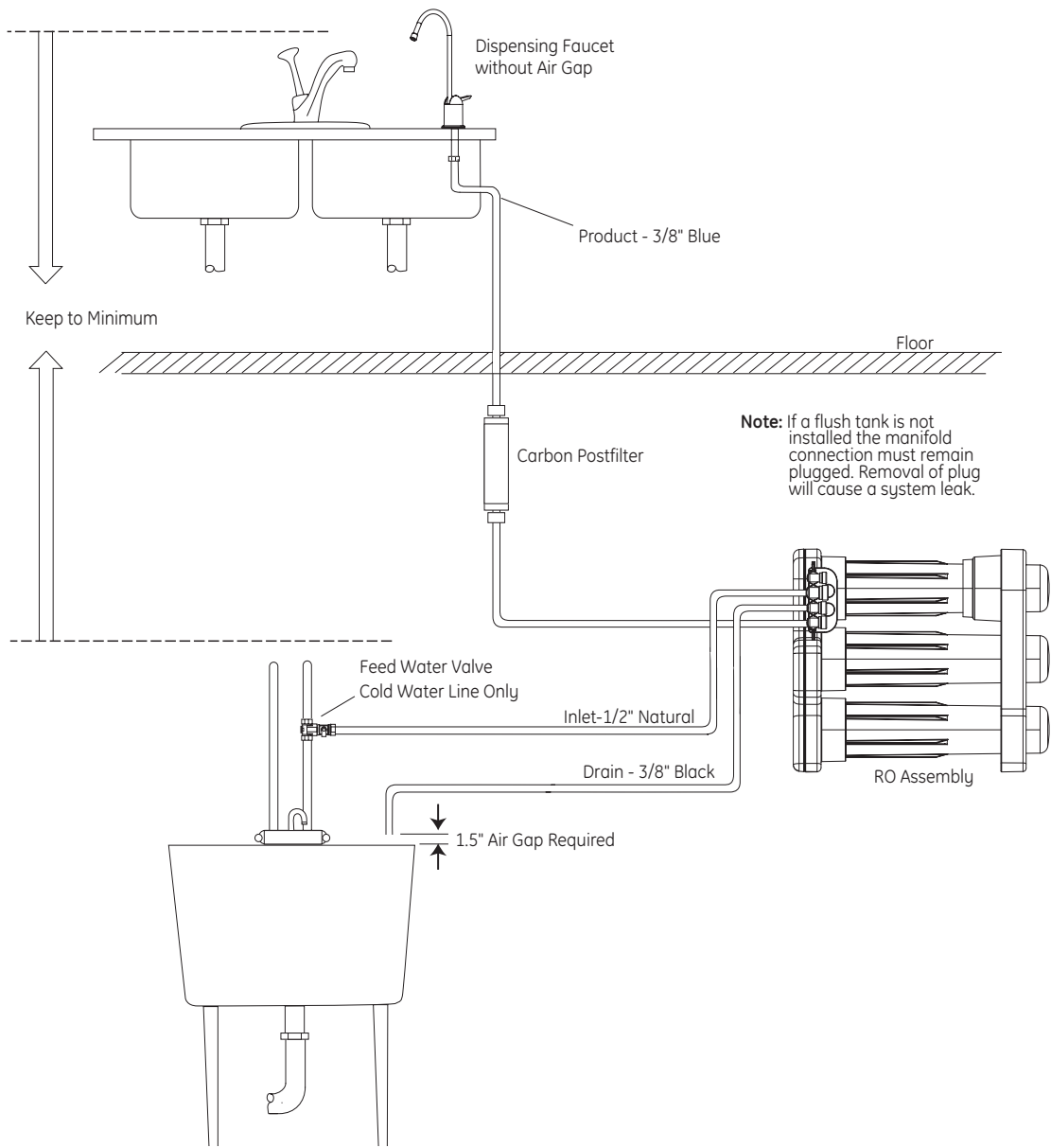

Figure 2 Typical Basement Installation



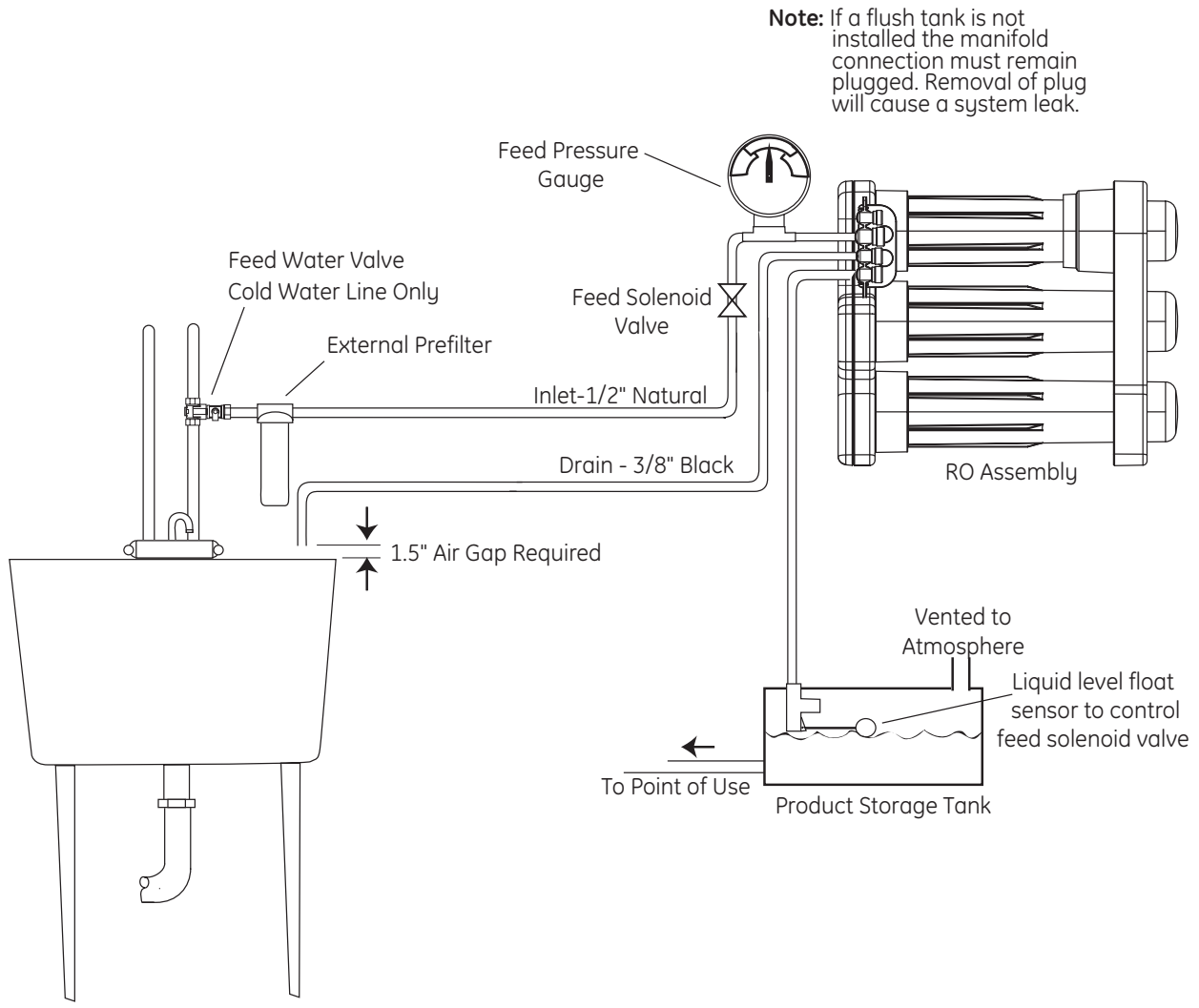

Figure 3 Typical Light Commercial Installation

## REQUIRED TOOLS AND MATERIALS

- Adjustable wrench, and larger adjustable jaw pliers or pipe wrench to fit sink drain
- Saw for cutting drain pipe
- Slotted and Phillips head screwdrivers
- Tubing cutters
- Electric drill and bits for cutting the faucet mounting hole

Note that some sinks will have a pre-drilled hole with a plug for the faucet.

## INSTALLATION

STEP 1: Install cold water supply valve

STEP 2: Install drain adapter

STEP 3: Install faucet

STEP 4: Make tubing connections

STEP 5: Install RO assembly

STEP 6: Put system into operation



**NOTE:** Consult a licensed plumber if you are not familiar with plumbing procedures.

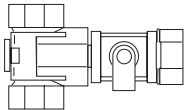

### STEP 1: INSTALL COLD WATER SUPPLY VALVE

Comply with local plumbing codes. A typical connection using a water supply valve is shown.

## Water Supply Valve



**NOTE:** Be sure to turn off the water supply and open a low faucet to drain the pipe.

Cold water pipes vary in size and style. The installer will determine type of valve that will be used. Install a valve on the cold water supply pipe to adapt 1/2-inch OD tubing. If threaded fittings are used, be sure to use pipe joint compound or Teflon tape on outside threads.

Turn the valve off.

## STEP 2: INSTALL DRAIN ADAPTER

Follow the instructions in the Appendix for installation of the Drain Boa™, if used.

The drain adapter is designed to fit 1-1/2-inch (3.8 cm) sink drain pipe.

The adapter installs directly to the sink tailpiece.

## STEP 3: INSTALL FAUCET

### A. Prepare Mounting Hole

1. Select a location for the faucet. Be sure it will fit flat against the sink or counter and that there is space underneath for tubing.
2. If drilling is needed, make a 1-1/2 inch diameter hole. If the air gap module is not being used, a smaller diameter hole is acceptable.



**WARNING:** To avoid damaging a sink, consult a qualified plumber or installer for the proper method of drilling holes in porcelain or stainless steel.

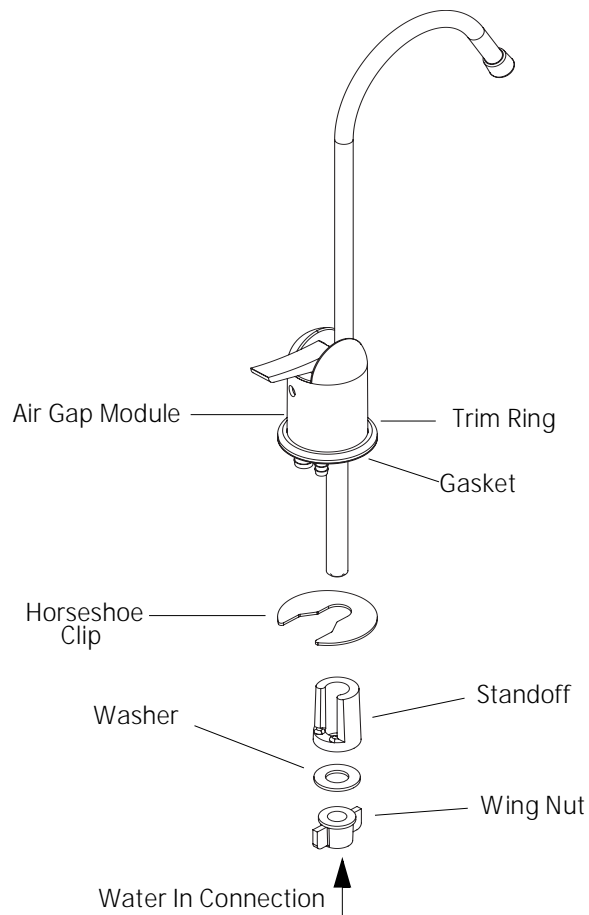

Figure 4

## B. Assemble Faucet

The tubing and fasteners are assembled to the faucet before the faucet is placed in position. This can be done above the sink.

1. Slide the decorative ring over the tubing connections and up to the bottom of the faucet.
2. Slide the gasket over the tubing connections and up to the bottom of the faucet.
3. Slide the standoff onto the threaded tube, followed by the standard washer and nut.
4. Screw the threaded hose connector on the end of the threaded tube.
5. Connect the blue 3/8-inch product tubing by firmly pushing it into the connector.
6. If using the air gap module, push the black 3/8-inch tubing onto the small hose barb. The red 1/2-inch tubing is pushed onto the large hose barb.
7. Put the faucet into position.
8. The horseshoe clip is positioned around the threaded pipe under the sink and above the standoff. This clip should engage the tubing connected to the air gap, if used.
9. Tighten the nut against the clip to hold the faucet in position.

## STEP 4: MAKE TUBING CONNECTIONS

The connections to the faucet should be complete, the remaining connections are:

- Feed connection—clear tubing from feed valve to white elbow connector
- Drain connection—either red tubing from the air gap or black tubing from grey elbow connector will attach to the drain adapter
- Permeate connection—blue tubing from faucet to blue elbow connection
- To the flush tank (if used)
- Attach the fittings to the manifold

A typical connection is shown in Figure 5.

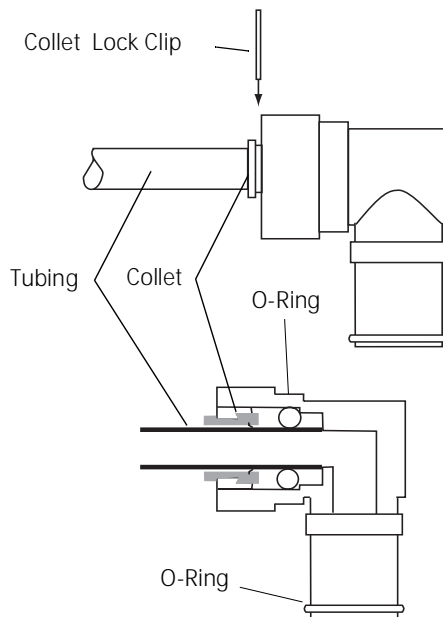

**NOTE:** Make sure the tubing is pushed past the O-rings for a secure fit. Also, when replacing any tubing, cut tubing back ~1/4 inch prior to re-inserting to prevent leaks.

Figure 5 Side View and Cutaway of Tubing Fitting



**NOTE:** For optimal system performance, we recommend using tubing lengths that are as short as possible.

### Postfilter

Install the postfilter inline with the blue permeate tubing. Make sure flow direction aligns with water path. Secure tubing with collet lock clips.

If the supplied postfilter is not used, install an ASO Cartridge inline with the blue permeate tubing. The ASO Cartridge will help maintain proper mechanical performance in the absence of the supplied postfilter. Contact your system supplier for ASO Cartridge availability.

### Drain Adapter (Optional)

The drain adapter has a rubber inlet that accepts the 3/8-inch black drain tube or the 1/2-inch red tube. The 3/8-inch black tubing will connect here if the faucet is not using the air gap module.

When the tubing is in position, use the supplied hose clamps to secure the connection.



**NOTE:** When sliding tubing into the drain adapter inlet, wet the tubing. Water will help the tubing slide into the rubber inlet.

### Feed Pressure Gauge

The supplied pressure gauge can be connected to the feed line to monitor system feed pressure. For proper system performance, the dynamic feed pressure must be between 40 psi (2.76 bar) and 80 psi (5.52 bar) when the Merlin is in operation.



**CAUTION:** The feed pressure gauge is intended for use only during installation and troubleshooting of the RO system. The pressure gauge should be removed during normal system operation because some regulatory agencies did not evaluate the RO system with the feed pressure gauge in place.

### Flush Tank (Optional)

This kit will flush product water over the membranes following each use. The flush kit extends membrane element life and reduces migration, or "creep" of ions to the product water side of the membrane elements during periods of nonuse. The "creep" of ions across the membranes often causes lower rejection at system start-up than the true capabilities of the RO system. Systems with flush kits installed will maintain higher rejection levels following periods of inactivity.

To install the optional flush kit, remove the 1/4-inch plug and insert the 1/4-inch tubing into the top fitting on the RO assembly manifold. Be sure the tubing is connected to the flush tank with an appropriate tank fitting. The empty tank air precharge should be adjusted between 8 to 10 psi.



**CAUTION:** If the flush tank is not used, the 1/4-inch fitting on the manifold must be plugged or water will leak out.

### STEP 5: INSTALL RO ASSEMBLY

The RO Assembly includes the following components: sumps (3), support leg, prefilter, RO membrane elements (2), and postfilter. The tubing is attached to the manifold by the elbow connectors. When choosing a location for the system, allow enough tubing for it to be moved for periodic servicing of the filters and membrane elements.

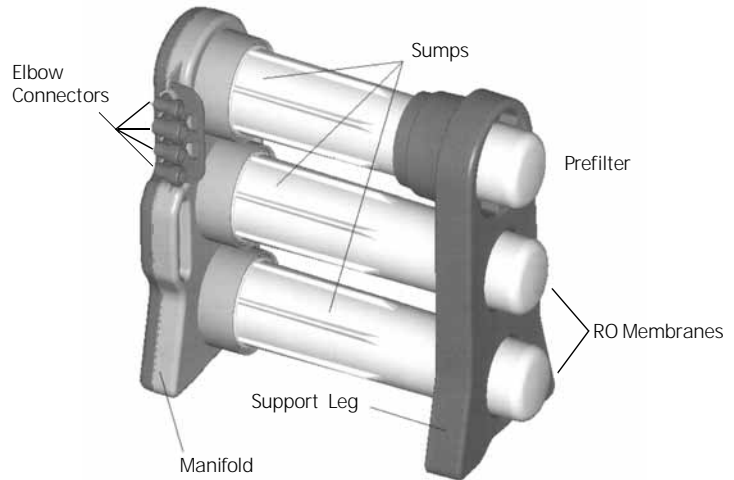
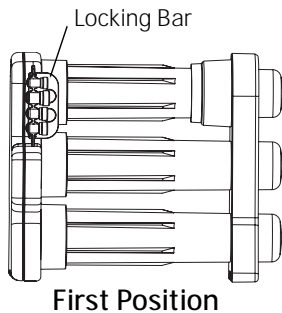

Figure 6 Merlin RO Assembly



**WARNING:** Do not attempt to mount/hang the Merlin. Do not try to drill mounting holes anywhere on the system. If putting above ground/cabinet level, a sturdy, permanent shelf is recommended.

### Recommended Placement Positions



The Merlin assembly should be positioned in one of two ways.

The first position is with the unit standing upright using the support leg with the sumps horizontal. The tubing is directed to provide the best fit.

The second position, sets the unit on end so the manifold is horizontal and the sumps are pointing up. The tubing is directed upward and the locking bar is down to lock the tubing connections.

See illustrations at left.

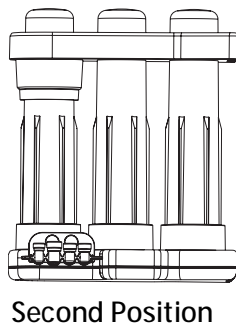

The table below shows the coding system for the fitting connections. Each fitting has a unique “keyed” socket on the manifold. Each fitting also has a graphic symbol molded into the elbow with a corresponding symbol on the manifold.

Connector Symbol	Connection	Tubing Color
O	Flushing (optional)	Blue
←	Feed-Inlet	Natural
△	Concentrate	Black
□	Product	Blue



**WARNING:** Be sure to lubricate the O-rings on the fitting elbows with silicone lubricant, prior to inserting into manifold.



**WARNING:** Do not turn the incoming water valve on until the locking bar is in place.



**NOTE:** If the installation is not using the optional flush tank, the top connection will not have tubing. Instead a plug will be inserted into the fitting. Do not remove plug unless you are attaching the tubing and the flush tank.

When all of the connections have been made, use the locking bar to hold the fittings in position. Match the symbols on the locking bar to the corresponding symbols on the manifold.

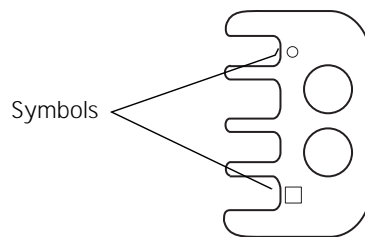

Figure 7 Locking Bar



## STEP 6: SYSTEM STARTUP

1. Inspect all connections.
2. If the flush tank is not installed, the 1/4-inch port on the manifold must be plugged.
3. Position manifold horizontal with openings facing up.
4. Remove new membrane elements from plastic packaging. The black and yellow tapes surrounding the membrane are an important part of the membrane element and should not be removed.



**CAUTION:** Elements contain a foodgrade preservative. The use of sterile/latex gloves is recommended.

5. Lubricate element O-rings, brine seals, and sump O-rings with silicone lubricant.
6. Securely insert O-ring end of membrane elements into manifold.
7. Remove prefilter from packaging. Check that gaskets are in place.
8. Place prefilter in manifold.
9. Replace sumps and tighten until it bottoms out.

### Pressure Test System

To check for leaks, the system must be filled with water and brought up to operating pressure.

1. Open cold water feed valve slowly. Run at 1/2 open for a minute, then open fully.
2. Open faucet until water runs.
3. Check for leaks.



**NOTE:** When the faucet is initially turned on, water may temporarily sputter from the air gap until the air is purged. Allow 1 to 3 hours for any trapped air noise in the system to subside.

4. Purge the system. Open the faucet and run the water through the RO system for one hour.



**NOTE:** The one hour flush removes a food grade preservative from the membrane elements. It is not harmful but may affect the taste of the water.

The RO system is now ready for use.

## TO CARE FOR THE RO SYSTEM

The components of the RO system are designed to function with minimal maintenance. However, the membrane elements and filters will need to be replaced on a regular schedule.

Run the system for at least two minutes each day for optimal performance.

### REPLACEMENT OF PREFILTER AND POSTFILTER

The carbon/sediment prefilter reduces sediment and certain chemicals, such as chlorine, from the water. Depending on water use and the amount of impurities, this filter should be replaced every six to twelve months for residential applications.

Whenever the prefilter is replaced, the postfilter should also be replaced.

Installations using more than 20 gallons product water per day should install external filters (not supplied) to reduce chlorine and sediment larger than 10 microns.

### REPLACEMENT OF RO MEMBRANE ELEMENTS

The functional life of the RO membrane elements will vary based on feed water quality. Product water should be tested periodically to verify the membrane elements are performing properly. For most residential applications, the RO membrane elements should be replaced every two to four years.



**NOTE:** Softened water is recommended for optimal system performance and RO membrane element life.

## REPLACEMENT OF THE PREFILTER, POSTFILTER, AND RO MEMBRANE ELEMENTS

1. Turn off the water supply to the RO System.
2. Reduce system water pressure by opening the faucet.



**CAUTION:** Even with the water supply turned off the membrane and prefilter sumps will contain a considerable amount of water. By positioning the RO assembly in a sink or tub, most of the water will be contained.

3. Disconnect locking bar and place the fittings (with tubing still connected) into a tub or bucket.
4. Move system into a contained area, such as a sink or tub.

5. Remove the support leg from the three sumps and unscrew the top sump as shown to access the prefilter element. The support leg functions as a wrench to loosen the sump, Figure 7.

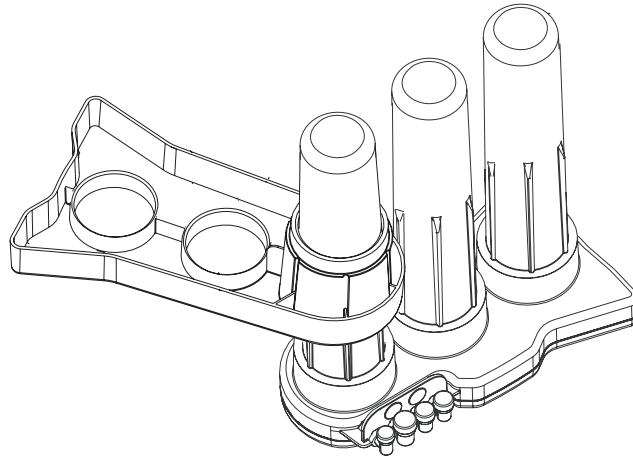

Figure 8



**NOTE:** There is no need to disconnect tubing from fittings on the manifold. Remove locking bar and pull fittings out. Lubricate O-rings with silicone prior to re-assembly.



**NOTE:** If changing only the prefilter and postfilter, the other sumps do not need to be removed.

If changing the membrane elements, the prefilter and postfilter should also be changed.

6. Remove exhausted prefilter and discard.



**CAUTION:** The person handling the filters and membrane elements must have clean hands to keep the system sanitized. The use of sterile/latex gloves is recommended.

7. If changing membrane elements:
  - A. Remove membrane sumps. Remove and discard used elements.
  - B. Remove new elements from packaging.



**CAUTION:** Elements contain a foodgrade preservative. The use of sterile/latex gloves is highly recommended.

- C. Lubricate element O-rings, brine seals, and sump O-rings with

silicone lubricant.

- D. Securely insert O-ring end of elements into manifold. See Figure 8.
- E. Replace sumps and tighten until it bottoms out.



**NOTE:** The system should be sanitized whenever a membrane element or filter is replaced.

- 8. Sanitize the system.
  - A. The manifold should be positioned flat with the sump connections facing up.

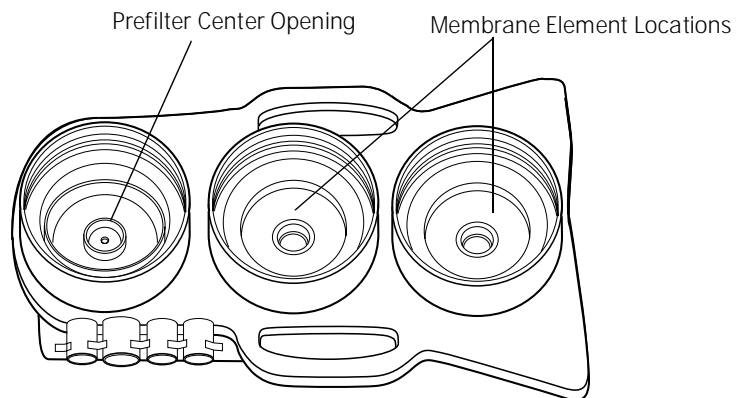

Figure 9

- B. Pour a tablespoon (15 milliliters) of chlorine bleach into the center opening of the prefilter sump connection. See Figure 9.
- 9. Install prefilter.
  - A. Remove new prefilter from packaging. Ensure gaskets are secure. Insert prefilter into proper opening on manifold.
  - B. Lubricate sump O-ring with silicone lubricant.
  - C. With the prefilter element in place, screw the sump into the connection. Tighten until it bottoms out.
- 10. Replace the postfilter.
  - A. To unlock the fittings from the tubing, push down on the collet sleeves and pull the tubing out.
  - B. Discard the exhausted postfilter.
  - C. To prevent leaks, cut the tubing back approximately 1/4 inch prior to connecting the new postfilter. Make sure flow direction arrow aligns with water path. Reinsert tubing and collect locks.
- 11. Re-connect the fittings to the manifold and lock in position with locking bar.

12. Re-position the assembly and turn the water supply on. Check the system for any leaks.



**CAUTION:** When the faucet is opened, water may sputter from the air gap until the trapped air is purged.

13. Open the faucet and run water for two minutes.



**NOTE:** Carbon fines may be present until the postfilter element is flushed out.

14. Shut off the faucet and allow the system to stand idle for 20 to 30 minutes.

15. Open the faucet and run water for five minutes.

16. Check for any system leaks.



**NOTE:** If the two RO membrane elements were replaced the system should be flushed for one hour. This flush removes the food grade preservative from the elements. The preservative is not harmful but may affect the taste of the water.

The RO system is now ready for use.

# APPENDIX

## MERLIN - COMPLETE SYSTEMS

\*See *Merlin Components* for configuration details.

Part Number	Description
1239705	Sump - interchangeable for all 3 positions
1244617	Manifold - complete
1239708	Support Leg
1240564	Drain Boa Kit
1240620	3/8-inch Black Tubing - 500 foot roll - John Guest Brand
1240621	3/8-inch Blue Tubing - 500 foot roll - John Guest Brand
1240622	1/2-inch Natural (clear) - 250 foot roll - John Guest Brand
1240623	1/2-inch Red Tubing - 250 foot roll - John Guest Brand
1240117	1/2-inch Feed Disconnect Elbow - White
1240118	3/8-inch Permeate Disconnect Elbow - Blue
1264462	3/8-inch Drain Disconnect Elbow - Black
1240119	1/4-inch Flush Disconnect Elbow - Light Blue
1239731	Locking Bar
1240326	Sump O-Ring
1254894	Airgap Faucet Kit
1255693	Complete Fittings and Locking Bar Kit
1255736	Complete Tubing Install Kit

## REPLACEABLE CARTRIDGES

Part Number	Description
1238342	Membrane Element - 1/box
1237460	Carbon Prefilter - 12/box
1244746	Carbon Postfilter - 25/box
1266690	10-micron Sediment Prefilter - 15/box . Box quantities only.
1269491	ASO Cartridge

## ACCESSORIES

Part Number	Description
1240632	Inlet Booster Pump, 110V/60Hz, Intermittent Duty
1269342	Inlet Booster Pump, 230 V/ 50 Hz, Intermittent Duty
1013501	Silicone Lubricant Pack
1240629	Feed Valve Tee - 1/2" x 1/2" x 1/2" OD Tubing - G.A. Murdock USA
1240630	Feed Valve Tee - 5/8" x 5/8" x 1/2" OD Tubing - G.A. Murdock USA
1262403	Feed Valve Tee - 5/8" x 5/8" x 1/2" OD Tubing -SeaTech
1262404	Feed Valve Tee - 14 mm x 14 mm x 1/2" OD Tubing -SeaTech
1262406	Feed Valve Tee - 15 mm x 15 mm x 1/2" OD Tubing -SeaTech
1262408	Feed Valve Tee - 1/2" x 1/2" threaded x 1/2" Tubing -SeaTech
1269967	Replacement Air Gap - 10/box
3002494	Feed Pressure Gauge (1/2-inch quick connect fitting)
3002791	TDS and Temperature Meter
3002840	Hardness Test Strip - 10/box
1242806	Nitrate/Nitrite Test Strip

## NON-STOCKED INDIVIDUAL COMPONENTS

Part Number	Description	Recommended Source
1240626	Individual Collet Lock - 1/4-inch Red - John Guest PN PIC1808R-X	John Guest USA
1240627	Individual Collet Lock - 3/8-inch White - John Guest PN PIC1812W-X	John Guest USA
1240628	Individual Collet Lock - 1/2-inch Blue - John Guest PN PIC1816B-X	John Guest USA
1240624	1/4-inch JG Plug - John Guest PN P10808S	John Guest USA
1240625	Faucet Connection Fitting - John Guest PN CI3212U7S	John Guest USA
1268260	Merlin Flush Kit (8L RO Storage Tank, 1/4-inch Tubing, Tank Fitting)	RO Tank Supplier



## DIMENSIONS

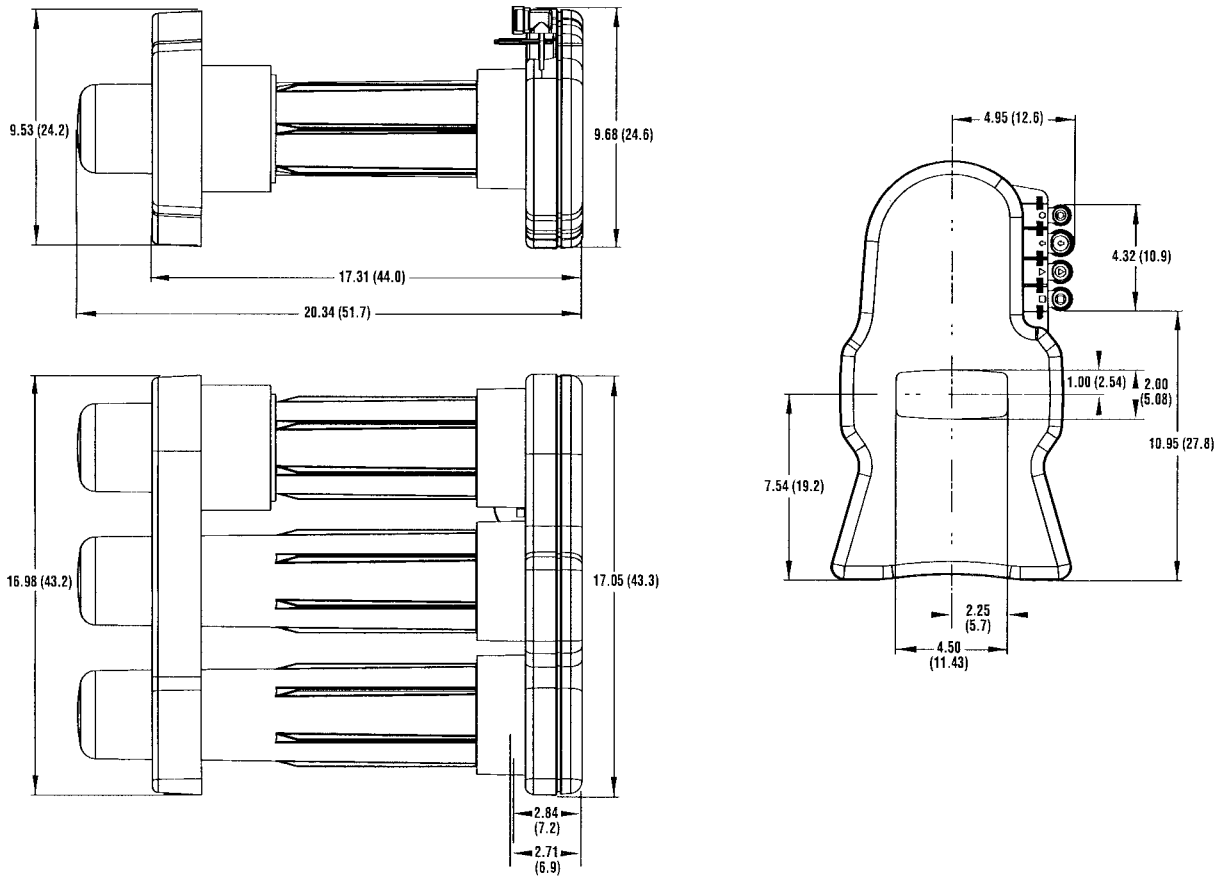

### Performance Specifications<sup>1, 2</sup>

Average Permeate Flow Rate	0.50 gals/min (1.89 Lpm)
Average TDS Rejection (NaCl) <sup>3</sup>	90%

### Minimum and Maximum Operating Conditions

Condition	Minimum	Maximum
Inlet Pressure	40 psi (2.76 bar)	80 psi (5.52 bar)
Inlet Temperature	40°F (4.44°C)	100°F (37.78°C)
Inlet TDS	50 mg/L	2,000 mg/L
Inlet Hardness	0 mg/L (0 grain)	171 mg/L (10 grain)
Inlet Chlorine	0 mg/L	1.0 mg/L
Inlet Iron	0 mg/L	0.1 mg/L
Inlet Manganese	0 mg/L	0.05 mg/L
Inlet pH	4	10
Inlet Turbidity	0	1 NTU

1. Based on 50 psi (3.44 bar), 77°F (25°C), 750 mg/L NaCl, 23.7% Recovery

2. System is designed for use on potable water systems only.

3. Specifications based on GE Water & Process Technology testing data. For complete WQA test results to ANSI/NSF 58 standard, see the Merlin Performance Data Sheet P/N 1263717.

## TROUBLESHOOTING

Issue	Possible Cause	Corrective Action
Low product flow rate	<ul style="list-style-type: none"> <li>A. Low driving pressure.</li> <li>B. Low water temperature or high total dissolved solids (TDS).</li> <li>C. Plugged prefilter.</li> <li>D. Scaled or fouled RO membrane.</li> <li>E. Faucet not adjusted properly.</li> <li>F. Plugged postfilter.</li> <li>G. Leak or kink in product line.</li> </ul>	<ul style="list-style-type: none"> <li>A. Increase feed pressure. Consider pump for low pressure locations. Use short tubing runs to decrease flow restriction. Increase tubing diameter for longer distances.</li> <li>B. Increase feed water temperature or feed pressure to compensate.</li> <li>C. Replace plugged prefilter. Consider sediment prefilter for non-chlorinated applications.</li> <li>D. Replace membranes.</li> <li>E. Adjust faucet t-bar setting as tight as possible without causing leaks from the faucet.</li> <li>F. If flow into the postfilter is acceptable, replace postfilter.</li> <li>G. Find and repair leak or kink.</li> </ul>
Concentrate water runs to drain after faucet shut off	<ul style="list-style-type: none"> <li>A. Plugged prefilter.</li> <li>B. System air lock.</li> <li>C. Leak in product line.</li> </ul>	<ul style="list-style-type: none"> <li>A. Replace plugged prefilter. Consider sediment prefilter for non-chlorinated applications.</li> <li>B. Install Merlin postfilter or ASO cartridge in product line to relieve air lock.</li> <li>C. Find and repair leak. Install pressure gauge in product line to help identify a product pressure leak.</li> </ul>
Poor product water quality	<ul style="list-style-type: none"> <li>A. Water sample taken during system flush.</li> <li>B. Low driving pressure.</li> <li>C. Plugged prefilter.</li> <li>D. Scaled, fouled, or damaged RO membrane.</li> </ul>	<ul style="list-style-type: none"> <li>A. Take sample after three minutes of continuous operation. Install flush tank for automatic system flush.</li> <li>B. Increase feed pressure. Consider pump for low pressure locations. Use short tubing runs to decrease flow restriction. Increase tubing diameter for longer distances.</li> <li>C. Replace plugged prefilter. Consider sediment prefilter for non-chlorinated applications.</li> <li>D. Replace RO membranes.</li> </ul>

# INSTALLATION INFORMATION AND INSTRUCTIONS FOR [DRAIN-BOA™ MODEL DC9700] DRAIN COUPLING

Form# 970000 (Sheet 1)  
Drain-BOA™ (P/N DC9700)

[Please study all information included before first installation.]

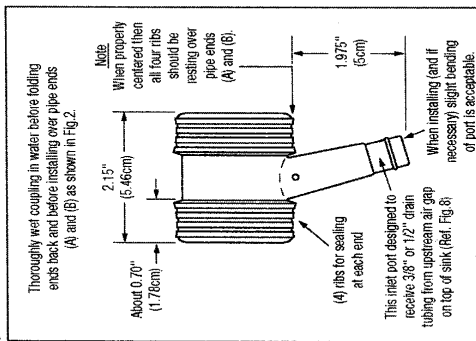

**Fig. 1**  
**Drain-BOA™ Rubber Coupling folded back on itself at each end and ready to be installed in the kitchen sink tailpiece**  
[Measures just over 2.125\"/>

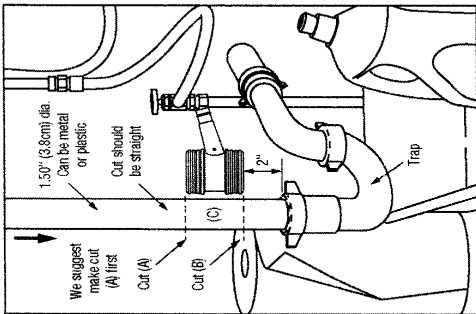

**Fig. 2**  
**Typical view under kitchen sink with 1.5\"/>**

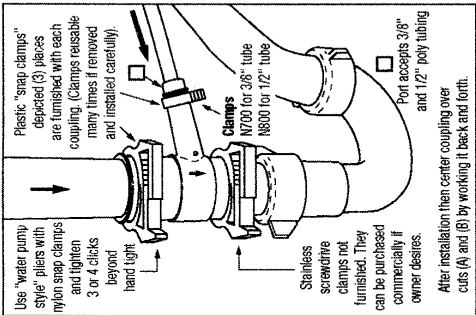

**Fig. 3**  
**Typical view of (Fig. 2) plastic tailpiece after installing the Drain-BOA™ Rubber Coupling**  
[Polyethylene drain tubing from air gap properly inserted to inner stop and clamped.]  
[Note: Wet tubing only with water before installation.]

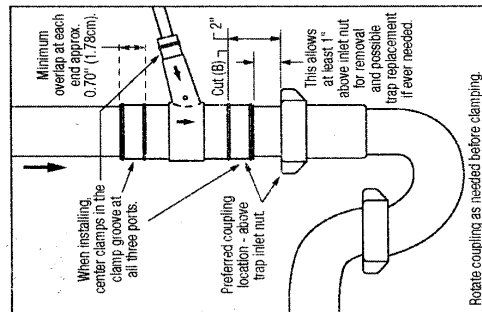

**Fig. 5**  
**This coupling depicted before the clamps are installed.**  
[If large stainless screw drive clamps are used (ref. Fig. 6), their width must be 0.50\"/>

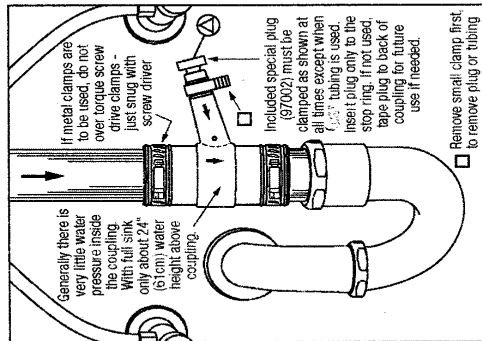

**Fig. 6**  
**Depicts Drain-BOA™ coupling installed with stainless steel screw drive clamps on the large ports.**  
[Either tubing or solid plug (97002) must be installed at all times, otherwise leakage will occur out this port.]

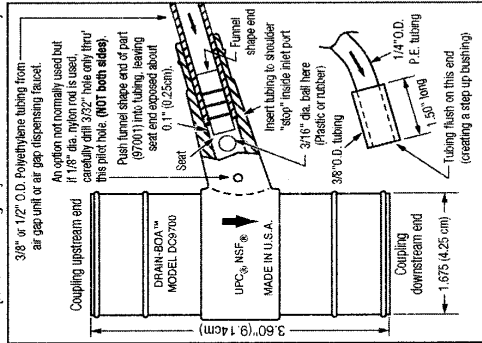

**Fig. 7**  
**[Depicts certain dimensions and marking Cut 3/8\"/>**

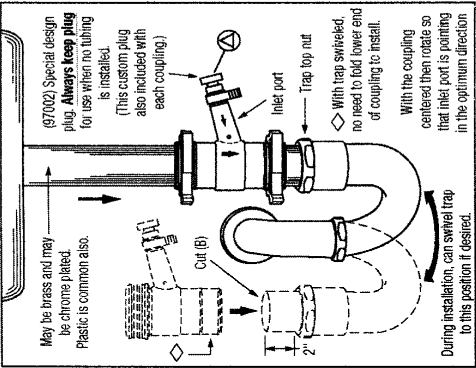

**Fig. 4**  
**Depicts metal 1.5\"/>**

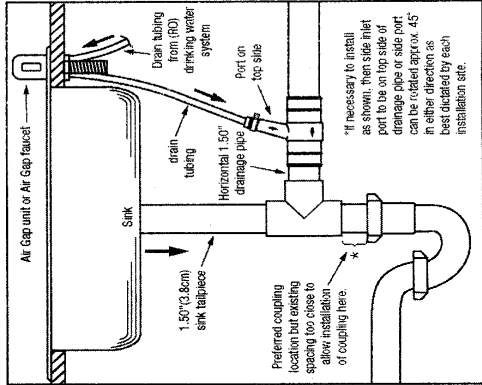

**Fig. 8**  
**Depicts Drain-BOA™ coupling installed in a horizontal branch below kitchen sink, due to space limitations at the preferred installation site.**  
[Always install unit according to flow arrows.]

System manufactured by:

GE  
Water & Process Technologies  
5730 N. Glen Park Road  
Milwaukee, WI 53209-4454  
U.S.A.

Direct spare parts and service inquiries to the system's installing dealer.

Contact your installing dealer for spare parts or service:

