

ASSEMBLY INSTRUCTIONS

MODEL # 50-LD0101

SUPPLIER CODE: LDCZ

Essential Computer Desk, White

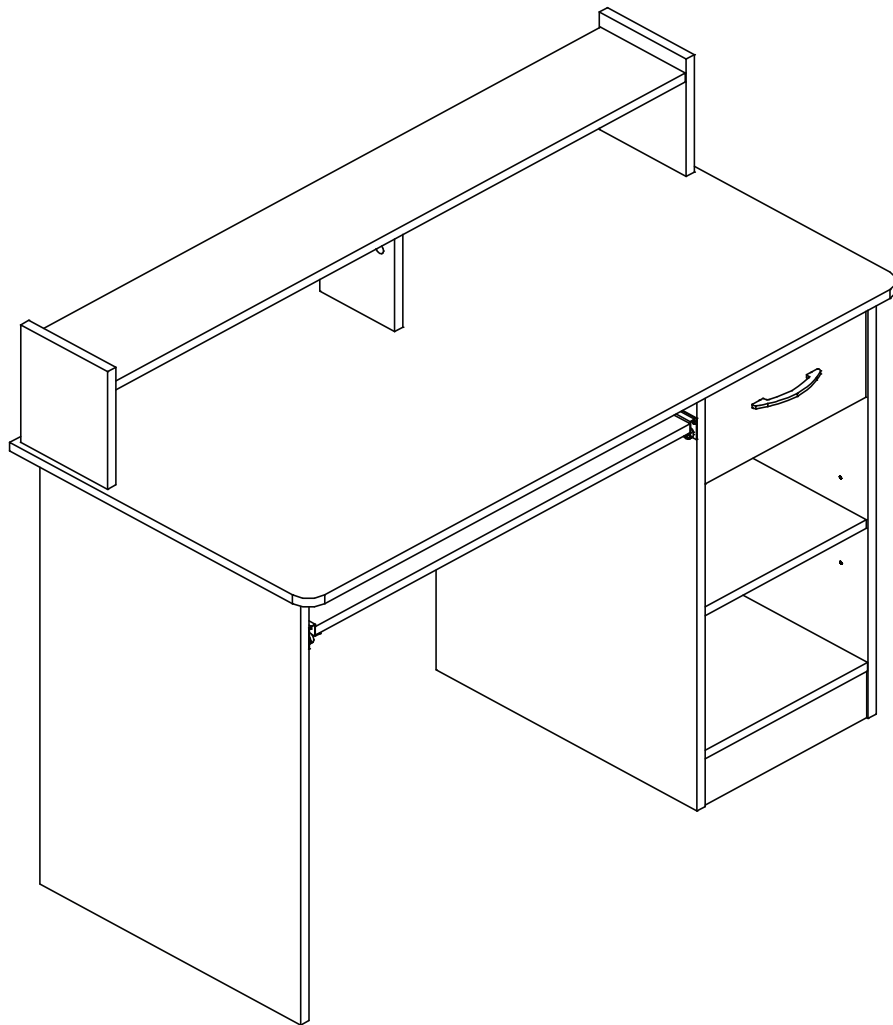

CUSTOMER SERVICE

For fastest service on claims, requests for replacement parts,
or questions, please visit our website at:

www.comfortproducts.net/support
e-mail: customerservice@comfortproducts.net





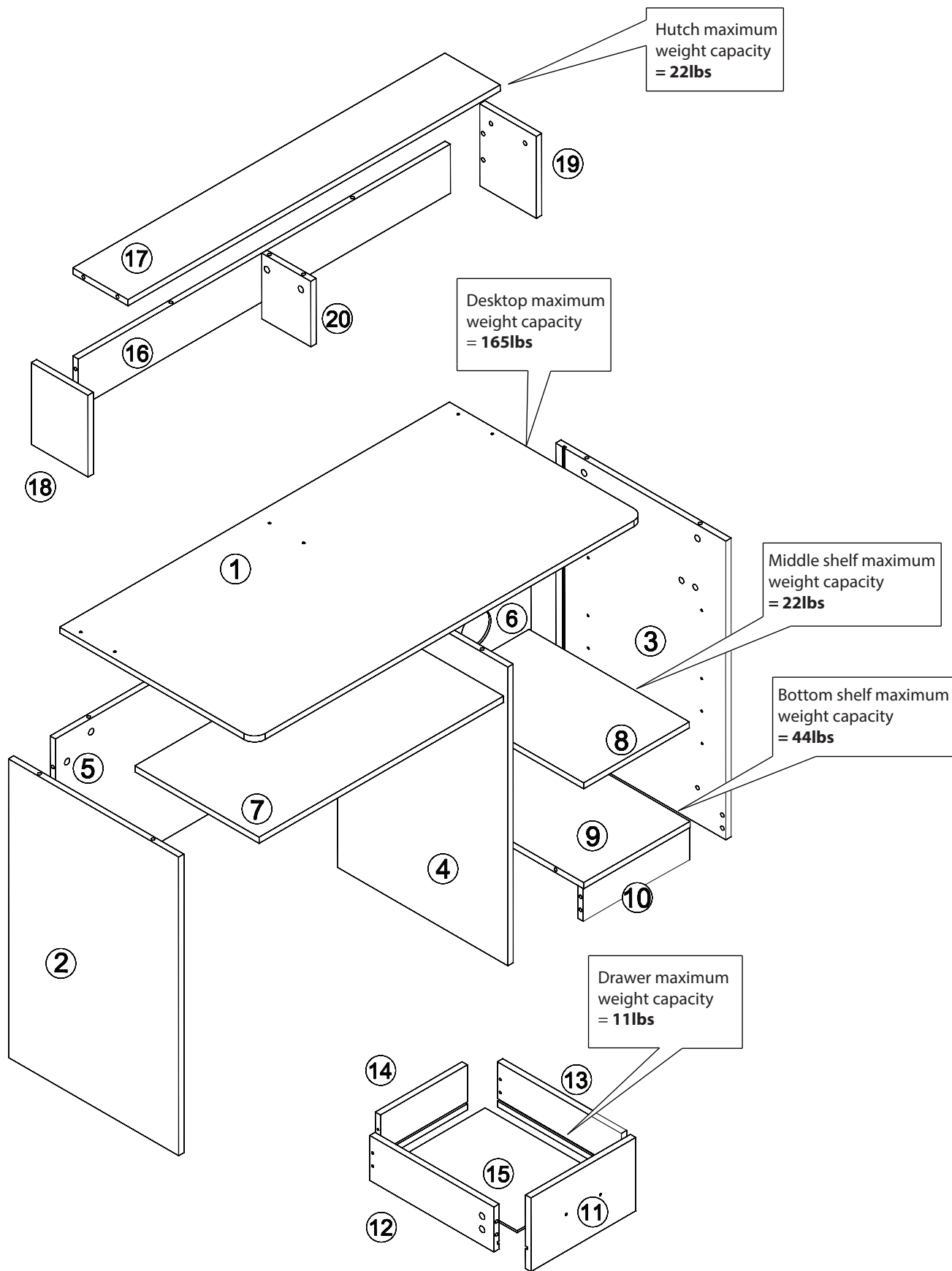

Keep your sales receipt as documentation of your ownership.

ASSEMBLY OVERVIEW

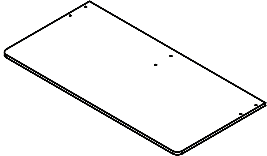
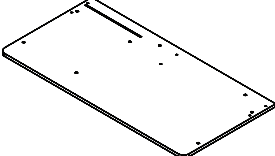

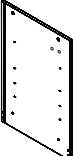

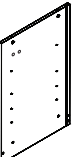
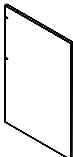
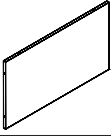
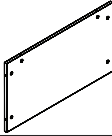
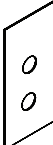
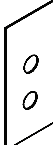

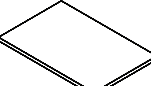
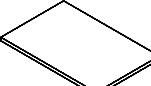
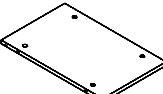
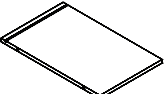
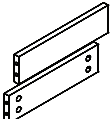
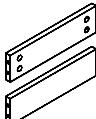
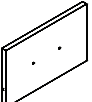
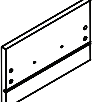









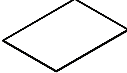
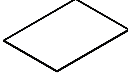
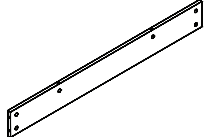
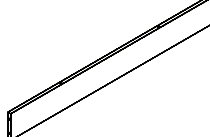
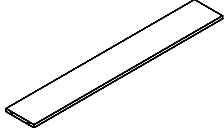
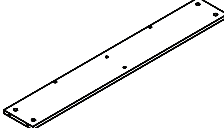

PARTS LIST 1 OF 2

ITEMS ARE NOT SHOWN TO SCALE.

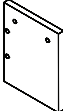
#	DESCRIPTION	SIDE 1	SIDE 2	STOCK #	QTY.
1	Desktop			51-LD0101DT	1
2	Left Board			51-LD0101LB	1
3	Right Board			51-LD0101RB	1
4	Middle Board			51-LD0101MB	1
5	Left Back Board			51-LD0101LBB	1
<u>6</u>	Right Back Board			51-LD0101RBB	1
7	Keyboard Tray			51-LD0101KT	1
8	Middle Shelf			51-LD0101MS	1
<u>9</u>	Bottom Shelf			51-LD0101BS	1
10	Support Board			51-LD0101SPB	3
11	Drawer Front			51-LD0101DF	1

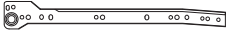
PARTS LIST 2 OF 2

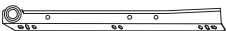

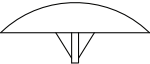



ITEMS ARE NOT SHOWN TO SCALE.

#	DESCRIPTION	SIDE 1	SIDE 2	STOCK #	QTY.
12	Left Drawer Board			51-LD0101LDB	1
13	Right Drawer Board			51-LD0101RDB	1
14	Drawer Back			51-LD0101DB	1
15	Drawer Bottom			51-LD0101DBM	1
16	Hutch Back			51-LD0101HB	1
17	Hutch Top			51-LD0101HT	1
18	Hutch Left			51-LD0101HL	1
19	Hutch Right			51-LD0101HR	1
20	Hutch Middle			51-LD0101HM	1
21a	Outer Drawer Rollers	Left 	Right 	51-LD0101DS	2 sets of 4
21b	Inner Drawer Rollers	Left 	Right 		
22	Plastic Cap			51-LD0101CA	14

HARDWARE LIST

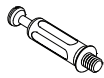
EXTRA HARDWARE INCLUDED FOR YOUR CONVENIENCE. ITEMS ARE NOT SHOWN TO SCALE.

HARDWARE KIT
STOCK # 51-LD0101HA

PART	DESCRIPTION		QTY.
A	M4 X 40MM		10
B	M4 X 18MM		2
C	M4 X 14MM		16
D	Minifix Bolt		44
E	Cam		44
F	Drawer Handle		1
G	Foot Pin		6
H	Shelf Support		4
	Extra Hardware		1 set

⚠ CAUTION

- READ THE INSTRUCTION MANUAL BEFORE ASSEMBLING.
- REMOVE ALL PIECES BEFORE BEGINNING INSTALLATION.
- OPEN THE HARDWARE AS NEEDED .
- ASSEMBLE IN AN AREA WITH PLENTY OF SPACE.
- READ EACH STEP BEFORE BEGINNING CONSTRUCTION.
- NEVER FORCE THE SCREWS OR FITTINGS.
- KEEP THIS MANUAL FOR FUTURE REFERENCE.
- TIGHTEN ALL THE SCREWS EVERY 6 MONTHS.
- HAVE A SCREWDRIVER BEFORE YOU BEGIN ASSEMBLING (NOT INCLUDED).
- DO NOT USE A POWER DRILL.

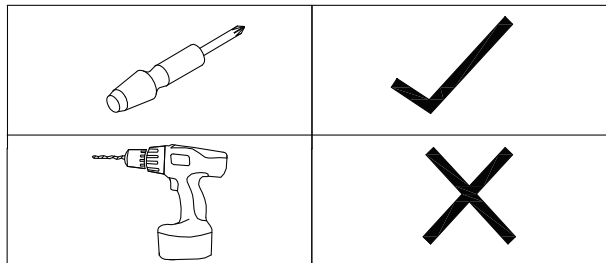

CLEANING AND CARE

- CLEAN SURFACES WITH A DRY OR DAMP CLOTH.
- DO NOT USE ABRASIVE CLEANERS.

IF YOU ARE MISSING ANY OF THESE PARTS, OR IF YOU HAVE A DAMAGED PART, PLEASE VISIT WWW.COMFORTPRODUCTS.NET/SUPPORT REFERENCE THE MODEL # ON THE FRONT OF THIS MANUAL. SIMPLY COMPLETE THE INFORMATION, INCLUDING THE PART YOU NEED. THE PART WILL NORMALLY BE SHIPPED WITHIN 48 HOURS.

ASSEMBLY INSTRUCTIONS

STEP 1

Use a hammer to attach foot pins (G) to the bottom of the left (2), middle (4), and right (3) boards.

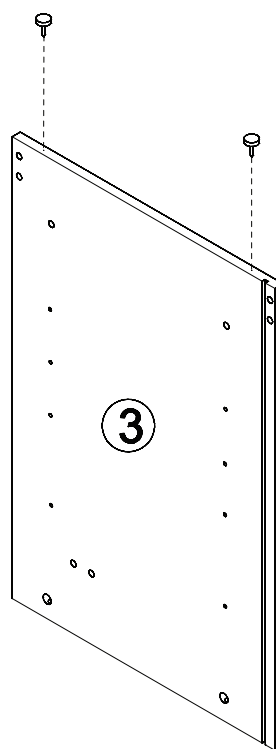
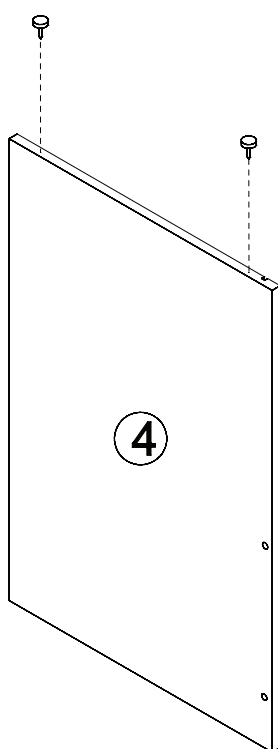
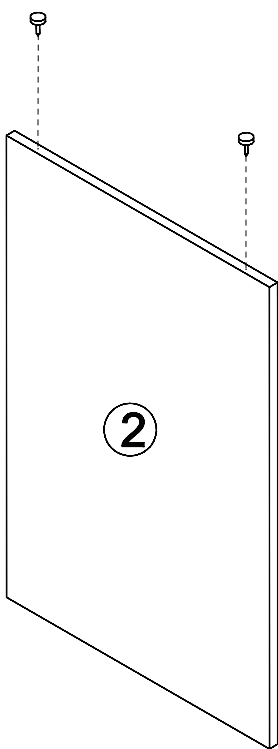

ASSEMBLY INSTRUCTIONS

STEP 2

Attach a left outer drawer roller (21a) to the left board (2) and a right outer drawer roller (21a) to the right board (3) using small screws (C). Attach two rollers to the middle board (4), a **right** outer roller (21a) to the **left** side and a **left** outer roller (21a) to the **right** side. Refer to drawing below for which holes in the roller to use.

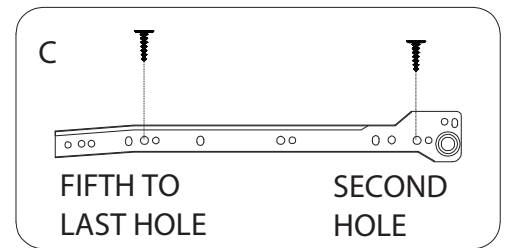
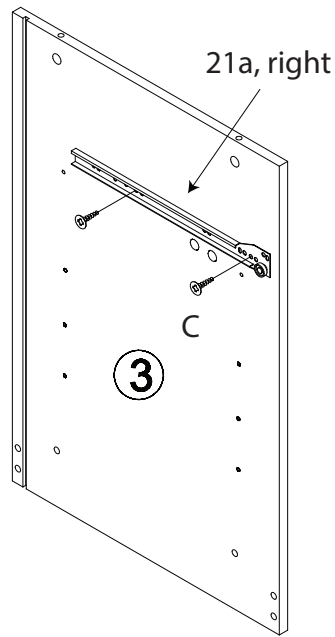
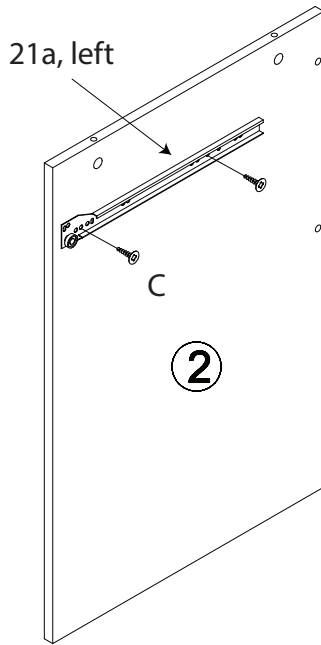

Left Side

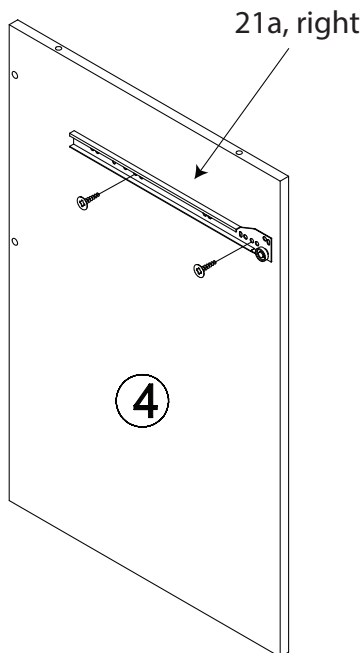

Right Side

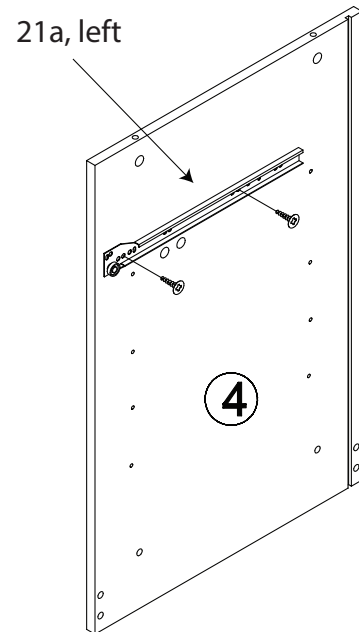

ASSEMBLY INSTRUCTIONS

STEP 3

Screw two minifix bolts (D) into the left board (2) and six bolts into the right board (3) as shown. Then screw two minifix bolts (D) into the left side of the middle board (4) and six bolts into the right side of the middle board. Do not overtighten bolts or cams will not lock properly.

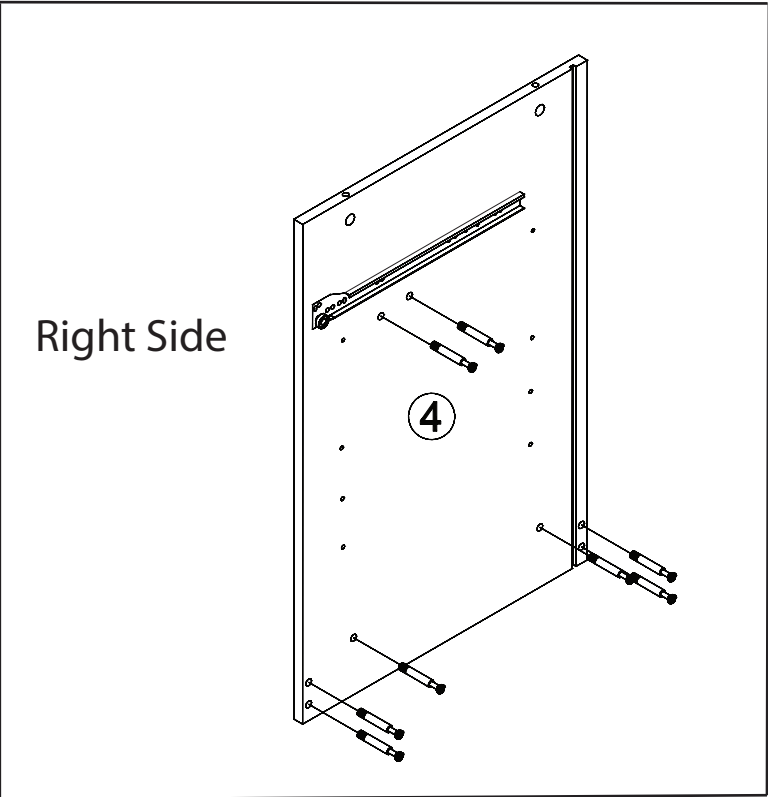
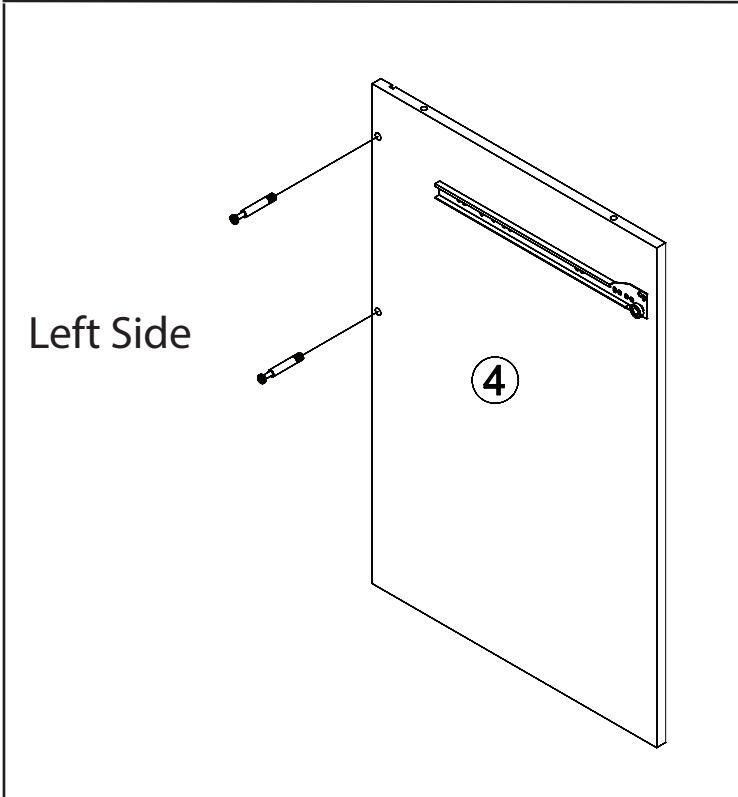
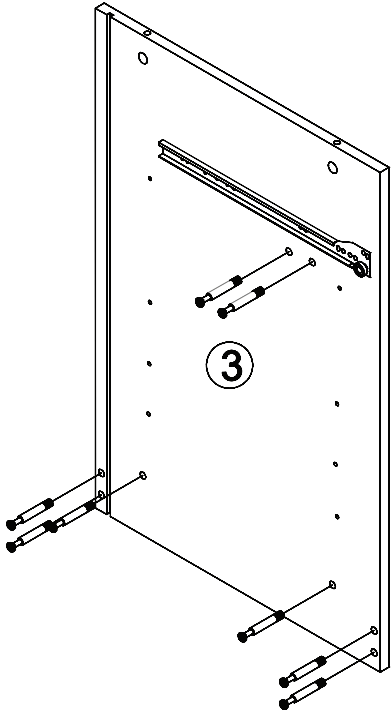
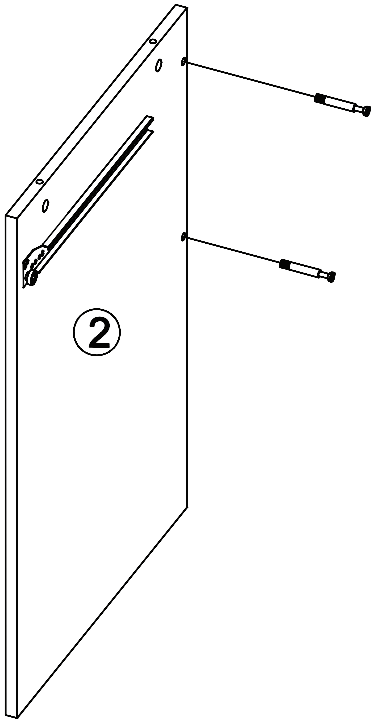

ASSEMBLY INSTRUCTIONS

STEP 4

Insert cams (E) into the bottom shelf (9) and into the two support boards (10). Make sure the arrows are facing the smaller holes which the bolts go into. First, attach shelf and support boards to the middle board (4), and then attach these to the right board (3) by aligning the bolts and cams. With a screwdriver turn the cams about 1/2 turn clockwise to lock into place. CAUTION: Do not overtighten cams.

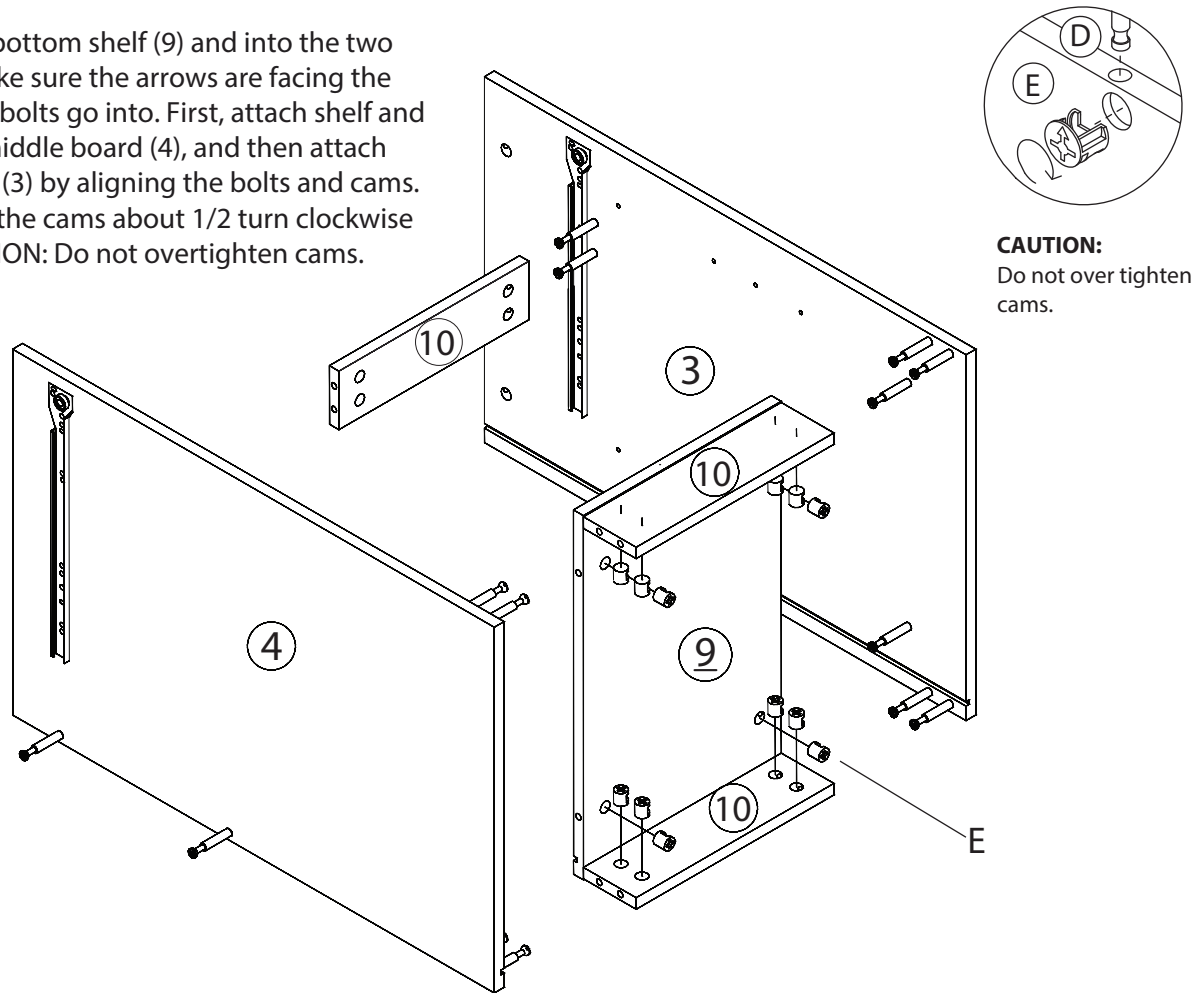

CAUTION:
Do not over tighten
cams.

STEP 5

Insert right back board (6) into grooves as shown.

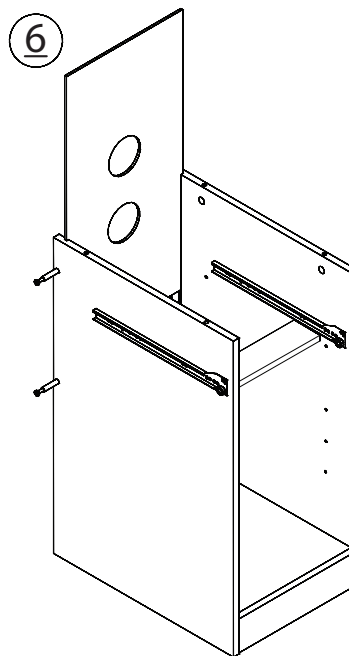

ASSEMBLY INSTRUCTIONS

STEP 6

Insert four cams (E) into the left back board (5). Make sure arrows are facing the smaller holes. Attach back board (5) to left board (2) and middle board (4). Turn the cams about 1/2 turn clockwise to lock into place. CAUTION: Do not overtighten cams.

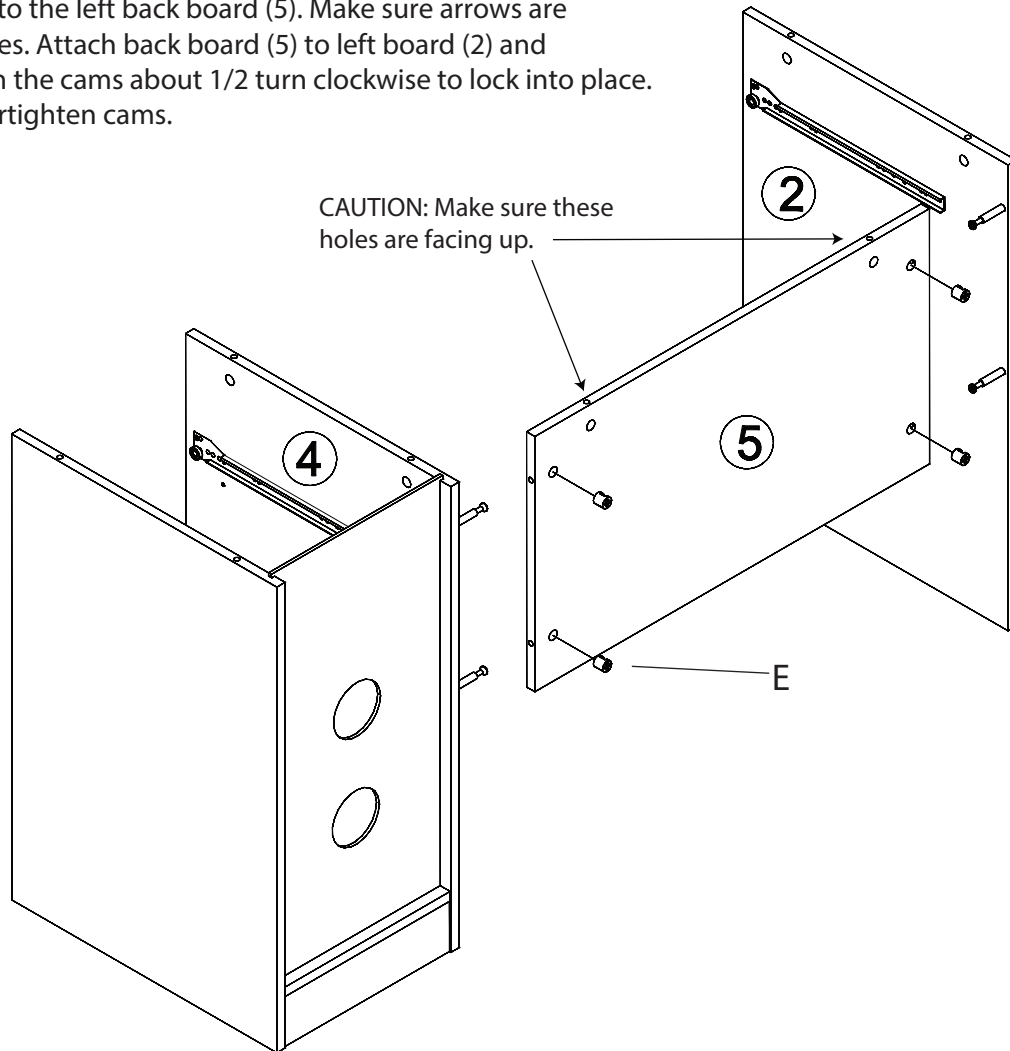

STEP 7

Screw minifix bolts (D) into hutch top (17), hutch left board (18), and hutch right board (19).

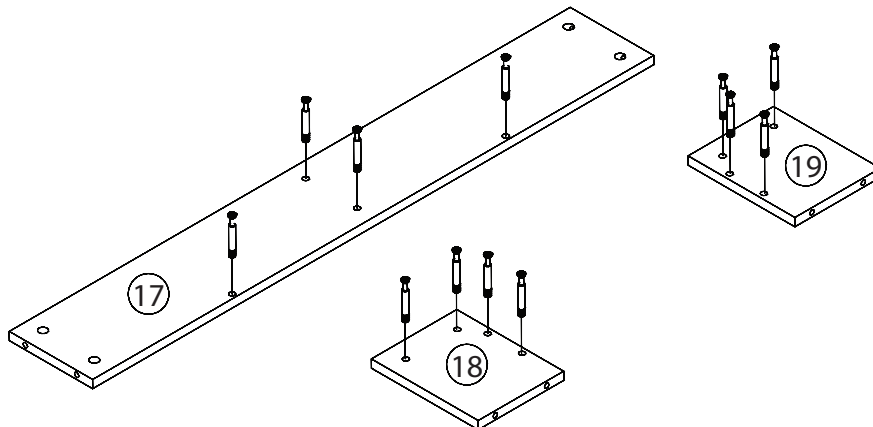

ASSEMBLY INSTRUCTIONS

STEP 8

Insert two cams into the hutch back board (16) and attach to the hutch top board (17). Insert ten cams into the hutch back (16), hutch top (17), and hutch middle board (20). Attach hutch left (18), hutch middle (20), and hutch right (19) to the back and top boards.

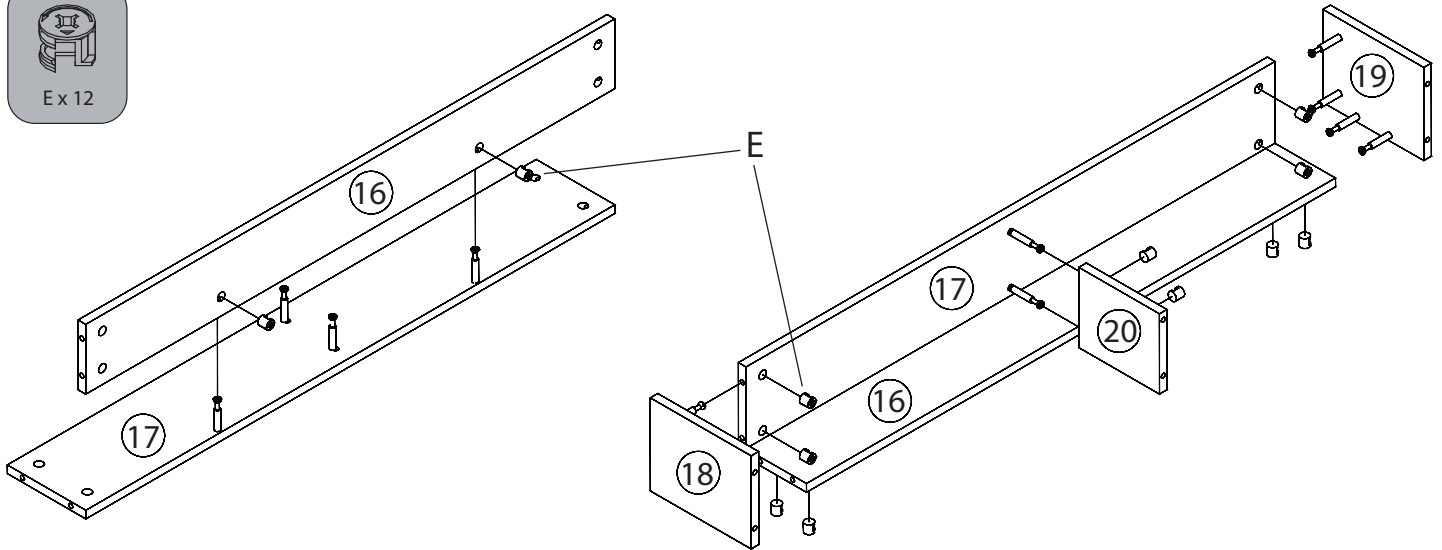

STEP 9

Screw eight minifix bolts (D) into desktop (1). Attach hutch to desktop using six screws (A) as shown.

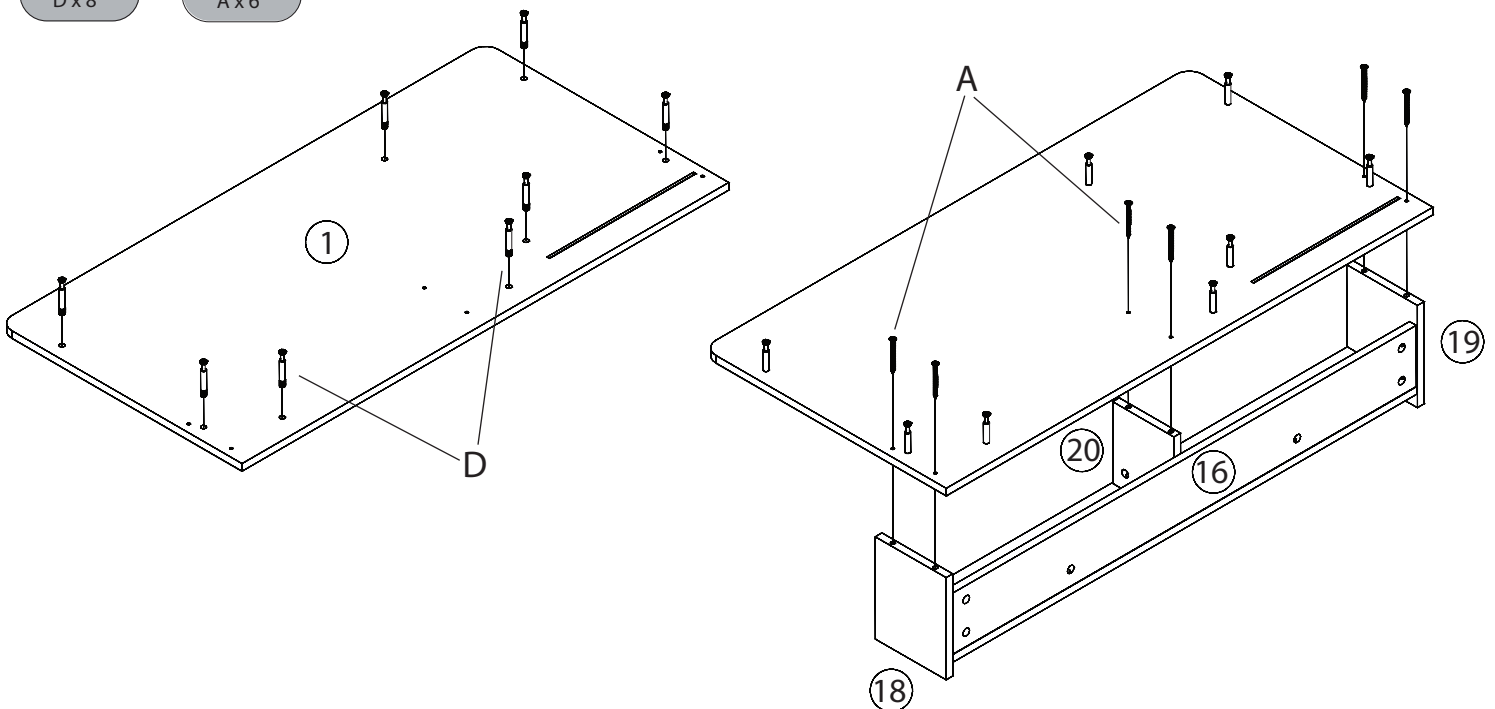

ASSEMBLY INSTRUCTIONS

STEP 10

Insert eight cams (E) into the left, middle, and right boards and left back board as shown. Attach desktop (1) with hutch to the lower part of the desk by aligning the eight bolts (D) (already screwed into the desktop) with cams. Tighten cams 1/2 turn.

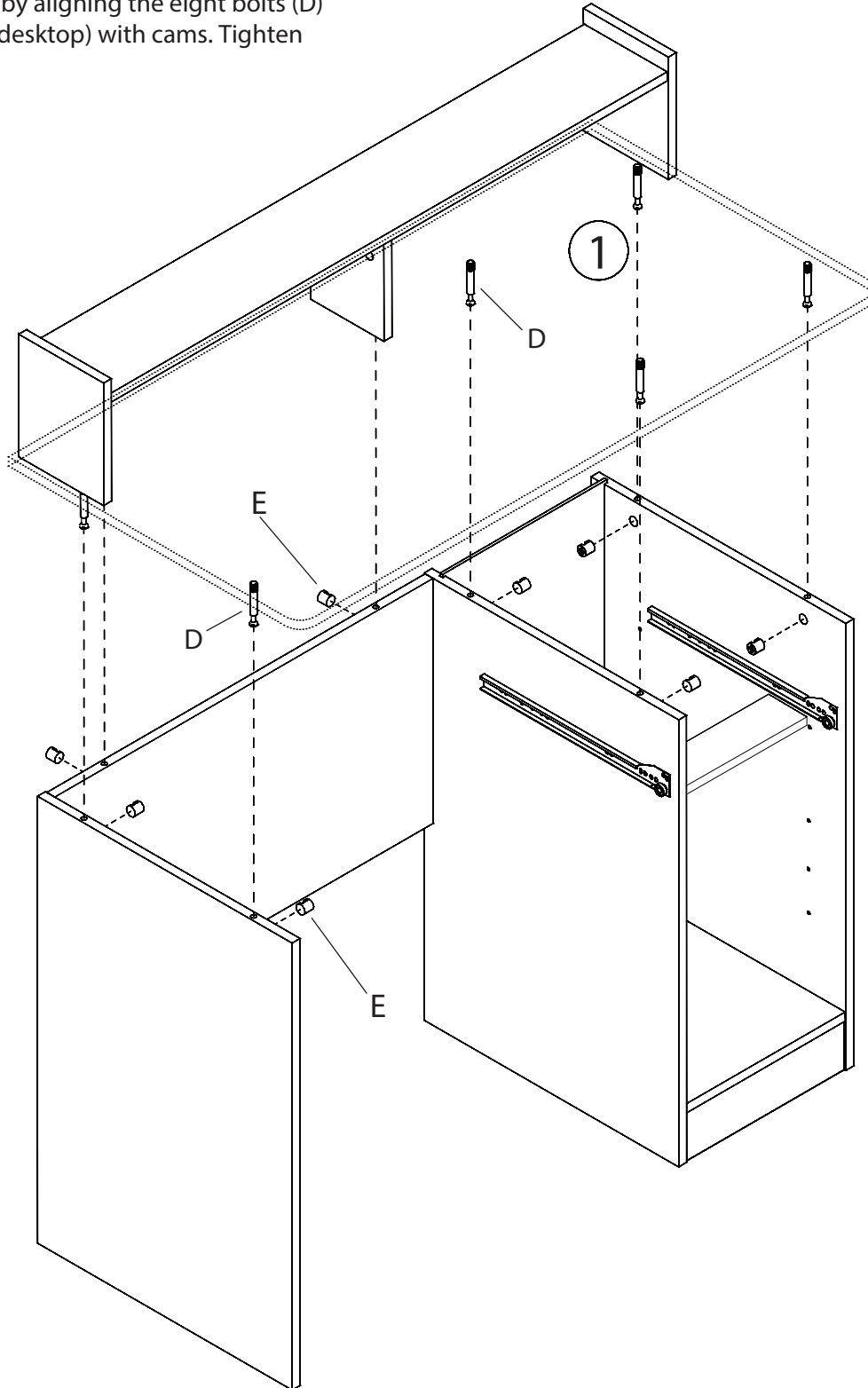

ASSEMBLY INSTRUCTIONS

STEP 11

Screw four minifix bolts (D) into the drawer front (11).

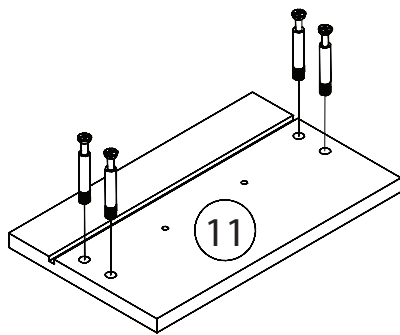

STEP 12

Insert cams into the left (12) and right (13) drawer boards and attach both boards to the drawer front (11). Make sure the grooves for the drawer bottom are aligned.

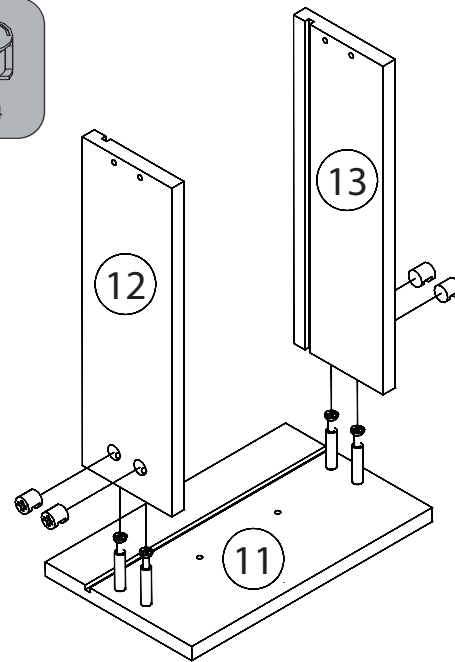

STEP 13

Insert drawer bottom (15) into grooves.

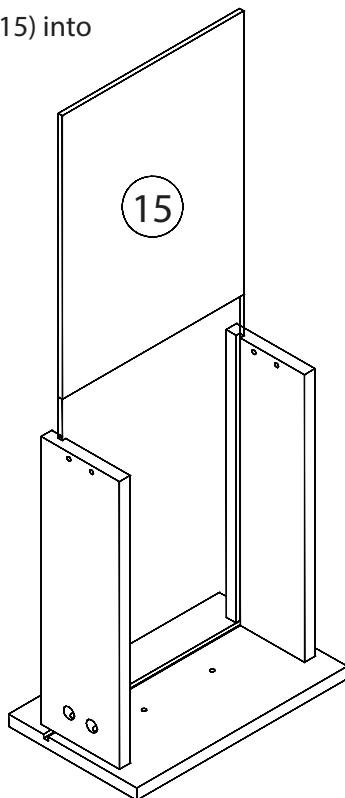

STEP 14

Align groove in drawer back (14) with drawer bottom. Attach drawer back (14) to left and right drawer boards using four screws (A).

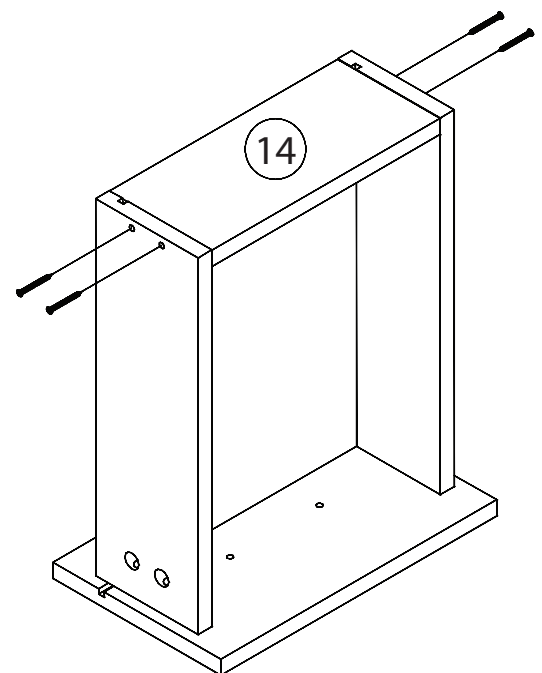

ASSEMBLY INSTRUCTIONS

STEP 15

Attach drawer handle (F) to drawer front using two screws (B).

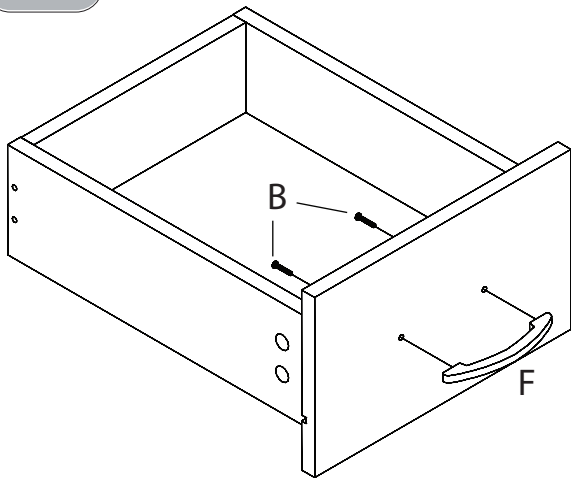

STEP 16

Attach two inner drawer rollers (21b), one left and one right, to the bottom of drawer using four screws (C) as shown. Make sure rollers are oriented to the back of the drawer. Refer to drawing below for which holes in the roller to use.

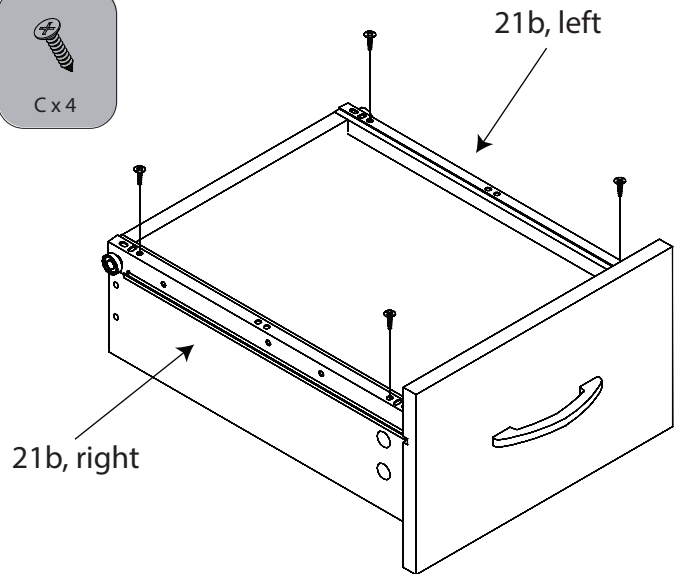

STEP 17

Attach two inner drawer rollers (21b), one left and one right, to the bottom of the keyboard tray (7) using four screws (C).

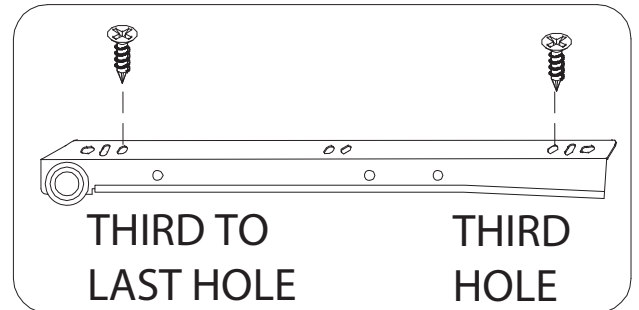
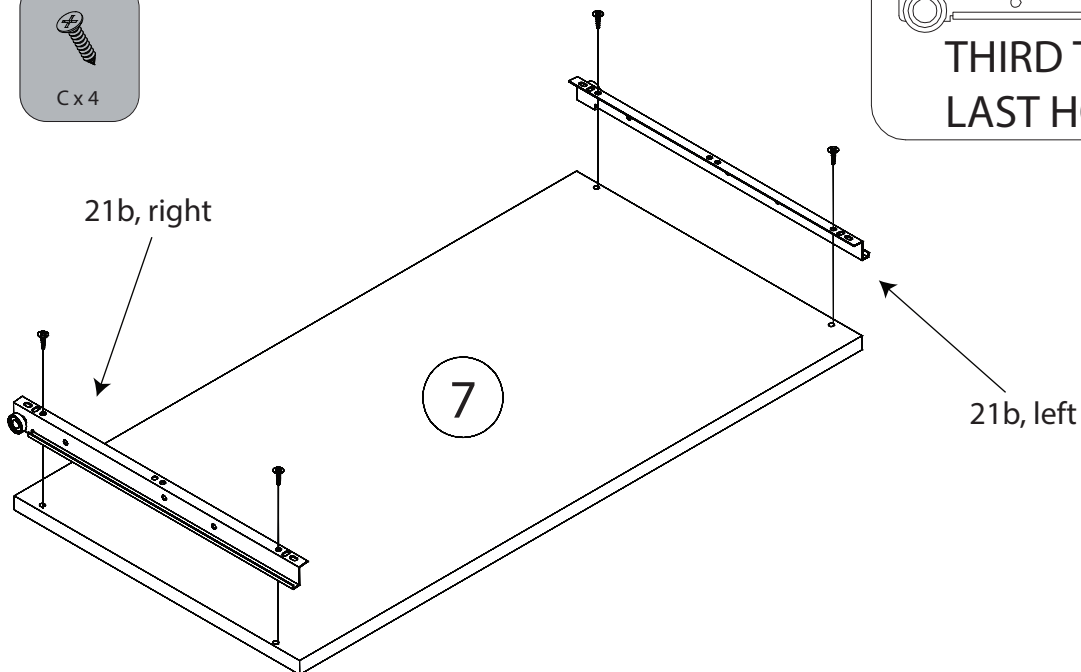

ASSEMBLY INSTRUCTIONS

STEP 18

Insert shelf supports (H) into any of the four sets of holes, according to desired height. Place middle shelf (8) on supports.

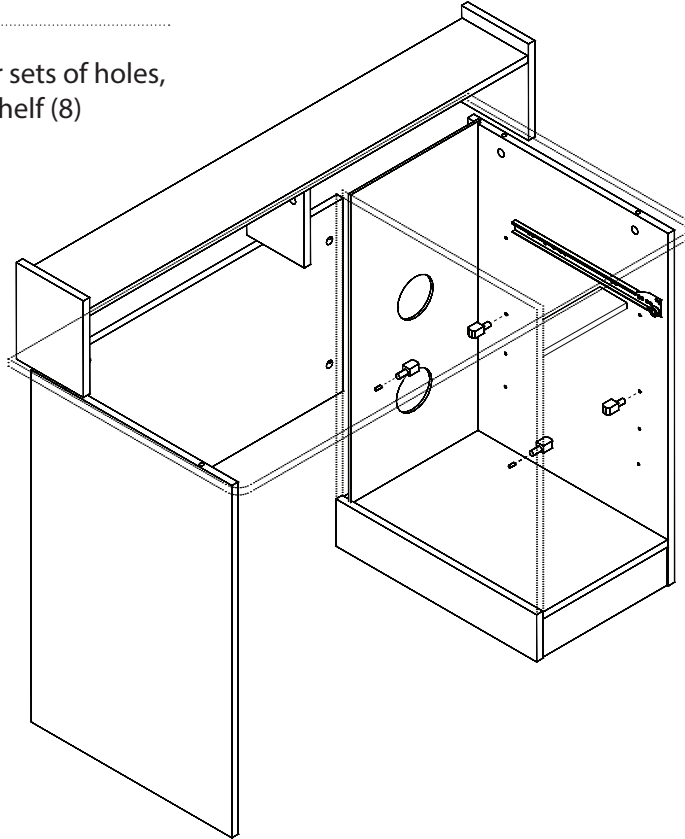
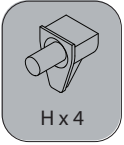

STEP 19

Align inner and outer rollers to insert drawer and keyboard tray.

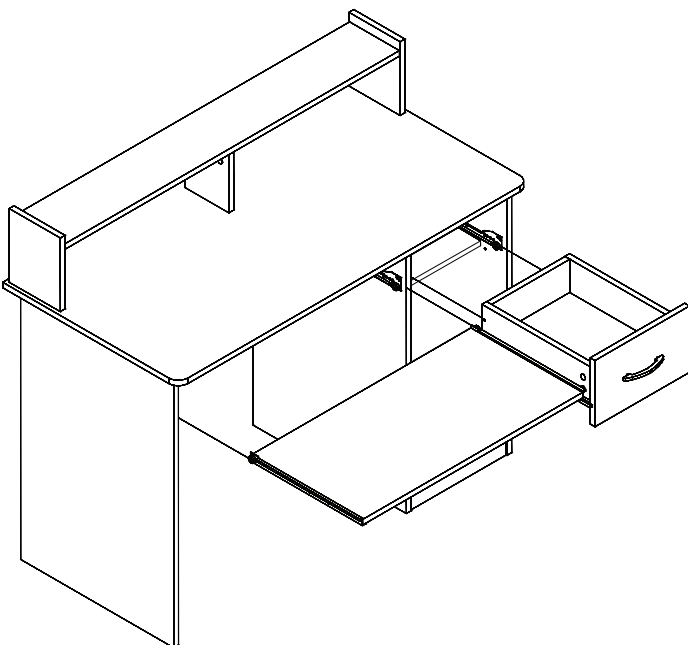

STEP 20

Place plastic caps (22) over cams at the back of the desk and cams in the hutch middle board (20).

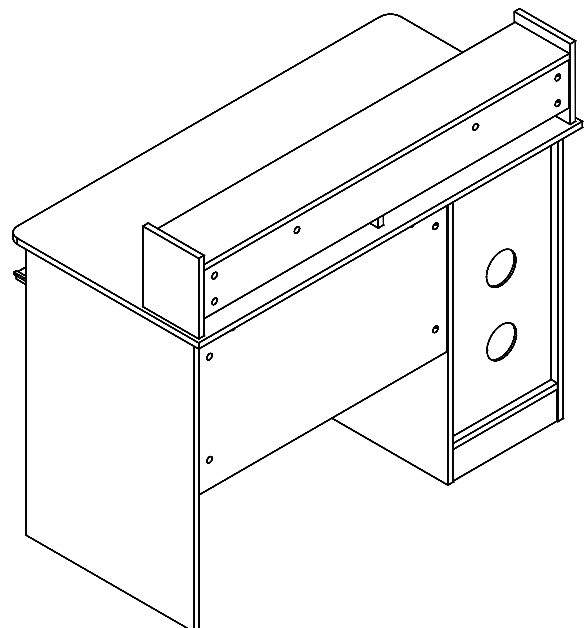

SAFETY AND MAINTENANCE

- DO NOT stand on the desk. Do not use the desk as a stepladder.
- DO NOT use the desk unless all bolts and screws are firmly secured.
- Every 6 months, check all bolts and screws to ensure they are tight.
- This product is California 93120 Compliant for Formaldehyde.

LIMITED WARRANTY

PLEASE VISIT WWW.COMFORTPRODUCTS.NET FOR WARRANTY INFORMATION

Comfort Products warrants this product to be free from defects in material and workmanship for one (1) year. This warranty is made by Comfort Products only to the original end-user customer acquiring the product directly from Comfort Products' authorized dealers as shown by the original sales receipt. The end-user customer remedy pursuant to this warranty is limited to repair or replacement of parts at Comfort Products' option within a reasonable amount of time. Comfort Products reserves the right to require damaged parts to be returned to Comfort Products upon request. Consent from Comfort Products must be obtained before any warranty work is performed. This warranty applies under conditions of normal use and is not subject to defects caused by improper assembly or disassembly; defects occurring after purchase due to product modification, intentional damage, fire, misuse, negligence, or exposure to the elements; labor or assembly cost. This warranty does not cover the cost of transportation or labor. In no event shall Comfort Products be liable in either tort or contract for any loss or direct, special, incidental, consequential or exemplary damages. This Limited Warranty is NOT applicable to end-user customers who use Comfort Products for rental purposes. This warranty applies only to end-user customers in the United States. All warranties are limited to the original purchaser for normal use. The weight capacities are defined as 165 pounds for the desktop, 11 pounds for the drawers, 22 pounds for the middle shelf, 44 pounds for the bottom shelf, and 22 pounds for the hutch. For claims or questions concerning this warranty, please visit: www.comfortproducts.net or email us at: customerservice@comfortproducts.net

MODEL: # 50-LD0101

Comfort Products, Inc.
122 Gayoso Avenue, Suite 101
Memphis, TN 38103
www.comfortproducts.net
email: customerservice@comfortproducts.net



OneSpace™

OneSpace is a Trademark of Comfort Products, Inc.