

SAVE THIS MANUAL FOR FUTURE REFERENCE

TABLE OF CONTENTS

Product Specifications	2	Maintenance.....	3	Storage	11
..... 10 Symbols					
Safety Warnings	4 - 5	Troubleshooting			
..... 11 Assembly 6 - 7	Warranty		
		 12		
Operating	8 - 9				

PRODUCT SPECIFICATIONS

Model: TC70010

Power supply voltage:	120V-60HZ	Working width:	11-IN or 16-IN
Tine Speed:	360 RPM	Working depth max:	8-IN
Power Consumption:	13.5 Amp		

1

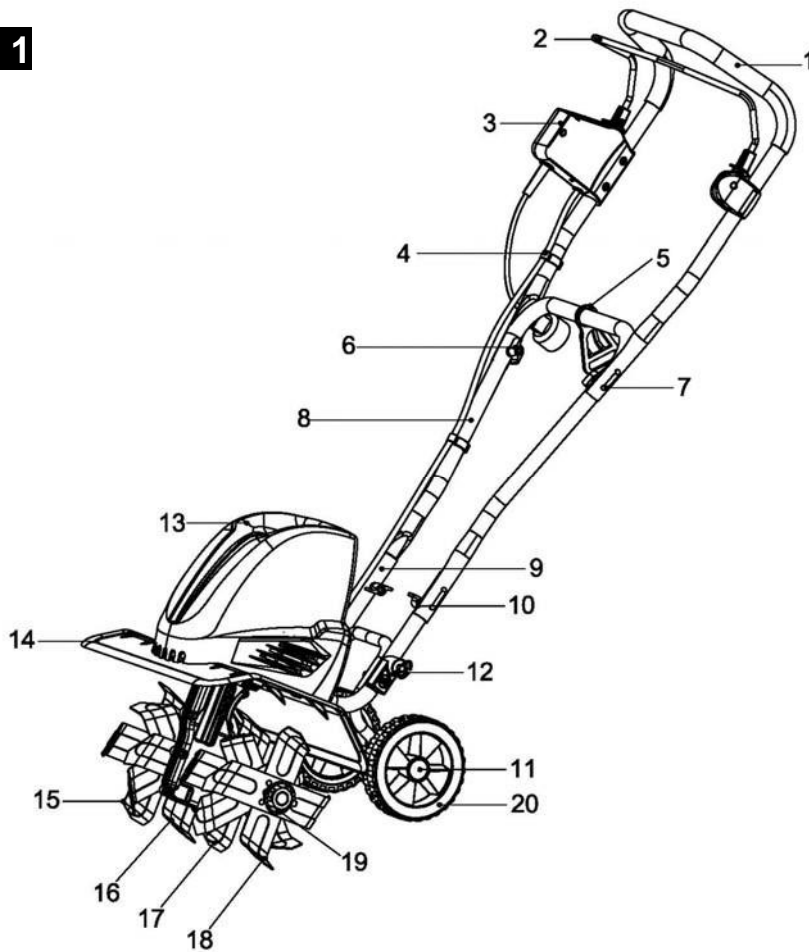

No.	Description (P/N)	No.	Description (P/N)
-----	-------------------	-----	-------------------

1	Upper handle section (RTC70016-01)	11	Wheel hub cap (RTC70016-60)
2	Bail wire (RTC70016-17)	12	Wheel frame lock pin (RTC70016-10)
3	Switch box and power cable assembly (RTC70016-02)	13	Motor housing (RTC70016-24)
4	Cable clip (RTC70016-03)	14	Protective shield (RTC70016-33)