



QUIETwarmth[®]

Radiant Heat Film for Under Subfloors

INSTALLATION AND OPERATION INSTRUCTIONS

CAUTIONS:

THIS EQUIPMENT SHALL BE INSTALLED ONLY BY QUALIFIED PERSONNEL WHO ARE FAMILIAR WITH THE CONSTRUCTION AND OPERATION OF THE APPARATUS AND THE RISKS INVOLVED.

THE INSTALLATION OF THIS HEATING PRODUCT SHALL BE IN ACCORDANCE WITH THE MANUFACTURER'S INSTRUCTIONS AND LOCAL AND NATIONAL CODES.

WARNING - AS DESCRIBED IN THESE INSTRUCTIONS, LEAD WIRES ARE NOT TO BE ROUTED OVER PADS OR COME INTO CONTACT WITH THE HEATING ELEMENTS AS DAMAGE TO SUPPLY CONDUCTOR INSULATION MAY OCCUR IF CONDUCTORS ARE ROUTED TO CONTACT HEATING ELEMENTS. REFER TO INSTALLATION INSTRUCTIONS FOR RECOMMENDED MEANS OF ROUTING SUPPLY CONDUCTORS.

THE TYPE AND THICKNESS OF FLOOR COVERING MATERIALS USED WITH THIS PRODUCT MUST NOT EXCEED A THERMAL INSULATION "R" VALUE OF 2.0.

CAUTION: USE COPPER ONLY AS SUPPLY CONDUCTORS. THERE ARE NO SPECIAL CRIMPING TOOLS REQUIRED FOR THIS PRODUCT.

MPglobal[™]

NALFA
NORTH AMERICAN LAMINATE
FLOORING ASSOCIATION

nwfa
National Wood
Flooring Association

RPA
MEMBER

w f c a
WORLD FLOOR COVERING ASSOCIATION

ICNA
INTERNATIONAL
CERAMIC TILE AND
STONE ASSOCIATION



QUIETwarmth®

QuietWarmth® Radiant Heat Film for Under Subfloors
Installation and Operation manual

2500 Old Hadar Road
Norfolk, NE 68702
888-379-9695 • FAX 402-379-9737
INFO@quietwarmth.com

Copyright © 2021 QuietWarmth®
REV 0121

QUIETwarmth®

RADIANT HEAT FILM FOR UNDER SUBFLOOR

INTRODUCTION AND OPERATION

The QuietWarmth® Radiant Heat system is a retrofit heating system that is installed under the subfloor, between the joists, to provide either primary or supplementary heat. Completely unseen, under subfloor heating panel sets warm floor surfaces to about 85°F / 30°C for unparalleled comfort.

Design, installation and use are straight-forward: start by designing the system, then cut the heating panel sets to length, staple them into position between the joists and complete the electrical connections.

Section 1 - Design Criteria is to be used by the heating system designer. This portion of the manual will generally be followed prior to ordering material. The designs and drawings completed during this stage must be made available to the installer(s).

Sections 2 - Job-Site Preparation, 3 - Installation and 4 - Inspection Testing & Completion will be used by the actual heating system installers. Job-Site Preparation provides a complete list of the materials and supplies that must be on hand during the installation and testing of the system. Installation and Inspection detail the actual installation and testing of the system.

CAUTION



THE INSTALLATION OF THIS HEATING PRODUCT SHALL BE IN ACCORDANCE WITH THE MANUFACTURER'S INSTRUCTIONS AND THE REGULATIONS OF THE AUTHORITY HAVING JURISDICTION.



The installation of this heating product shall be in accordance with Article 424, Part J, of the National Electrical Code, ANSI/NFPA 70.



THIS EQUIPMENT SHALL BE INSTALLED ONLY BY QUALIFIED PERSONNEL WHO ARE FAMILIAR WITH THE CONSTRUCTION AND OPERATION OF THE APPARATUS AND THE RISKS INVOLVED.



Heating elements should not be installed at or below 32°F (0°C).



QUIETwarmth[®]

LIMITED WARRANTY

MP GLOBAL PRODUCTS, LLC (THE “MANUFACTURER”) WARRANTS TO THE ORIGINAL PURCHASER (THE “OWNER”) THAT THIS RADIANT HEAT FILM FOR USE UNDER EXISTING FLOOR COVERING MATERIALS BETWEEN SUBFLOOR JOISTS IN AN ACCESSIBLE CRAWL SPACE OR BASEMENT (THE “PRODUCTS”) will be free of defects in workmanship and materials and will conform in all material respects to any written specification that the Manufacturer provided to that customer before the purchase.

If that customer believes that a shipment of product fails to satisfy the above warranty, that customer must (a) contact the Manufacturer in writing within 25 years after that customer receives the shipment, including a detailed explanation of the alleged nonconformity and (b) return the shipment to the Manufacturer postage prepaid. If The Manufacturer reasonably determines through examination of the returned shipment that the shipment did not satisfy the above warranty, then AS THE MANUFACTURER EXCLUSIVE LIABILITY AND THE CUSTOMER’S SOLE REMEDY, THE MANUFACTURER WILL, WITHIN A REASONABLE PERIOD OF TIME, REPAIR THE PRODUCT, REPLACE THE PRODUCT WITH THE SAME OR SIMILAR PRODUCT, OR CREDIT THE CUSTOMER’S ACCOUNT WITH THE PURCHASE PRICE, WHICHEVER THE MANUFACTURER MAY ELECT IN ITS SOLE DISCRETION. If the Manufacturer determines that the function of the Product caused the failure of the overlying finished floor covering, and installation instructions were properly followed during installation, the Manufacturer will repair or replace the finished floor covering at no cost to the customer.

This warranty does not apply if the Manufacturer reasonably determines that the product has been cut improperly, added to or otherwise altered, stored improperly, misused, damaged, or installed not in accordance with the instruction manual supplied by the Manufacturer. The Manufacturer requires that this product be used ONLY with approved control devices. Use of any other control device will render the provisions of this warranty null and void. This warranty covers only components manufactured by the Manufacturer. Components such as attaching hardware, connecting parts, wire, tape, and other items included in kits or assemblies that are not manufactured by the Manufacturer are excluded from the provisions of this warranty.

Except as expressly provided in this Limited Warranty, the customer is responsible for the cost of labor, service calls, insurance, shipping, installation costs and any other expense or damage incurred.

THE FOREGOING WARRANTY IS IN LIEU OF ALL OTHER REPRESENTATIONS, WARRANTIES, OR CONDITIONS, EXPRESS OR IMPLIED, INCLUDING WITHOUT LIMITATION ANY IMPLIED WARRANTY OF MERCHANTABILITY, FITNESS FOR A PARTICULAR PURPOSE OR NON-INFRINGEMENT, AND OF ANY OTHER OBLIGATION OR LIABILITY ON THE PART OF THE MANUFACTURER WHETHER BY STATUTE, CONTRACT, STRICT LIABILITY, TORT OR OTHERWISE.

THE MANUFACTURER IS NOT RESPONSIBLE FOR ANY INCIDENTAL, CONSEQUENTIAL, MULTIPLE, PUNITIVE OR INDIRECT DAMAGES OR LOSS, LOSS OR DAMAGE TO OR LOSS OF USE OF FACILITIES OR OTHER PROPERTY, OR FOR LOST PROFITS OR LOST REVENUE, WHETHER BASED UPON WARRANTY, STATUTE, CONTRACT, STRICT LIABILITY, TORT OR OTHERWISE. THE MANUFACTURER SHALL IN NO EVENT BE LIABLE FOR THE PERFORMANCE OF, OR COST OF PERFORMING, THE REMOVAL OR INSTALLATION OF THE PRODUCT OR ANY PRODUCT OR MATERIAL INTO WHICH IT IS INSTALLED, INCORPORATED OR ADDED. THE CUSTOMER IS RESPONSIBLE FOR THE COST OF LABOR, SERVICE CALLS, INSURANCE, SHIPPING, INSTALLATION COSTS AND ANY OTHER EXPENSE OR DAMAGE INCURRED.

IN NO EVENT SHALL THE MANUFACTURER’S MAXIMUM LIABILITY EXCEED THE PURCHASE PRICE FOR THE RELEVANT SHIPMENT OF PRODUCT, EXCEPT TO THE EXTENT MADE MANDATORY BY LAW.

SAFETY INFORMATION

Throughout the manual you will see Cautions and Notes. These notices highlight conditions, procedures, or other information that require special attention to prevent damage to the mats, to your flooring, or possible injury. For a safe and functional installation of QuietWarmth® Radiant Heat, read and follow these important safety precautions. Failure to comply with these items may result in injury or damage to the mats.

This information must be read and understood by all technicians who will be working in the area of an installed QuietWarmth® Radiant Heat or main electrical systems. Failure to follow these guidelines may result in a risk of electric shock or fire hazard.



Indicates precautions or procedures that should be followed to prevent the possibility of fire.



Indicates precautions or procedures that should be followed to prevent the possibility of electrical shock.



Indicates an item that you should pay special attention to. For example, notes are used to highlight installation tips.



Make sure that the jobsite is neat and clean before working with the system. Nails, screws, and other sharp debris can damage the mats creating a potential shock hazard. Any mats which become torn or otherwise damaged must be discarded.

Ensure that the breaker supplying power to the heating mats has been turned off before making electrical connections.

When installing any other materials on or near a heated floor, ensure that no heating mats are punctured by nails, screws, etc.



Flooring materials must be rated for use with electric floor warming system.

Do not fold or alter the heating mats.

Do not place futons, beanbag chairs, or similar furniture on heated floors.

SECTION 1. Design Criteria

The QuietWarmth System is made up of 4 major components: the heating panels, the wiring, the control device and the building structure. These components work together to create a system that will provide comfortable, trouble-free heat. The selection and installation of each component is very important to the system's overall safe operation.

Designing a QuietWarmth System is straightforward — the following instructions must be complied with to ensure a trouble-free design and to comply with the warranty requirements.



NOTE:

A Planning Guide is available to assist installation layout of the mats. See back of this manual for more.

Heat Loss Calculation

If the Warm Floors System is to be used as a primary heating system for a room, a heat loss calculation must be completed to determine the energy required to adequately heat the space under foreseeable circumstances. The Air Conditioning Contractors of America (ACCA) Manual J includes worksheets for manually calculating the heat loss of a structure. Other, comparable, heat loss methods and/or documents may be used. Make sure that all sources of heat loss (transmission, infiltration and radiant) are taken into account.

Most bathrooms and some kitchens have small available floor areas relative to the volumes of the rooms, the maximum possible amount of installed heat is often insufficient to supply the demand. Bathrooms and other areas where there is not enough available floor space to allow installation of sufficient QuietWarmth heating panels to act as a sole source of primary heat must use a supplementary or alternative heat source, such as high power radiant panels, baseboard heaters, etc.



NOTE:

Some heat loss methods, particularly those designed for gas and oil based systems, provide their answers in Btus per hour. To convert Btus per hour to watts, multiply each area total by 0.293 (or divide by 3.41).

Always include a recovery factor of at least 20% more than the mini-mum calculated heat requirement to cover unforeseen circumstances.



CAUTION:

A separate heat loss calculation must be done for each enclosed area (room, etc.). A separate control device must be included for each enclosed area.

Do not install as a primary heating system in any bathroom, room or other area which does not have at least as much heat installed as is called for by the heat loss calculation, plus the recovery factor.

Control Device Options

The fuse or circuit breaker used must be rated for a maximum of 20 amperes (no greater than 15 amp load). If a lower rated fuse or circuit breaker is used, it must be rated at least 25% greater than the heating system load attached to it. If an area requires more than the 15 amperes allowed, additional branch circuits may be used, each having its own overcurrent protection. These branch circuits may all be controlled by a single thermostat if it is used with a system of electric relays or power modules.



CAUTION:

All wiring, fuses and/or circuit breakers must conform to National Electrical Code. Metal joists must be properly grounded in accordance with local codes.



NOTE:

The National Electrical Code specifies that each branch circuit used in conjunction with a heating system must be for the exclusive use of the heating system. Do not connect lights, outlets, etc. to any branch circuit used with the QuietWarmth System.

The selection of a control device will be determined by the designed use of the system. If installed and used as a primary heating system, a thermostat must be used. If designed to be used as a supplemental or floor warming system, timers or other control devices also may be used. Whichever control option is used, all components must meet all applicable local and national codes and be rated for use with an electrical heating system.

Floor Construction

Joists: The QuietWarmth System is designed for use with typical wood and/or metal floor joists. The joists must have a facing width no greater than 2 inches / 50 mm with a spacing between the joists strips of 16 inches on center / 400mm. ****Currently only 16" on Center Panels are available.***

Floor Surface: The floor surface may be of any material having a total thermal insulation value of less than R-11 / RSI-2 — this includes any floor finish such as tile, hardwood, carpet, as well as secondary materials added to the floor at a later time. Contact the material manufacturer for specific information concerning the thermal insulation factor of the material being specified.

Surface Finish: Any type of surface finish can be applied to the finished floor — the total thermal insulation value of the sub-floor and floor finish must not exceed R-11.



NOTE:

Do not use the System to cure adhesives, stains or paints since direct heat during curing may cause cracks or discoloration.

Heating Panels

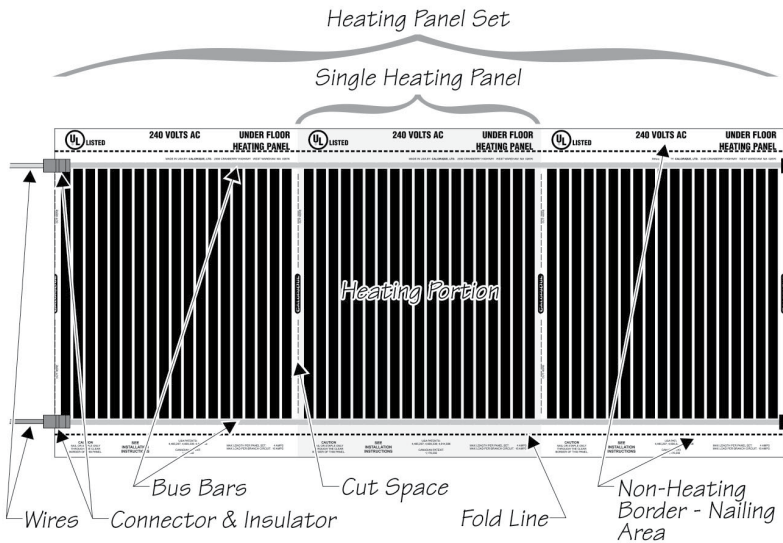

A typical QuietWarmth heating panel set.

The QuietWarmth System is available in three standard widths, and two standard voltages. The following table shows the maximum number of single panels that a thermostat can control for each width and voltage. If your project requires more single panels than indicated in the table below, additional thermostats or power modules will be required:

JOIST SPACING	WATTS / PANEL	120 VOLTS AC	240 VOLTS AC
16 inch / 400 mm	10	180 panels	360 panels



NOTE:

If a particular room or area includes more than one joist spacing (e.g. some joists spaced at 12 inches and some spaced at 16 inches), you must use the appropriate heating panel for each joist spacing.

SECTION 2. Jobsite Preparation

Before work can proceed, all plumbing and electrical wiring that will not be accessible after installation of the heating system must be completed. This may require coordinating with the electrical and/or plumbing contractor(s).

Make sure that insulation has been installed in areas that will be inaccessible after installation of the heating system. This may require coordinating with the insulation contractor. Before installing the QuietWarmth System, all of the following must be available at the job-site.



CAUTION:



Make sure that the jobsite is neat and clean before working with the QuietWarmth radiant heating panel sets. Nails, screws and other sharp debris can damage the panels. Any panels which become torn or otherwise damaged must be discarded. If insulation is being installed by another contractor, this information must be made available and compliance ensured. Use copper only as supply conductor.

Additional Components

NAME	PART	DESCRIPTION
Thermostat/Control	---	UL Listed thermostat or other appropriate control rated for at least 25% greater capacity than the installed heating load. Thermostat w/Floor Sensor is recommended.
Thermal Insulation	---	The insulation must be of the non-flammable type specified during calculations done per Part 1. See for details.
Dielectric Tape	---	UL listed and/or CSA certified “electrical” tape rated for at least 90°C / 194°F.
Ohm-Meter or Multi-Meter	---	An accurate ohm-meter or multi-meter must be used during the testing phase to ensure that the system is correctly installed. It is suggested that a digital meter is used rather than an analog (needle) type.
Staple Gun	---	Standard automatic stapler. Used to attach QuietWarmth panels to floor joists. Recommended staple length: 5/16 or 3/8 inch / 8 or 9.5 mm.
Assorted Hand Tools	---	Conventional electrical wiring hand tools.
Scissors	---	Used to cut heating panel sets to length if needed.
System Warning Labels	CW1007 CW1009 CW1011	These labels are an integral part of this heating system and must be installed for the warranty to be in force. See page 14 for details on affixing these labels. One of each type label is provided for each 16 meters of heating panels (50 panels).

SECTION 3. Installation

Install the control device box

Install a junction box for the control device. If this device is a thermostat, the box should be located, unobstructed, on an insulated inside wall so that the device reads accurately.

Prepare the heating panels

Prepare all heating panels for each room at one time prior to starting installation. Test each mat with ohms meter for resistance readiness. Record the resistance readings in the included chart

1. Cut the panel(s) to length (if needed). Using a knife or scissors, cut panel sets according the layout made in Part 1. Ensure to cut full single panels - never cut a partial panel.

2. Insulate the cut other end of each bus bar on panel opposite the lead wires. Place a length of electrical tape over the exposed end of each bus bar opposite the electrical connector.

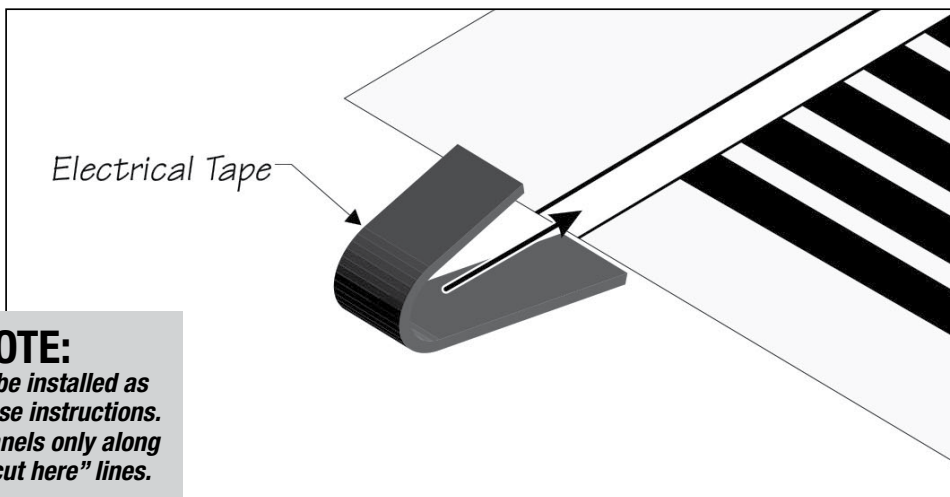

NOTE:

Panels must be installed as outlined in these instructions. Cut heating panels only along the dashed "cut here" lines.

DO NOT remove partial panels

Attach heating panel sets to joists

1. Align a heating panel set with one of the joists to which it will be attached. Make reference to the layout made in Part 1 for heating panel locations.
2. Nail or staple the panel set in place, leaving at least 6 inches / 150 mm clearance to walls or partitions at the connector end for wiring and final assembly. Nail or staple as close to the perforated bending line as possible, keeping the edge of the panel set straight along the top edge of the joist. Nails or staples must be placed at least once every 12 inches / 300 mm along each side of the heating panel set.



NOTE:

To insure efficient operation of heating panel, please leave an air gap of 2" or 50 mm between the heating panel and subfloor.

3. Fold the heating panel so that it runs level between the two joists and nail or staple the other side into position.
4. Repeat for each heating panel set, then continue to the next section, Wire the Heating Panel Sets.



CAUTION:



Do not pierce the panels within 3/8 inch / 10 mm of the bus bar or heating portion of the panel.

The heating panels must run smooth and flat between the joists. There must be no wrinkles in the heating panels. Heating panels must run parallel to the joists they are attached to.

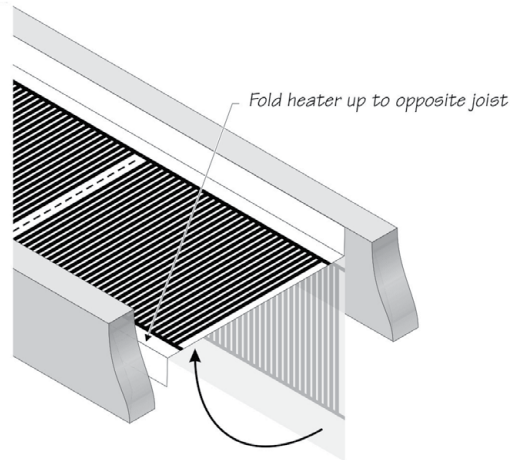
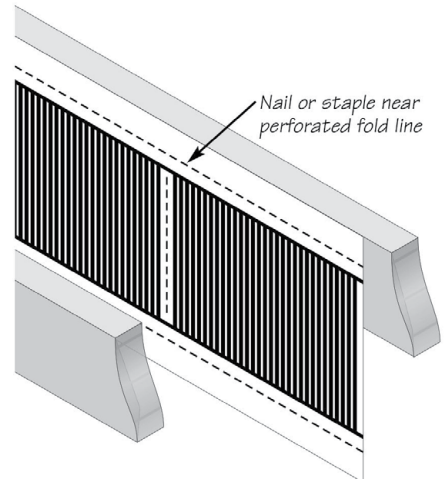

Wiring the heating panel sets

1. Once mats are installed properly, recheck mat resistance using Ohm Meter to ensure that no damage occurred.
2. Run all leads to a junction box. To make the appropriate connections, wire the heating panels in parallel.

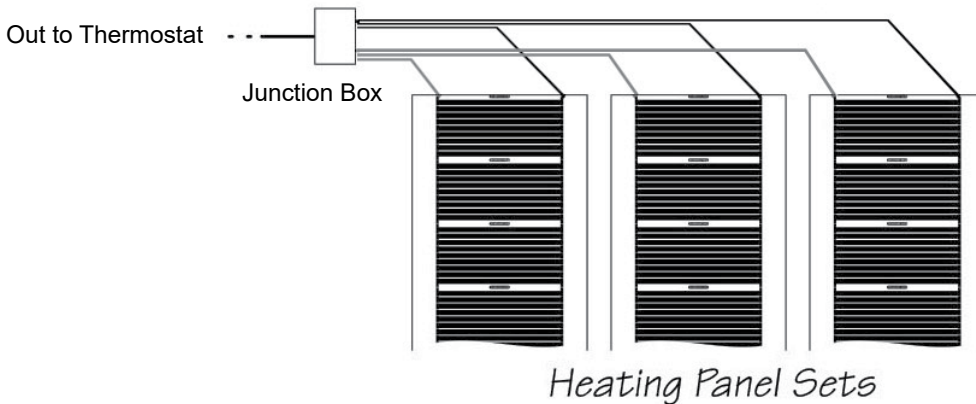
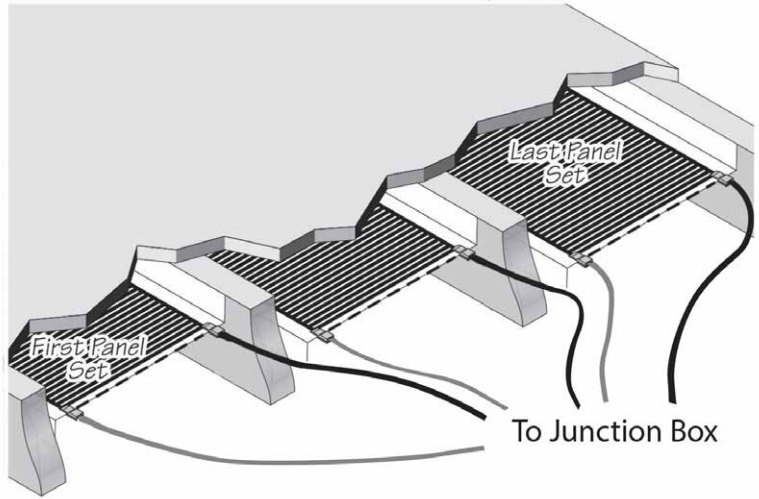

CAUTION:

Route and secure wires between the heating panels, from the heating panels to the thermostat box and from the thermostat box to the electrical panel using standard wiring practices that conform to all of the requirements of all applicable electrical and building codes.



CAUTION:

RISK OF ELECTRIC SHOCK AND FIRE DAMAGE TO THE SUPPLY CONDUCTOR INSULATION MAY OCCUR IF CONDUCTORS ARE ROUTED LESS THAN 2 INCHES (51 MM) FROM THIS HEATING PRODUCT. REFER TO INSTALLATION INSTRUCTIONS FOR FOR RECOMMENDED MEANS OF ROUTING SUPPLY CONDUCTORS.

Attach heating panel sets to joists

When using a floor sensing thermostat, the floor sensor must be installed correctly to control the floor temperature appropriately. It is important to install the sensor where the panels are placed for optimal control. The following are recommended options for installing the sensor. Other equivalent methods may be used.

Before installing the sensor, make sure to test it with an ohmmeter to ensure there are no factory defects, see the installation instructions of the thermostat for proper installation guidelines.

Option 1. A sensor may be difficult to place within some existing floors, the sensor may be placed under the subfloor. However, keep in mind that the temperature the sensor gives will not be a true floor surface temperature and the floor-sensing control may need to be adjusted accordingly.

The most accurate method is to drill $3/4"$ to $1"$ long hole at an angle into the bottom of the subfloor (drilling at an angle prevents puncturing through floor surface). Locate this hole in a joist bay directly over where a joist panel will be installed, about $2"$ from the joist. Insert the sensor into the angled hole and seal it with adhesive. Insulate the sensor with additional insulation. This will isolate the sensor from the heated joist space and give a more accurate floor surface temperature.

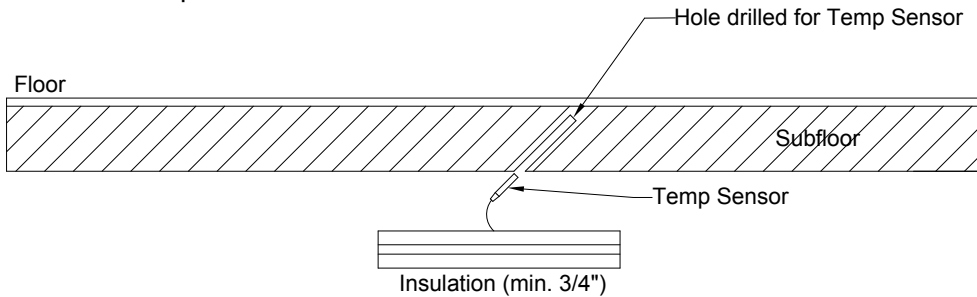

Option 2. If it is not possible to drill a hole to set the sensor in the subfloor, it may be held flat to the subfloor with a nylon wire clip. Locate the sensor in a joist bay directly over where a mat will be installed, about $2"$ from the joist. Insulate the sensor with additional insulation. This will help isolate the sensor from the heated joist space.

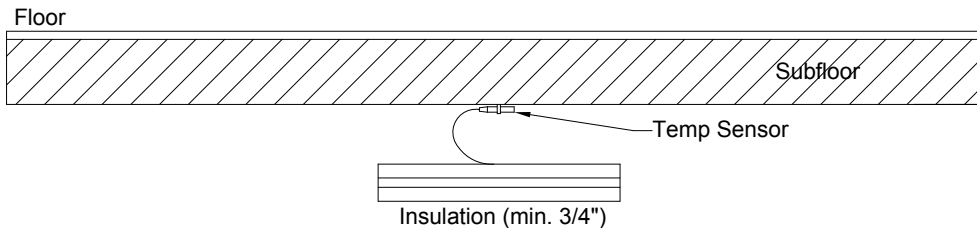

Option 3. If possible, install the sensor directly into or under the floor covering area. For example, if the existing floor covering is tile, an existing grout line can be removed and the sensor laid into this grout line. Place the sensor at least 1 ft. from outside walls and near the center of a joist space. Complete the rest of the installation before covering or regrouting over the sensor.

SECTION 4. Inspection/Testing/Completion

Visual Inspection

When visually checking the panels, look for any signs of damage, wear or scratching that might have occurred during installation. If any portions of a panel set appear damaged, replace the entire panel set.

Electrical Test

A resistance check across the supply leads using an accurate ohm meter must be made to detect defects to the system — record the resistance readings. Use the resistance chart in the operating manual to determine the acceptable readings. Readings should be taken before attaching to joists to ensure no damage occurs to the panels during installation.

16" On Center Width 120V

No of Panel(s)	Wattage	CURRENT (AMP)	High Resistance Limit (ohms)	Low Resistance Limit (ohms)
1	10	0.0833	1584	1368
2	20	0.166	792	684
3	30	0.25	528	456
4	40	0.333	396	342
5	50	0.416	316.80	273.60
6	60	0.5	264	228
7	70	0.583	226.28	195.42
8	80	0.666	198	171
9	90	0.75	176	152
10	100	0.833	158.4	136.8
11	110	0.9166	143.99	124.36
12	120	1	132	114
13	130	1.08	121.84	105.23
14	140	1.166	113.14	97.7
15	150	1.250	105.6	91.20

16" On Center Width 240V

No of Panel(s)	Wattage	CURRENT (AMP)	High Resistance Limit (ohms)	Low Resistance Limit (ohms)
1	10	0.042	6336.00	5472.00
2	20	0.083	3168.00	2736.00
3	30	0.125	2112.00	1824.00
4	40	0.167	1584.00	1368.00
5	50	0.208	1267.20	1094.40
6	60	0.250	1056.00	912.00
7	70	0.292	905.14	781.71
8	80	0.333	792.00	684.00
9	90	0.375	704.00	608.00
10	100	0.417	633.60	547.20
11	110	0.458	575.99	497.45
12	120	0.500	528	456
13	130	0.541	487.38	420.92
14	140	0.583	452.57	390.85
15	150	0.625	422.50	364.80

To determine the total installed watts, multiply the number of individual heating panels by the wattage per panel for each type of panel. After any remedies (below) have been performed for open or short circuits, if any, retest the system.

Reading	Indication	Action
Between high & low resistance limits	Good	System is connected properly. No action is necessary.
Higher than high resistance limit	Open Circuit	Check all electrical connectors and retrim or replace any that are attached improperly.
Zero (0)	Short Circuit	Check the path that the wiring is taking and make sure that no wires are attached to both bus bars of a single panel. If any are, remove the wires

Complete the installation

- 1. Install control device and connect to electrical panel box.** Install and wire the control device according to manufacturer's instructions in the junction box added at the beginning of Part 3 — Installation. Now, depending upon your wire lead installation, run the lead wires from the individual mat(s) along the base of the wall and up to the junction box. Wire the heating mats to the control according to the manufacturer's instructions using the 12/2 Romex wire.
- 2. Install thermal insulation.** The insulation may be installed in the normal manner.
- 3. Finish the floor in any normal fashion.**
- 4. Install a floor covering in accordance with the designer's notes.**

 **CAUTION:**
Any material used as a floor surface
must be appropriate

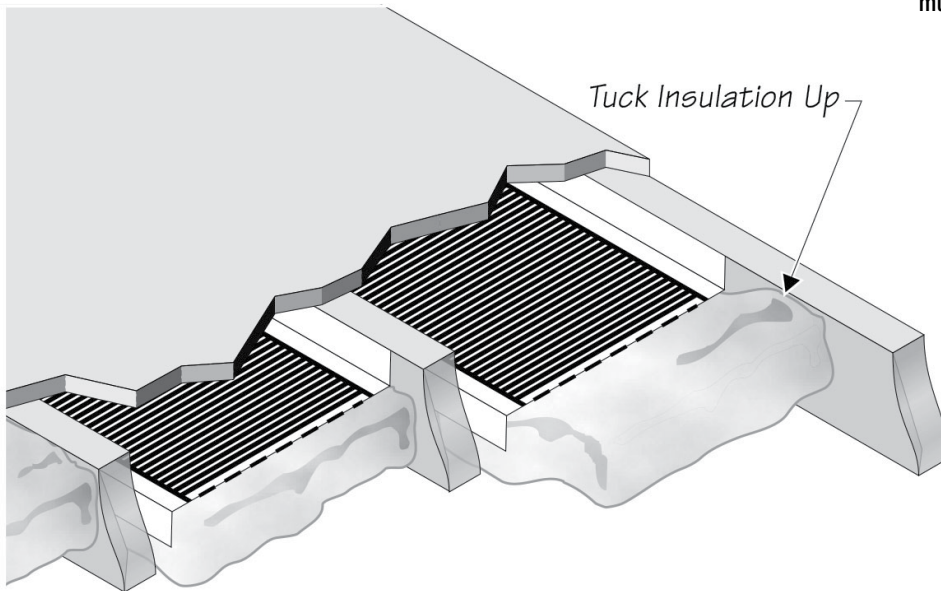

NOTE:

The system labels are an integral part of the heating system and must be attached as noted here. Failure to attach system labels is in violation of the warranty and may result in revocation of the warranty.



NOTE:

Tuck insulation up at the end of each panel set so that it seals in the heating panel set. This will help keep heat from escaping and improve the efficiency of the system.

Complete the installation

5. Attach system warning labels in the locations noted. These labels are an integral part of this heating system and must be installed for the warranty to be in force. One of each type label is provided for each 16 meters of heating panels



CW1007: Affix to the electrical panel box. In the space provided, record the numbers of all circuits to which floor heating panels are attached.



CW1009: Affix adjacent to points of access to all con-cealed areas in which installed heating products are accessible.



CW1011: Affix to all devices controlling radiant heat (thermostat, switch, etc)

Documentation

The System Checklist and Warranty Registration form records vital information about your QuietWarmth™ installation. Fill out all requested information on BOTH copies. One copy is returned to the manufacturer to register the installation, and the second copy is for the homeowner's records.

This manual must be attached to the service panel so that it is easily accessible to the homeowner and any repair technicians.



System Checklist and Warranty Registration

Installation Location: _____ Name of Installer: _____
 City / State / ZIP / Country: _____ Installer Company Name: _____
 Installation / Inspection Dates: _____ / _____ Street Address: _____
 Purchase Order Number: _____ City / State / ZIP / Country: _____
 Purchased From: _____ Heat Loss Calculated by: _____
 Electrical Permit Number: _____ Electrical Inspector: _____
Floor warming systems being used as primary heat require heat loss calculation.
 Floor warming systems used as supplemental heat do not require heat loss calculation.

Provide All Requested Information For Each Room / Area

Design Criteria				Inspection				
Primary Heat: yes no if "yes": Heat Loss +20%	Product Model Number (s)	Number of Mats & Sizes	Total Number of Installed Watts	Visual Inspection*	Product Date Code**	Number of Thermostats	Voltage	Ohm Reading
				A <input type="checkbox"/> B <input type="checkbox"/> C <input type="checkbox"/>				
Living Room				A <input type="checkbox"/> B <input type="checkbox"/> C <input type="checkbox"/>				
Dining Room				A <input type="checkbox"/> B <input type="checkbox"/> C <input type="checkbox"/>				
Entrance				A <input type="checkbox"/> B <input type="checkbox"/> C <input type="checkbox"/>				
Kitchen				A <input type="checkbox"/> B <input type="checkbox"/> C <input type="checkbox"/>				
Family Room				A <input type="checkbox"/> B <input type="checkbox"/> C <input type="checkbox"/>				
Bedroom 1				A <input type="checkbox"/> B <input type="checkbox"/> C <input type="checkbox"/>				
Bedroom 2				A <input type="checkbox"/> B <input type="checkbox"/> C <input type="checkbox"/>				
Bedroom 3				A <input type="checkbox"/> B <input type="checkbox"/> C <input type="checkbox"/>				
Bathroom 1				A <input type="checkbox"/> B <input type="checkbox"/> C <input type="checkbox"/>				
Bathroom 2				A <input type="checkbox"/> B <input type="checkbox"/> C <input type="checkbox"/>				
Den				A <input type="checkbox"/> B <input type="checkbox"/> C <input type="checkbox"/>				
Other				A <input type="checkbox"/> B <input type="checkbox"/> C <input type="checkbox"/>				
Panel Box ***				D <input type="checkbox"/> E <input type="checkbox"/> F <input type="checkbox"/>				
Total								

* Visual Inspection: A — No Installation Damage such as creasing, punctures, cuts or abrasions.
 B — Control / Thermostat Warning Label has been installed.
 C — Insulation Type and Thickness corresponds to specifications.
 ** Date Code: The product date code is a 3 letter, 6 number code printed in the center of the element (except tile mats).
 *** Panel Box: D — Warning Label is attached to panel box. E — All Circuits Properly Labeled.
 F — Heating System Circuit For Exclusive Use of the Heating System (no outlets, etc.).

QuietWarmth
 2380 Cranberry Highway
 West Wareham, MA 02576

The undersigned represents that the above installation has been performed in accordance with the installation instructions and all applicable codes and that all of the above statements are true, correct and complete. A copy of this form must be kept on site as a permanent record.

NAME (please print) _____ SIGNATURE _____ DATE _____

Completely fill out information and return one (1) copy to:

Sketch Grid

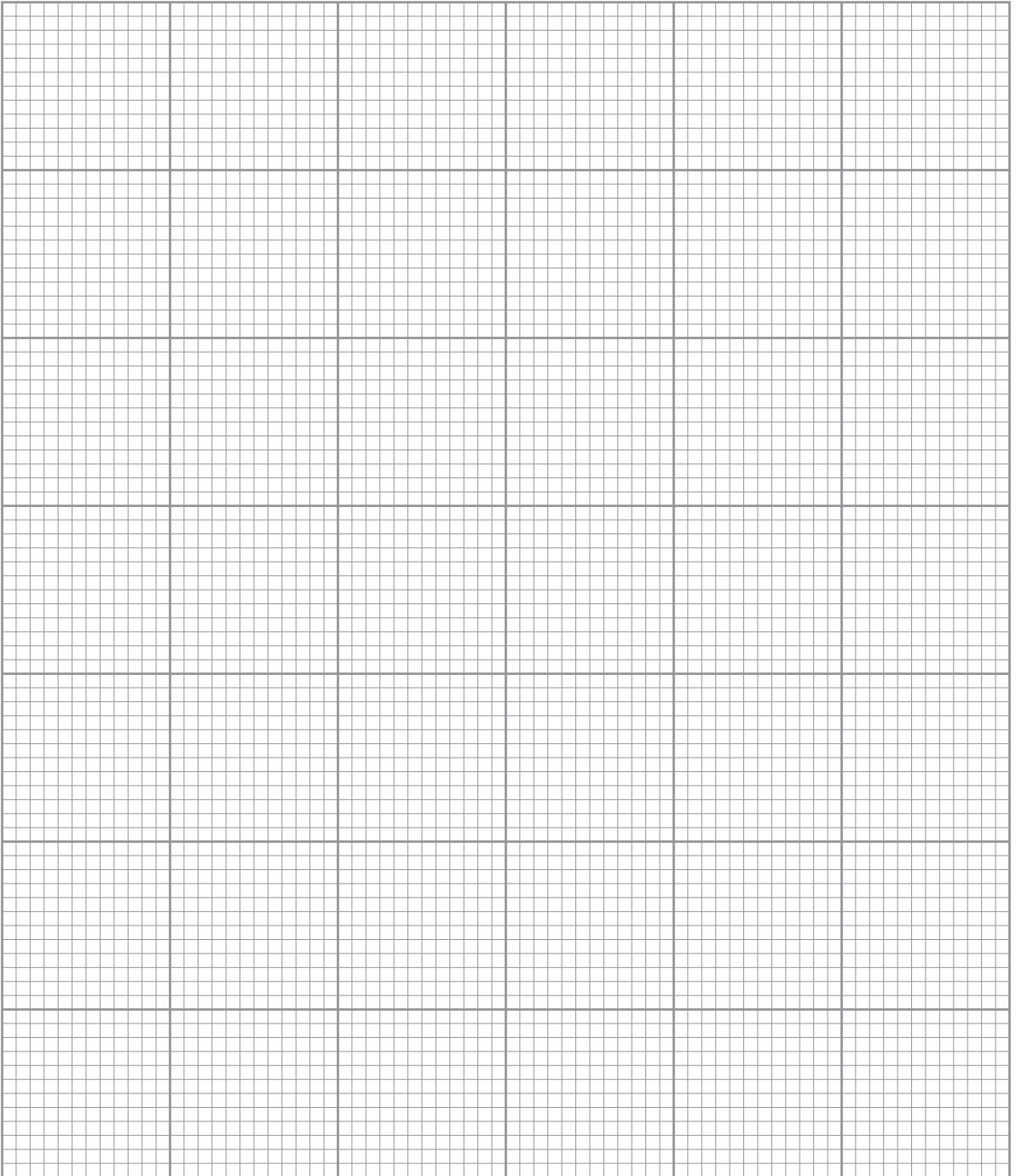



QUIETwarmth®

Radiant Heat Film for Under Subfloors

2500 Old Hadar Road

Norfolk, NE 68702

888-379-9695 • FAX 402-379-9737

INFO@quietwarmth.com

Copyright © 2021 QuietWarmth®

REV 0121