

K-9 Kamp Assembly Instruction

Model: 2660

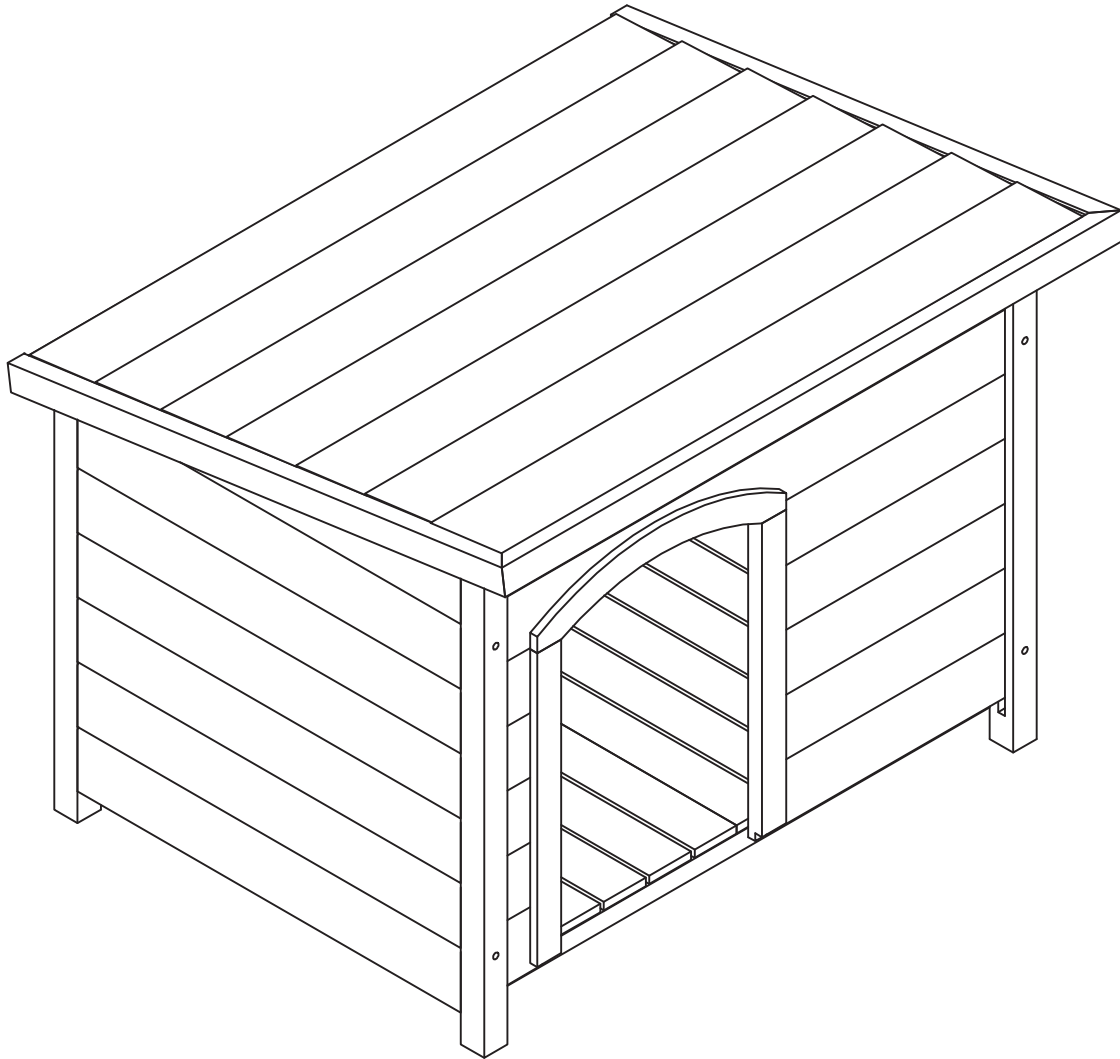
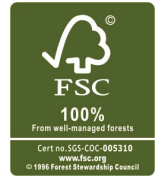

WARNING: CHOKING HAZARD

Unassembled parts may be a choking hazard to children 3 years and younger. The plastic bags that contain the hardware may present a choking hazard to small children. Please keep these bags and all plastic bags out of the reach of children. Do not allow children to play with them and dispose of them immediately when empty.



CAUTION: Adult Assembly Required

Hardware contains small pieces with sharp points. Keep parts out of the reach of children until assembled. Parts of this product can present dangers if improperly assembled

Creative Cedar Designs
www.creativecedardesigns.com

Customer Service:
Please log onto our website and fill out
a request for missing / damaged parts.
email: custservice@creativecedardesigns.com
phone: 1-888-363-4967

Revision Date: 10/28/2019



CREATIVE CEDAR DESIGNS

Basic Setup Dimensions

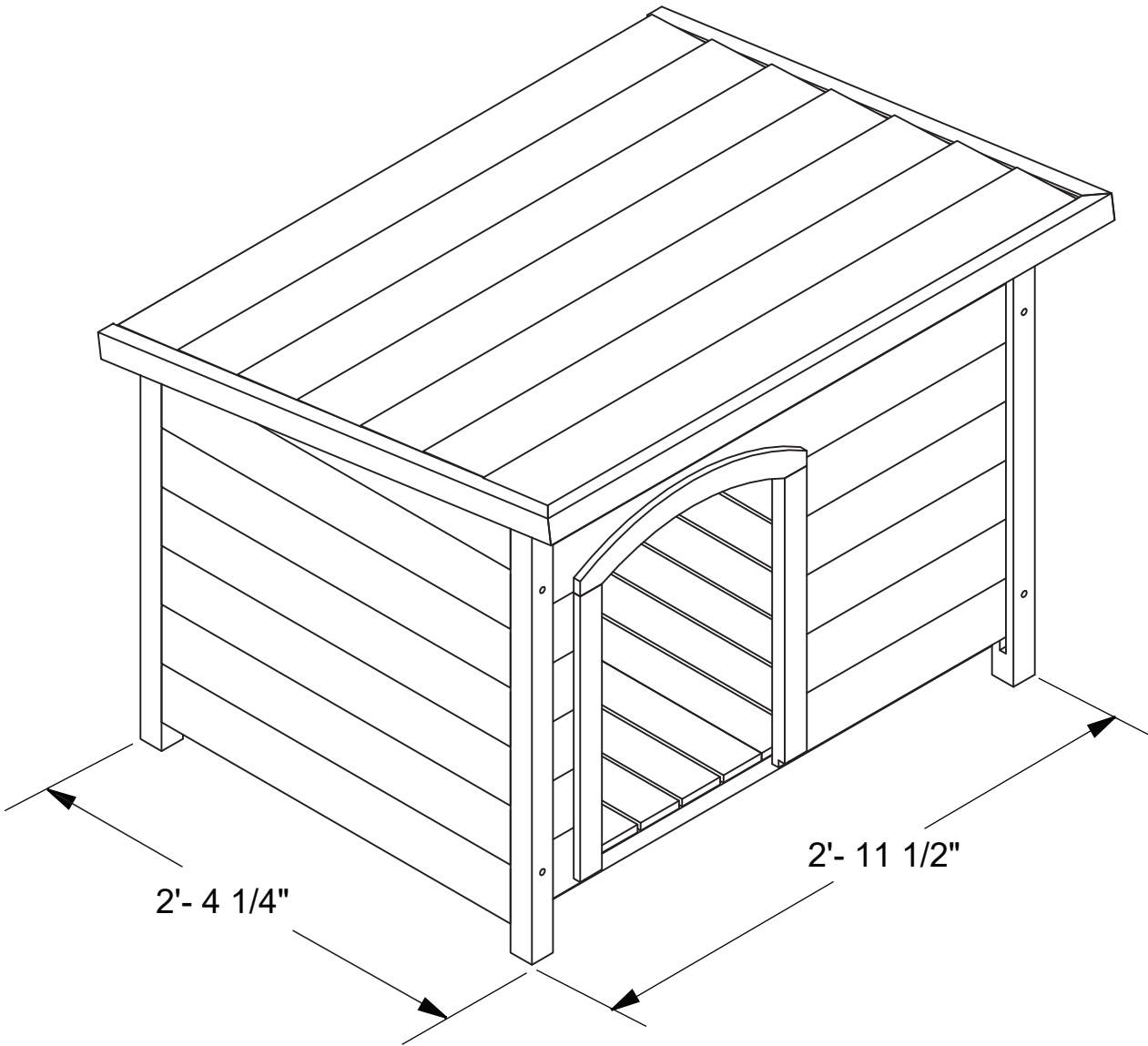

HEIGHT=2'- 2 5/8"

PARTS LIST

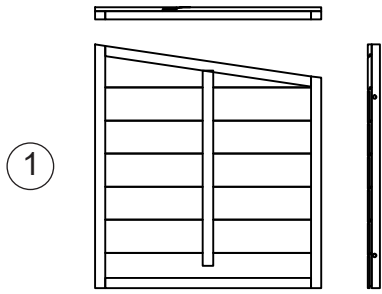

1

LEFT WALL ASSEMBLY
(1 REQ.)

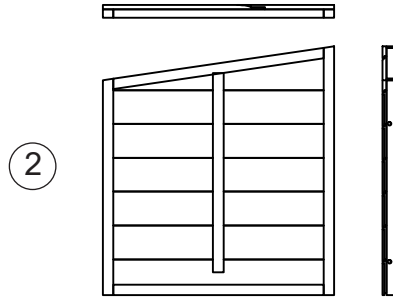

2

RIGHT WALL ASSEMBLY
(1 REQ.)

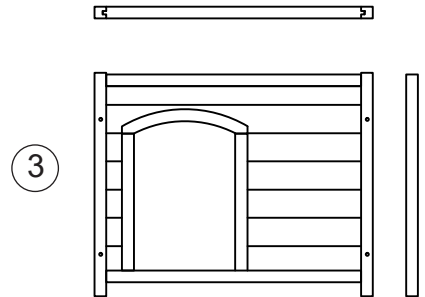

3

DOOR WALL ASSEMBLY
(1 REQ.)

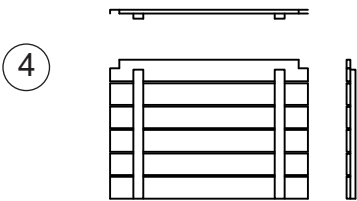

4

FLOOR SECTION ASSEMBLY
(2 REQ.)

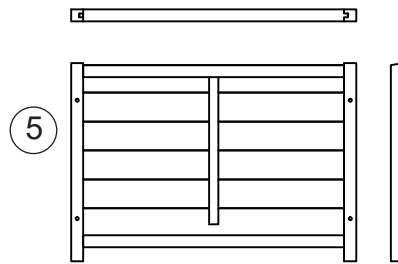

5

BACK WALL ASSEMBLY
(1 REQ.)

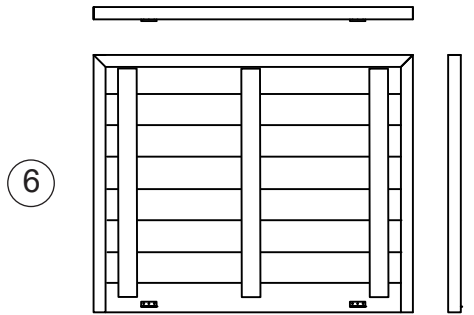

6

ROOF ASSEMBLY
(1 REQ.)



7

LEFT HINGE
(1 REQ.)



8

RIGHT HINGE
(1 REQ.)

HARDWARE LIST

1/4"X2 1/4"Socket Head Bolts

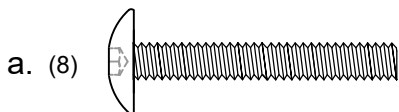

a. (8)

#6 x 1" Wood Screw



b. (14)

1/4" Flat Washer

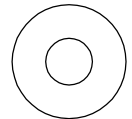

c. (8)

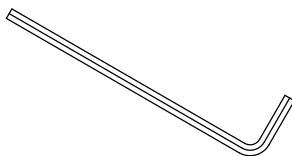

d. (1) Allen Wrench 1/4"



ID-TAG w/ HDW
(1 REQ)

STEP 1

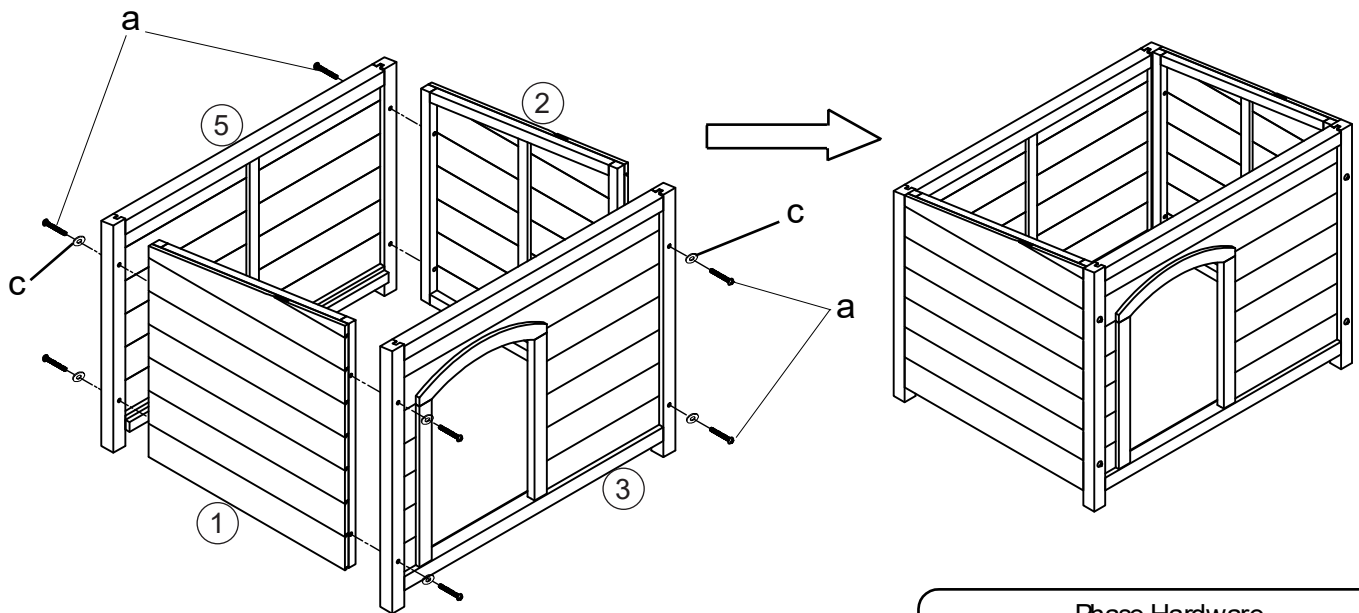

Phase Hardware

1/4"X2 1/4" Socket Head Bolts 1/4" Flat Washer

a. (8) 

c. (8) 

STEP 2

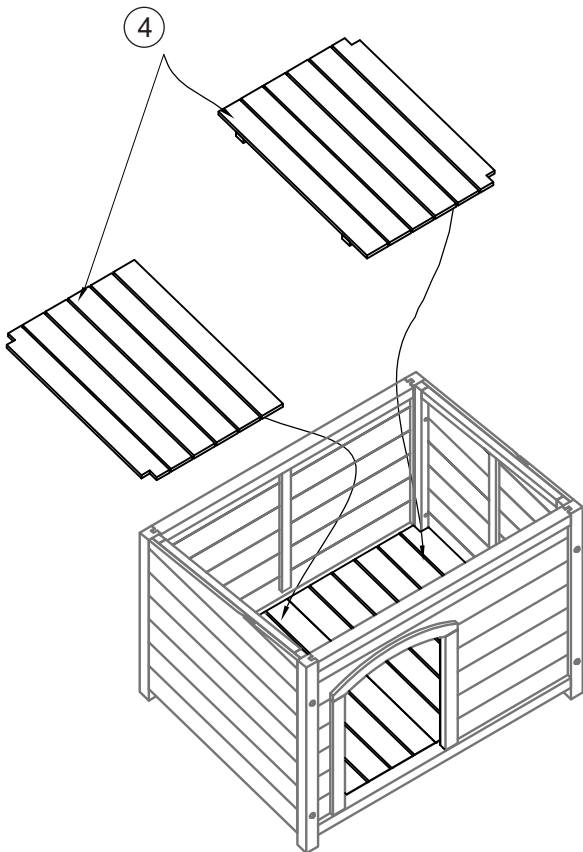

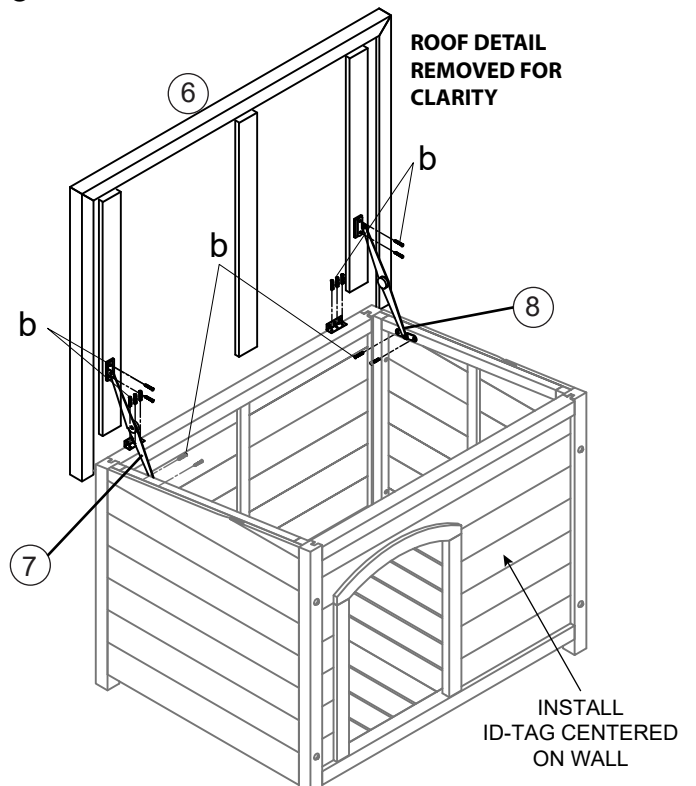

STEP 3



Phase Hardware

#6 x 1" Wood Screw

b. (14) 

 ID-TAG
w/ HARDWARE
(1) REQ.

LIMITED WARRANTY

Creative Cedar Design (CCD) offers many fun, interactive, and safe play sets. We only guarantee the original purchaser that this product is free of defects for 30 days from the date of purchase. The product registration card, along with a dated purchase receipt, must be returned to CCD within 30 days.

Within a 30 day period, CCD will repair or replace, at our option, defective merchandise free of charge, provided that the defective part is a manufacturer's defect and not seasonal check. CCD requires photographs of the part in question. The customer service center must be contacted for authorization for all warranty related service. After the 30 day period, the customer is responsible for all shipping and handling charges, even if the warranty claim has been approved. Depending on the size of the part, quantity of the order, availability of part at the time, the claim can take between 1-3 weeks.

Under this warranty there will be a replacement for the defective component of the play set. A 1-year Warranty is available on all components with a manufacturer's defect. A 10-year Limited Warranty is available on wood parts (4x6 and 4x4) against wood rotting and termite damage. This guarantee is effective only if the product is used for the purpose for which it was designed, maintained with accordance to the instructions, and installed at a residential, single family dwelling.

The warranty does not cover, (a) products which have been damaged by acts of God, negligence, misuse, or accident, or which have been modified or repaired by unauthorized persons; (b) the cost of labor; (c) the cost of shipping the product, any part, or any replacement product or part; (d) damage caused by the addition of any accessories not sold by CCD.

Cosmetic defects that do not affect the structural integrity of the product, or natural defects of wood such as warping, checking or any other physical properties of wood that do not present a safety hazard, are not covered by this warranty. Defects that develop because the product is exposed to extreme climate conditions are not covered by this warranty. Defects that develop as a result of faulty or improper installation of the product are also not covered by this warranty.

For warranty service or replacement part information, please visit our website at www.creativecedardesigns.com and submit a request. If you have any additional questions, please call 1-888-363-4967.

Replacement parts are available for purchase after the warranty expires. Please contact us by email at custservice@creativecedardesigns.com for details.

Warranty: 1 Year for all Components	
Days from Date of Purchase	Cost to Customer
With in 30 days	No Cost
After 30 days , but within 1 year	Shipping and Handling (S&H)

Warranty: 10 Year Pro Rated for Wood Parts (4x4 and 4x6 ONLY against wood rot and termite damage)	
Years from Date of Purchase	Cost to Customer
0-1 (after first 30 days through Year 1)	Cost of S&H and 0% on part
2-3	Cost of S&H and 20% on part
4-5	Cost of S&H and 40% on part
6-7	Cost of S&H and 60% on part
8-9	Cost of S&H and 80% on part
Over 10	Cost of S&H and 100% on part

Warranty claim procedure

If you are confident that your play system has been installed and maintained properly, and you have a warranty claim, proceed with the following steps:

1. We will need copy of your proof of purchase (Vendor sales receipt only.)
2. We require a brief written description of the warranty issue.
3. Photos of warranted parts and of the entire play system.

If **any** of the above steps are not completed, there may be delays in the completion of your claim, or possibly warranty cancellation.

Mail information to:

Creative Cedar Designs
2700 Riverside Dr
Chattanooga, TN 37406

Or email at

custservice@creativecedardesigns.com

Our customer service department will review the claim and make contact with the customer by mail or by phone.

1-888-363-4967