

Assembly Instructions

MODEL# B9005DC

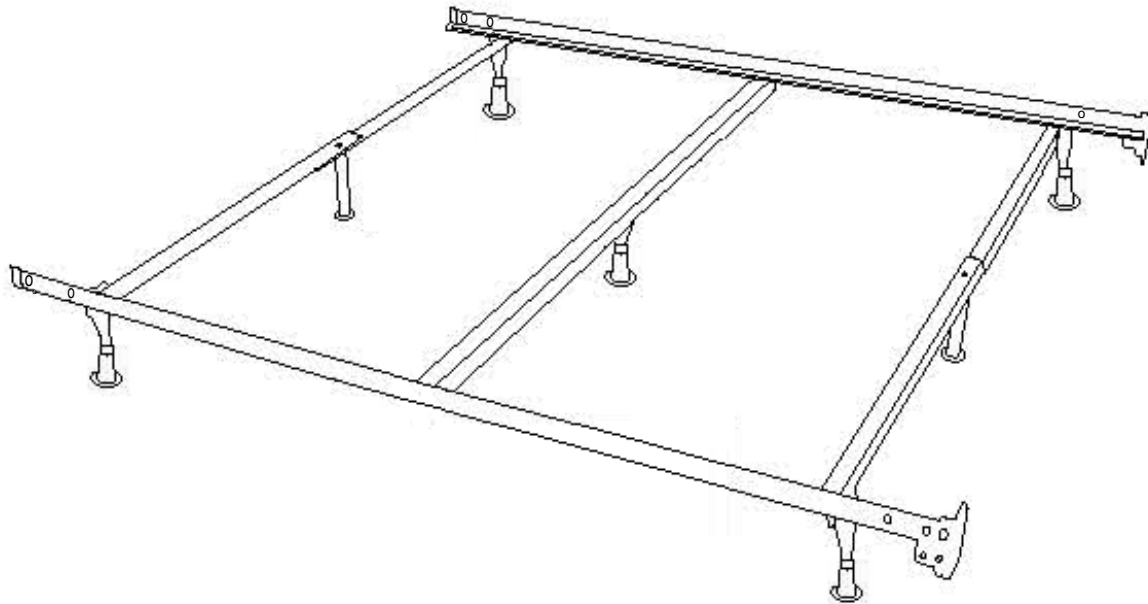

Important Notice:

This item designed to universal for TWIN/FULL/QUEEN three size,
Please follow the steps to get your desired size; Make sure the
Center Support Bar is correctly assembled see Details in **Step 3**

Parts List

Parts ID	Image	Description	Qty
A		Side rail with cross bar (left)	1
B		Side rail with cross bar (right)	1
C		Center Support Leg	2
D		Plastic Corner Pad	2
E		Glide	5
F		Center Support Bar	1

Hardware Parts

Parts ID	Image	Description	Qty
1		Bolt 15mm	2
2		Bolt 25mm	2
3		Washers	2
4		Nut	2
5		Wrench	1
6		Allen Key	1

MODEL#: B9005DC

TWIN/FULL/QUEEN ASSEMBLY

Step 1 Swing out cross arms to 90 degrees.

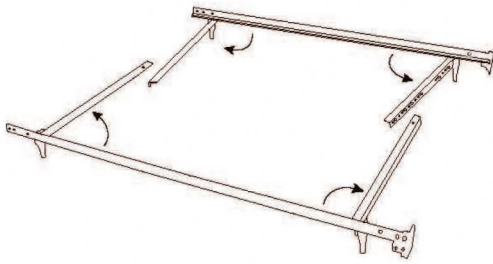

Step 2 Place rivets of the cross arms into appropriate key holes then slide to lock as shown in Figure 1.

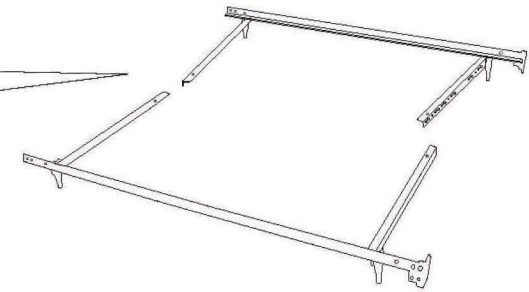
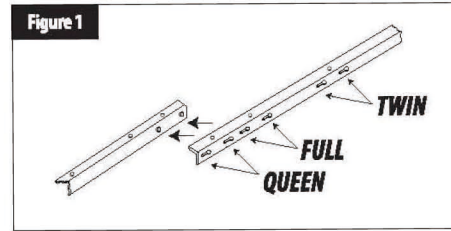

Step 3 Attach center support with bolt (2), nut (4) and washer (3) as shown in Figure 2 (Side-to-side for queen size and diagonally for full size and twin size). Use tool 5&6.

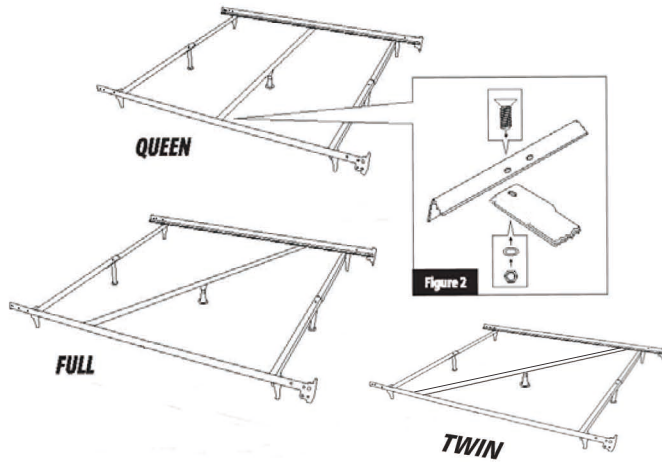

Step 4 Install glide as shown in Figures 3 and 4.

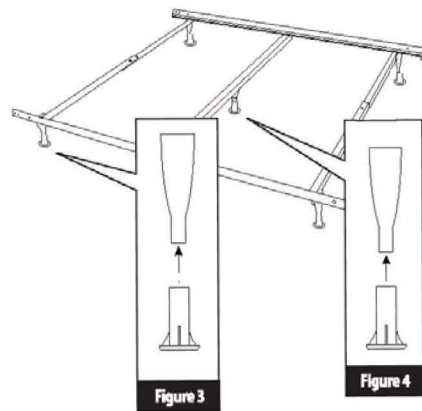

Step 5 Place support legs under holes that align on center of cross arms. Screw in as shown in Figure 5. Use bolts NO1.

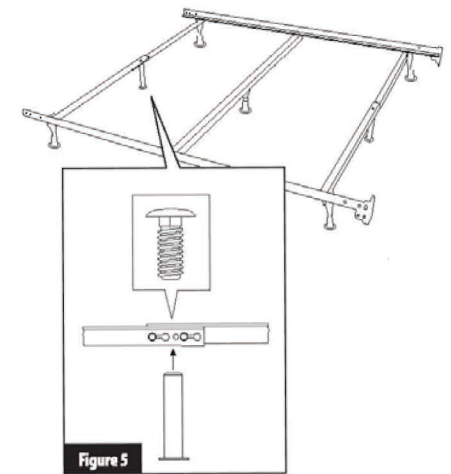

Step 6 Put the plastic corner pad to the end of the side rails shown in figure 6.

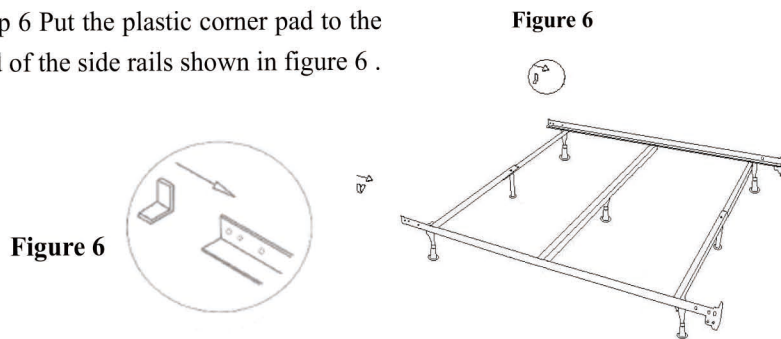

Finish

Important Warnings:

Always use the center legs to Increase the weight capacity for the whole set, when moving the bed, please make sure the center support legs are not bent.

