

Zone Sentry® Series

The Taco Zone Sentry® Zone Valve enhances the overall performance of any zone valve system. The unique patented technology in the Zone Sentry utilizes a microcircuit based logic to control a gear driven electronic actuator which drives a ball valve based body design. All this adds up to a zone valve that leads the industry in energy efficiency, flow capacity (Cv), shutoff pressure rating, ease of installation, diagnostic capability and the number of valves (12) that can be use on a standard 40VA transformer.



Zone Sentry® Series

Zone Sentry®



Application:

Taco Zone Sentry® zone valves provide on-off, normally open or normally closed control in closed hydronic systems. (See Geo-Sentry for open system application) The valves can be used in a wide variety of heating and condensing cooling applications, primarily designed for use with baseboard, fan coils, radiators, convectors, air handlers, heat pumps and radiant applications.

For Indoor Use Only

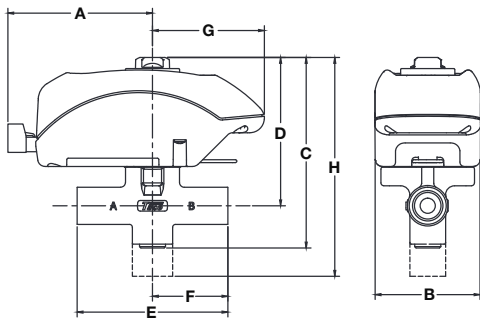

Zone Sentry Dimensions: (FOR REFERENCE PURPOSES)

Valve Size	A		B		C		D		E (Sweat/Press)		E (Threaded)		F		G		H (3-way)	
	in.	mm	in.	mm	in.	mm	in.	mm	in.	mm	in.	mm	in.	mm	in.	mm	in.	mm
1/2"	3"	76.2	2.375"	60.3	4.125"	104.7	3.06"	77.72	3.125"	79.3	4.750"	120.6	1.562"	39.7	2.312"	58.7	5.06"	128.5
3/4"	3"	76.2	2.375"	60.3	4.125"	104.7	3.12"	79.25	3.125"	79.3	3.312"	84.1	1.562"	39.7	2.312"	58.7	5.37"	136.4
1"	3"	76.2	2.375"	60.3	4.125"	104.7	3.12"	79.25	3.875"	98.4	3.875"	98.4	1.875"	47.6	2.312"	58.7	5.50"	139.7
Inverted Flare 3/4" sweat fitting	3"	76.2	2.375"	60.3	3.5"	99.1	3.06"	77.72	7.375"*	187.33	3.5***	88.9	1.75"	44.5	3.312"	58.7	N/A	N/A
1/2", 3/4", 1" Press Connect	3"	76.2	2.375"	60.3	4.125"	104.7	3.12"	79.25	6.2***	157	N/A	N/A	3.1	78.5	2.312"	58.7	N/A	N/A

* Includes inverted flare fitting ** Less fittings *** Press Dimension

NPT Models	2-Way	Sweat Models	NPT Models	3-Way	Sweat Models	Press Connect	Size	Inverted Flare	Valve Size	2-Way Cv (Kv) / Ft of Pipe Equiv. †	Close-Off Pressure (kPa)	3-Way Cv (Kv) / Ft of Pipe Equiv. †
Z050T2	1/2" 2-way	Z050C2	Z050T3	1/2" 3-way	Z050C3	Z050P2	1/2"	---	1/2"	4.9 (4.3) / 9.5	0-125 psi (0-862 kPa)	1.5 (1.3) / 111
									1/2" Press	3.4 (2.9) / 19.6		
Z075T2	3/4" 2 way	Z075C2	Z075T3	3/4" 3-way	Z075C3	Z075P2	3/4"	Z075F2	3/4"	10.3 (8.9) / 8.4	0-125 psi (0-862 kPa)	3.3 (2.8) / 82
									3/4" Press	9.5 (8.1) / 9.9		
Z100T2	1" 2-way	Z100C2	Z100T3	1" 3-way	Z100C3	Z100P2	1"	---	1"	8.9 (7.7) / 47.4	0-125 psi (0-862 kPa)	3.0 (2.6) / 411
									1" Press	7.5 (6.4) / 66.8		
									Inverted Flare 3/4" SWT	3.5 (3.0) / 72.9	0-125 psi (0-862 kPa)	N/A

All models shown are normally closed. Consult factory for additional model numbers

† At 4' per second (Max. recommended residential flow rate)

Product Specifications

Max. Operating Pressure.....	300 PSI (2100 kPa)
Max. Shutoff Pressure.....	125 PSI (875 kPa)
Max. Ambient Temp.	135°F
Fluid Temp. Range	20-220°F (-7°-104°C)
Service	Water or Water/Glycol up to 50% Glycol Close Systems (Open system — option available)
Ball Rotation Speed.....	(90° turn), Approx. 5 seconds (After charge time)
Electrical Rating	24 VAC, 60Hz, 0.48 Amps
Power Consumption	11.4 W, 0.48 Amps (Charging)
Power Consumption	1.44W, 0.06 Amps (Power On)
Heat Anticipator Setting.....	0.5 Amps
End Switch Rating.....	1 Amp @ 24 VAC

Materials of Construction

Actuator:

Body.....	High Performance Engineered Polymer
Gears.....	High Performance Internally Lubricated Engineered Polymer

Valve:

Body.....	Forged Brass
Stem.....	Brass
Press Ring.....	Brass
Ball.....	Brass (Chrome Plated)
Seat.....	Modified Teflon®
O-Rings.....	EPDM

Zone Sentry® Series

Geo-Sentry®



Application:

The Geo-Sentry® zone valve provides on/off, normally open or normally closed control and is especially suited for use in either open or closed loop geothermal systems with water source heat pumps.

For Indoor Use Only

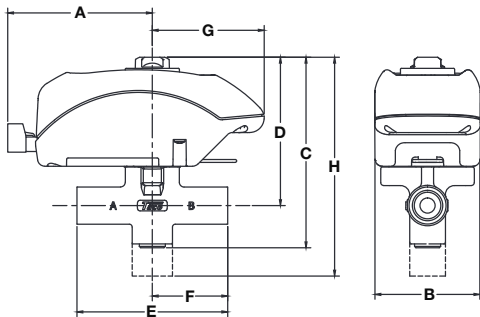

NOTE: Geo-Sentry is also available with Multi-Volt actuator

Product Specifications

Max. Operating Pressure.....	300 PSI (2100 kPa)
Max. Shutoff Pressure.....	125 PSI (875 kPa)
Max. Ambient Temp.	24V 135°F / Multi-Volt 150°F
Fluid Temp. Range	20-220°F (-7°-104°C)
Service.....	Open and closed systems
Fluids.....	Water Up to25% Ethanol Up to25% Methanol Up to50% Glycol Steam 15 psi max.
Ball Rotation Speed.....	(90° turn), Approx. 5 seconds (After charge time)
Electrical Rating.....	24 VAC, 60Hz, 0.48 Amps
Power Consumption	11.4 W, 0.48 Amps (Charging)
Power Consumption	1.44W, 0.06 Amps (Power On)
Heat Anticipator Setting.....	0.5 Amps
End Switch Rating.....	1 Amp @ 24 VAC

Materials of Construction

Actuator:	
Body.....	High Performance Engineered Polymer
Gears.....	High Performance Internally Lubricated Engineered Polymer
Valve:	
Body.....	Forged Brass
Stem.....	Brass
Press Ring	Brass
Ball.....	Brass (Chrome Plated)
Seat.....	Modified Teflon®
O-Rings	EPDM

Geo-Sentry Dimensions: (FOR REFERENCE PURPOSES)

Valve Size	A		B		C		D		E (Sweat)		E (Threaded)		F		G		H (3-way)	
	in.	mm	in.	mm	in.	mm	in.	mm	in.	mm	in.	mm	in.	mm	in.	mm	in.	mm
1/2"	3"	76.2	2-3/8"	60.3	4-1/8"	104.7	3-1/16"	77.8	3-1/8"	79.3	3-3/4"	95.3	1-9/16"	39.7	2-5/16"	58.7	5-1/16"	128.5
3/4"	3"	76.2	2-3/8"	60.3	4-1/8"	104.7	3-1/8"	79.3	3-1/8"	79.3	3-5/16"	84.1	1-9/16"	39.7	2-5/16"	58.7	5-3/8"	136.4
1"	3"	76.2	2-3/8"	60.3	4-1/8"	104.7	3-1/8"	79.3	3-7/8"	98.4	3-7/8"	98.4	1-7/8"	47.6	2-5/16"	58.7	5-1/2"	139.7

NPT Models Normally Closed	2-Way	NPT Models Normally Closed	3-Way	Valve Size	2-Way Cv (Kv) / Ft of Pipe Equiv. **	Close-Off Pressure (kPa)	3-Way Cv (Kv) / Ft of Pipe Equiv. **
V050T2G2ZA024Q4A1	1/2" 2-way	V050T3G1ZA024Q4A1	1/2" 3-way	1/2"	4.9 (4.3) / 9.5	0-125 psi (0-862 kPa)	1.5 (1.3) / 111
V075T2G2ZA024Q4A1	3/4" 2 way	V075T3G1ZA024Q4A1	3/4" 3-way	3/4"	10.3 (8.9) / 8.4	0-125 psi (0-862 kPa)	3.3 (2.8) / 82
V100T2G2ZA024Q4A1	1" 2-way	V100T3G1ZA024Q4A1	1" 3-way	1"	8.9 (7.7) / 47.4	0-125 psi (0-862 kPa)	3.0 (2.6) / 411

Consult factory for additional model numbers

**At 4' per second (Max. recommended residential flow rate).

Zone Sentry® Series

Potable Water Zone Sentry® ($\leq 0.25\%$ Lead)



Application:

The Taco Potable Water Zone Sentry zone valve is available in a 2-way sweat configuration with either a normally open or normally closed actuator. Some typical installations would include a combination domestic water and hydronic heating system, culinary installation or water shut off to a potable system.

For Indoor Use Only

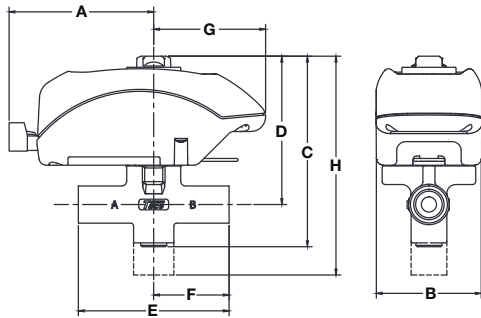

Product Specifications

Max. Operating Pressure.....	300 PSI (2100 kPa)
Max. Shutoff Pressure.....	125 PSI (875 kPa)
Fluid Temp. Range	33-220°F (1°-104°C)
Service.....	Potable Water
Ball Rotation Speed.....	(90° turn), Approx. 5 seconds (After charge time)
Electrical Rating.....	24 VAC, 60Hz, 0.48 Amps
Power Consumption	11.4 W, 0.48 Amps (Charging)
Power Consumption	1.44W, 0.06 Amps (Power On)
End Switch Rating.....	1 Amp @ 24 VAC

Materials of Construction

Actuator:	
Body.....	High Performance Engineered Polymer
Gears.....	High Performance Internally Lubricated Engineered Polymer
Valve:	
Body.....	Forged Brass
Stem.....	Brass
Press Ring	Brass
Ball.....	Brass (Chrome Plated)
Seat.....	Modified Teflon®
O-Rings	Viton

Potable Water Zone Sentry® Dimensions: (FOR REFERENCE PURPOSES)

Part Number	Valve Size	Valve Type	A		B		C		D		E		F		G	
			in.	mm	in.	mm	in.	mm	in.	mm	in.	mm	in.	mm	in.	mm
V050C2D2ZA024Q4A1 (Normally Closed)	1/2"	2-way Sweat	3"	76.2	2.375"	60.3	4.125"	104.7	3.06"	77.72	3.125"	79.3	1.562"	39.7	2.312"	58.7
V075C2D2ZA024Q4A1 (Normally Closed)	3/4"	2-way Sweat	3"	76.2	2.375"	60.3	4.125"	104.7	3.12"	79.25	3.125"	79.3	1.562"	39.7	2.312"	58.7
V050C2D2ZB024Q4A1 (Normally Open)	1/2"	2-way Sweat	3"	76.2	2.375"	60.3	4.125"	104.7	3.06"	77.72	3.125"	79.3	1.562"	39.7	2.312"	58.7
V075C2D2ZB024Q4A1 (Normally Open)	3/4"	2-way Sweat	3"	76.2	2.375"	60.3	4.125"	104.7	3.12"	79.25	3.125"	79.3	1.562"	39.7	2.312"	58.7

Valve Size	Cv (Kv) / Ft. of Pipe Equiv.**	Close-Off Pressure (kPa)
1/2"	4.9 (4.3) / 9.5	0-125 psi (0-862 kPa)
3/4"	10.3 (8.9) / 8.4	0-125 psi (0-862 kPa)

**At 4' per second (Max. recommended residential flow rate)

Zone Sentry® Series

Multi-Volt Zone Sentry®

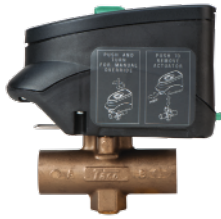

Application:

One valve takes the place of many. The Multi-Volt Zone Sentry will accept input voltages between 120 and 277VAC 50/60HZ. The Multi-Volt Zone Sentry zone valve is designed for use in hydronic HVAC systems, primarily in fan coils and air handlers or other HVAC systems where a quality line voltage zone valve is required. The Multi-Volt Zone Sentry can be installed in both heating and cooling applications and is available in a normally closed or normally open configuration.

For Indoor Use Only

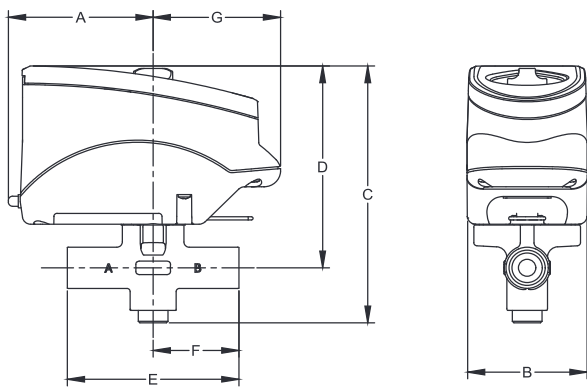

Product Specifications

Max. Operating Pressure.....	300 PSI (2100 kPa)
Max. Shutoff Pressure.....	125 PSI (875 kPa)
Max. Ambient Temp.	150°F
Fluid Temp. Range	20-220°F (-7°-104°C)
Service	Closed systems Optional open system configuration available Water/Water and glycol up to 50%
Seat Leakage	Drop-Tight Close-Off
Electrical Rating.....	120 VAC to 277VAC, 1Ph, 50/60Hz
Power Consumption	4 Watts (Charging)
Power Consumption	1.5 Watts (Power On)
Max. Duty Cycle.....	1 Cycle/Minute

Materials of Construction

Actuator:	
Body.....	High Performance Engineered Polymer
Gears.....	High Performance Internally Lubricated Engineered Polymer
Valve:	
Body.....	Forged Brass
Stem.....	Brass
Press Ring	Brass
Ball.....	Brass (Chrome Plated)
Seat.....	Modified Teflon®
O-Rings.....	EPDM

NOTE: The Multi-Volt actuator is available on all versions of Zone Sentry



Multi-Volt Zone Sentry® Dimensions: (FOR REFERENCE PURPOSES)

Valve Size	A		B		C		D		E (Sweat)		E (Threaded)		F		G	
	in.	mm	in.	mm	in.	mm	in.	mm	in.	mm	in.	mm	in.	mm	in.	mm
1/2"	2-5/8"	66.6	2-3/8"	60.3	4-7/8"	123.8	3-3/4"	95.3	3-1/8"	79.4	3-3/4"	95.3	1-9/16"	39.7	2-5/16"	58.7
3/4"	2-5/8"	66.6	2-3/8"	60.3	5"	127	3-7/8"	98.4	3-1/8"	79.4	3-5/16"	84.1	1-9/16"	39.7	2-5/16"	58.7
1"	2-5/8"	66.6	2-3/8"	60.3	5"	127	3-7/8"	98.4	3-7/8"	98.4	3-7/8"	98.4	1-7/8"	47.6	2-5/16"	58.7

NPT Models Normally Closed	2-Way	Sweat Models Normally Closed	NPT Models	3-Way	Sweat Models	Valve Size	2-Way Cv (Kv) / Ft of Pipe Equiv. *	Close-Off Pressure (kPa)	3-Way Cv (Kv) / Ft of Pipe Equiv. *
V050T2A2ZALNVE2A1	1/2" 2-way	V050C2A2ZALNVE2A1	V050T3A1ZALNVE2A1	1/2" 3-way	V050C3A1ZALNVE2A1	1/2"	4.9 (4.3) / 9.5	0-125 psi (0-862 kPa)	1.5 (1.3) / 111
V075T2A2ZALNVE2A1	3/4" 2 way	V075C2A2ZALNVE2A1	V075T3A1ZALNVE2A1	3/4" 3-way	V075C3A1ZALNVE2A1	3/4"	10.3 (8.9) / 8.4	0-125 psi (0-862 kPa)	3.3 (2.8) / 82
V100T2A2ZALNVE2A1	1" 2-way	V100C2A2ZALNVE2A1	V100T3A1ZALNVE2A1	1" 3-way	V100C3A1ZALNVE2A1	1"	8.9 (7.7) / 47.4	0-125 psi (0-862 kPa)	3.0 (2.6) / 411

Consult factory for additional model numbers
 *At 4' per second (Max. recommended residential flow rate).

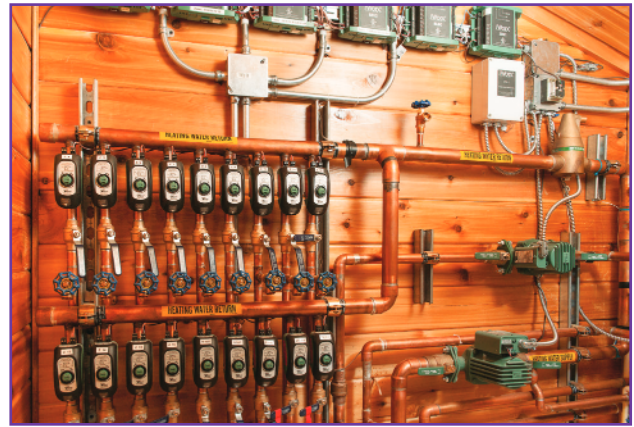

The Taco Zone Sentry® Zone Valve leads the industry in energy efficiency, flow capacity (C_v), shutoff pressure rating, ease of installation, diagnostic capability and the number of valves (12) that can be use on a standard 40VA transformer. Taco Zone Sentry zone valves are available variety of configurations.

Ease of Installation / Operation:

The Zone Sentry is the most technologically advanced zone valve ever made. It's also simple to install and operate. The valve can be installed in any direction, in any orientation except for chilled water installations (see Figure B). Furthermore, the actuator can be mounted to the valve body in either direction (see Figure A). Before installing the valve body please note removal clearances (see Figure C). Snap-in quick connects on the back of the valve make for a simple, secure and fast wiring hook-up. A green LED light shows full functionality of the valve's operation and thermostat status. Under a no power situation the manual override button located on the top of the valve allows the ball to be rotated up to 90° and is also marked with a slot to indicate the position of the valve.

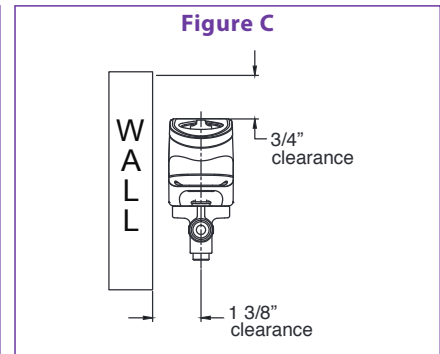
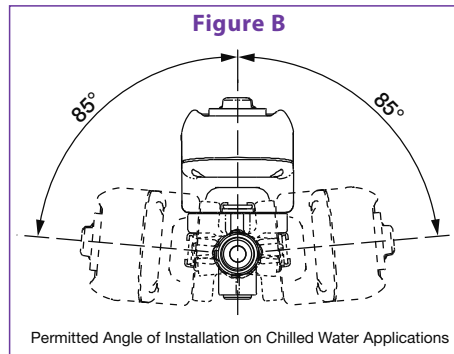
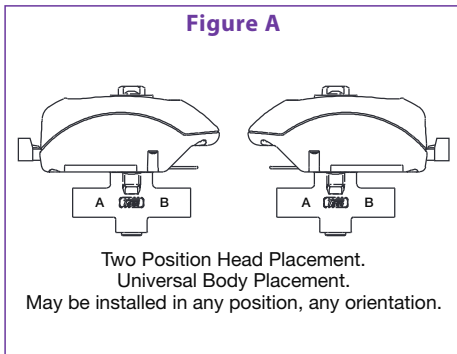

Taco Inc., 1160 Cranston Street, Cranston, RI 02920 / (401) 942-8000 / Fax (401) 942-2360
Taco (Canada) Ltd., 8450 Lawson Road, Unit #3, Milton, Ontario L9T 0J8 / (905) 564-9422 / Fax (905) 564-9436