

# COMMERCIAL PATIO HEATER



## FIRESENSE 48,000 BTU COMMERCIAL PATIO HEATER



**WARNING!**  
For Outdoor Use Only.



**WARNING!**  
Improper installation, adjustment, alteration, service or maintenance can cause property damage, injury or death. Read the installation, operation and maintenance instructions thoroughly before installing or servicing this equipment.

Save these instructions for future reference. Please ensure the owner of the heater retains the manual for future reference.



ANS Z83.26-2007 / CSA 2.37-2007  
Gas-Fired Infrared Patio Heater



**ITEM # 61541**

**US** Portable Infra-Red open-air heater  
for non residential space heating  
Assembly and usage instructions

**Questions, problems, missing parts?**

Before returning to your retailer, call our customer service hotline  
at **1-866-985-7877**, 9 a.m. – 6 p.m., EST, Monday – Friday  
or email at [cservice@welltraveled.net](mailto:cservice@welltraveled.net).





**WARNING  
FOR YOUR SAFETY**

If you smell gas:

1. Shut off the gas to the appliance.
2. Extinguish any open flame.
3. If odor continues, keep away from the appliance and immediately call your gas supplier or fire department.



**WARNING**

**California Proposition 65:**  
Chemicals known to the state of California to cause cancer, birth defects, or other reproductive harm are created by the combustion of propane.



**WARNING  
FOR YOUR SAFETY**

1. Gas leaks may cause a fire or explosion which can cause serious bodily injury, death or damage to property.
2. You must follow all leak checking procedures as outlined in step 8 before operating this unit.
3. Never use an open flame to check for leaks.



**WARNING**

- Purchaser assumes all risk in the assembly and operation of this unit. Failure to follow this manual's **WARNINGS** and instructions can result in severe personal injury, death or property damage.
- Do not use in an explosive atmosphere. Keep heater away from areas where flammable liquids, gasoline, vapours, or explosives are stored or used.



**WARNING  
FOR YOUR SAFETY**

Do not store or use gasoline or other flammable vapours and liquids in the vicinity of this or any other appliance.  
An LP-cylinder not connected for use shall not be stored in the vicinity of this or any other appliance.



**WARNING**

Beware of sharp edges, ensure gloves are worn on assembly.

<b>TABLE OF CONTENTS</b>		<b>Page</b>
1	SAFETY FIRST	4 - 5
2	ASSEMBLY INSTRUCTIONS in 11 steps	6 - 13
3	OPERATION	14
3.1	BEFORE TURNING GAS SUPPLY "ON"	14
3.2	BEFORE LIGHTING	15
3.3	LIGHTING	16
3.4	WHEN HEATER IS "ON"	16
3.5	RE-LIGHTING	16
3.6	SHUTDOWN	16
4	OPERATION CHECKLIST	17
5	CLEANING & MAINTENANCE	18
6	STORAGE	18
7	SPECIFICATIONS	19
8	SERVICE ADDRESS	19
9	WARRANTY	20

The use and installation of this product must conform to local codes. In absence of local codes, use the National Fuel and Gas Code, ANSI Z223, 1/NFPA 54, Storage and Handling of Liquid Petroleum Gases, ANSI/NFPA 58 or CSA B149.1, Natural Gas and Propane Installation Code.

The installation must conform with local building codes or, in the absence of local codes, with the current CAN 1-B149 installation codes.



**THE CONVERSION SHALL BE CARRIED OUT BY A MANUFACTURE'S AUTHORISED REPRESENTATIVE, IN ACCORDANCE WITH THE REQUIREMENTS OF THE MANUFACTURER, PROVINCAL OR TERRITORIAL AUTHORITIES HAVING JURISDICTION AND IN ACCORDANCE WITH THE REQUIREMENTS OF THE CAN/CGA-B149.1 OR CAN/CGA-B149.2 INSTALLATION CODES**



## 1. SAFETY FIRST!

Read and become familiar with this entire manual especially the following precautions. If you are unsure of anything in these instructions, STOP and contact for assistance.

### Caution:

**This application is for outdoor use only (outside any enclosure).**

**Always make sure there is fresh air ventilation.**

- Always maintain at least 36" clearance (top) and 24" clearance (side) from combustible materials.
- Always place heater on a hard and level surface and mounted.
- Do not use if the wind velocity is greater than 10 miles per hour.
- Unit will operate at reduced efficiency below 40°F (5°C).
- Keep sprinklers and other water sources away from burner and controls.



- **Always use extreme caution when near heater. Alert both children and adults to the hazards of high temperatures, especially to avoid burns or clothing catching fire.**

- **Young children and pets should be carefully supervised when they are in the area of the heater.**

- **Do not hang clothing or other flammable materials either on or near the heater.**

- **Any guard or other protective device removed for servicing the heater must be replaced prior to operating the heater.**

- Certain materials or items, when stored under the heater, will be subjected to radiant heat and could be seriously damaged.

- Do not alter heater in any manner.

- The pressure regulator and hose assembly supplied with the appliance must be used and replacements must be those specified by the manufacturer. If regulator becomes damaged, use only a factory-supplied replacement.

- Inspect heater before each use. If a damaged part is detected, do not operate until an original equipment replacement part has been properly installed. Use of unauthorized parts will void warranty and create an unsafe condition.

**Please call 847 850 5335 for help!**

- Prior to operating the heater, replace any guards or protective devices removed for servicing.

- During operation, do not touch the burner assembly. The surface of the heater's emitter can reach temperatures approaching 1600°F

- After shutdown, do not touch the burner assembly until the heater has cooled (approximately 45 minutes after use).

### **Notice:**

This product should not be used with any fuel other than liquid propane.

Use of other fuels will detract from the heaters performance and will void your warranty.

### **The used LP-gas cylinder must be:**

- Constructed and marked in accordance with the Specifications for LP-gas cylinders of the U.S. Department of Transportation (DOT); or the Standard for Cylinders, Spheres and Tubes for Transportation of Dangerous Goods and Commission, CAN/CSA-B339, as applicable;
- Provided with a listed overfilling prevention device; and
- Provided with a cylinder connection device compatible with the connection for the appliance.

Storage of an appliance indoors is permissible only if the cylinder is disconnected and removed from the appliance. A cylinder must be stored outdoors in a well ventilated area out of the reach of children. A disconnected cylinder must have dust caps tightly installed and must not be stored in a building, garage or any other enclosed area.

Do not store a spare LP-gas cylinder under or near this appliance. Never fill the cylinder beyond 80 percent full. If the information above is not followed exactly, a fire causing death or serious injury may occur.

**Caution:**

**Liquid propane (LP) gas is flammable and hazardous if handled improperly. Become aware of the characteristics before using any LP product.**

- LP Characteristics — Flammable, explosive under pressure, heavier than air - settles in pools in low areas.
- In its natural state, propane has no odor. For your safety, an odorant is added and has a bad smell.
- Contact with LP can cause freeze burns to skin.
- This heater is shipped from the factory for LP gas use only.
- Use only Department of Transportation (DOT) approved “20 lb.” LP gas tanks (Same as those commonly used on gas grills) with Acme / Type 1 / QCC safety valves. These valves can be quickly identified because they have external and internal threads.
- Never use an LP tank with a damaged body, valve, collar, or foot ring.
- Dented or rusted LP tanks may be hazardous and should be checked by your LP gas supplier.
- The tank supply system must be arranged for vapour withdrawal.
- The tank used must include a collar to protect the tank valve.
- When heater is not in use, turn LP tank OFF.
- Always perform a leak test on gas connections whenever a tank is connected. Never use a flame to test for leaks. Do not smoke while performing a leak test.



**Caution:**

**It is essential to keep the heater’s valve compartment, burners, and circulating air passages clean.**

- Spiders and insects can create a dangerous condition that may damage the heater or make it unsafe. Keep the burner area clean of all spiders, webs, or insects.
- Inspect the heater before each use.
- **Have heater inspected annually and repairs should be made by a qualified service person.**
- Check the heater immediately if any of the following conditions exist:
  - The smell of gas in conjunction with extreme yellow tipping of burner flames.
  - Heater does not reach the proper temperature.

**Note:**

At temperatures less than 40°F, heat output will be reduced.

- Heater’s glow is excessively uneven
- Burner makes popping noises during use.

**Note:**

A slight pop is normal when burner is extinguished.

- Carbon deposits may create a fire hazard. Keep dome and emitter clean at all times.
- Do not clean heater with combustible or corrosive cleaners. Use warm, soapy water.
- Do not paint the burner, the burner access panel or dome.

**FOR YOUR SAFETY  
BE AWARE OF SPIDERS**

Spiders or small insects can get into the burner tube or other openings of your heater and spin webs or build nests.

These obstructions can lead to gas flow problems. It is important to make frequent inspections of these areas and clean them when necessary.

Before operating your heater for the first time, be sure to check for obstructions that may have occurred during shipment.

US

## 2. ASSEMBLY INSTRUCTIONS

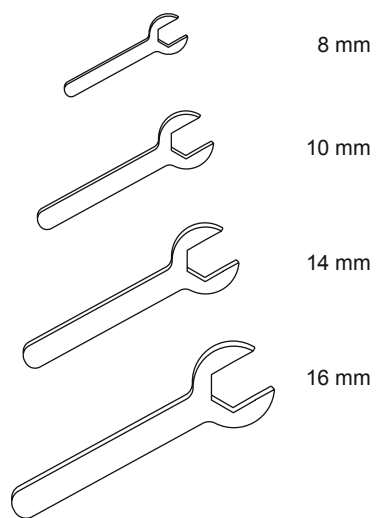
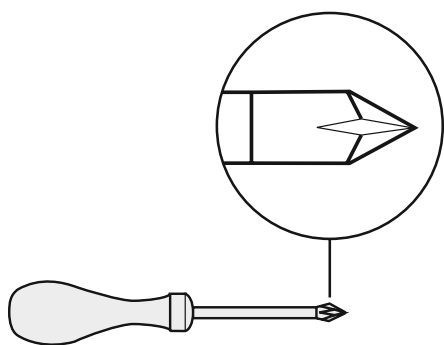
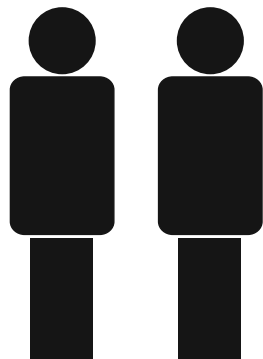

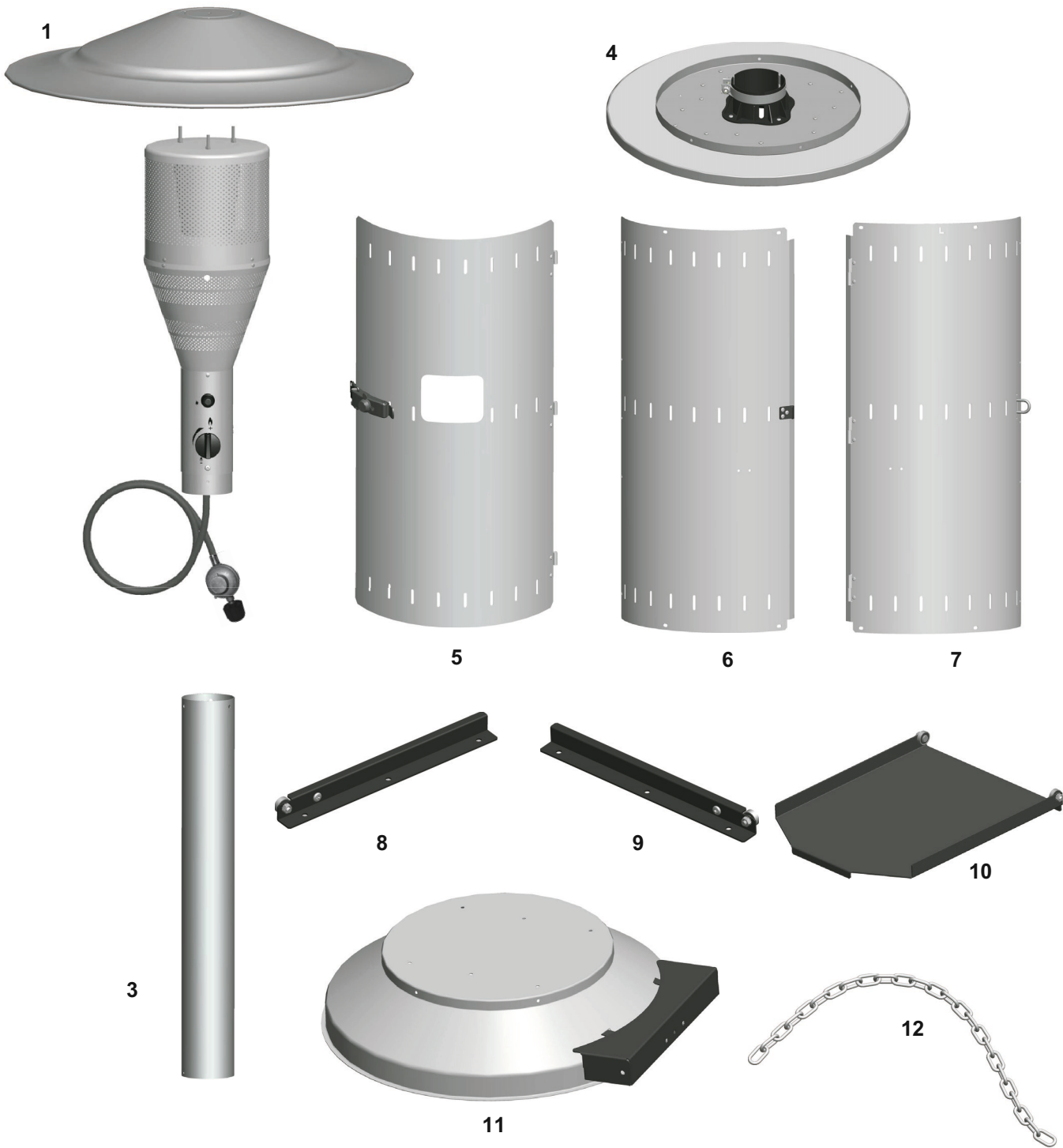

**13**  
13x



M5x12

**14**  
11x



M6x12

**15** Ø5,3 13x



**18** M6 11x



**16** M5 13x



**19** 320mm 1x

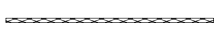

**17** Ø6.3 11x



**20** 400mm 1x

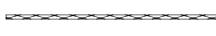

To avoid cuts, you have to wear safety gloves during installation.

Get help by a second person during the installation.



1

Remove the protective foil from all parts first!

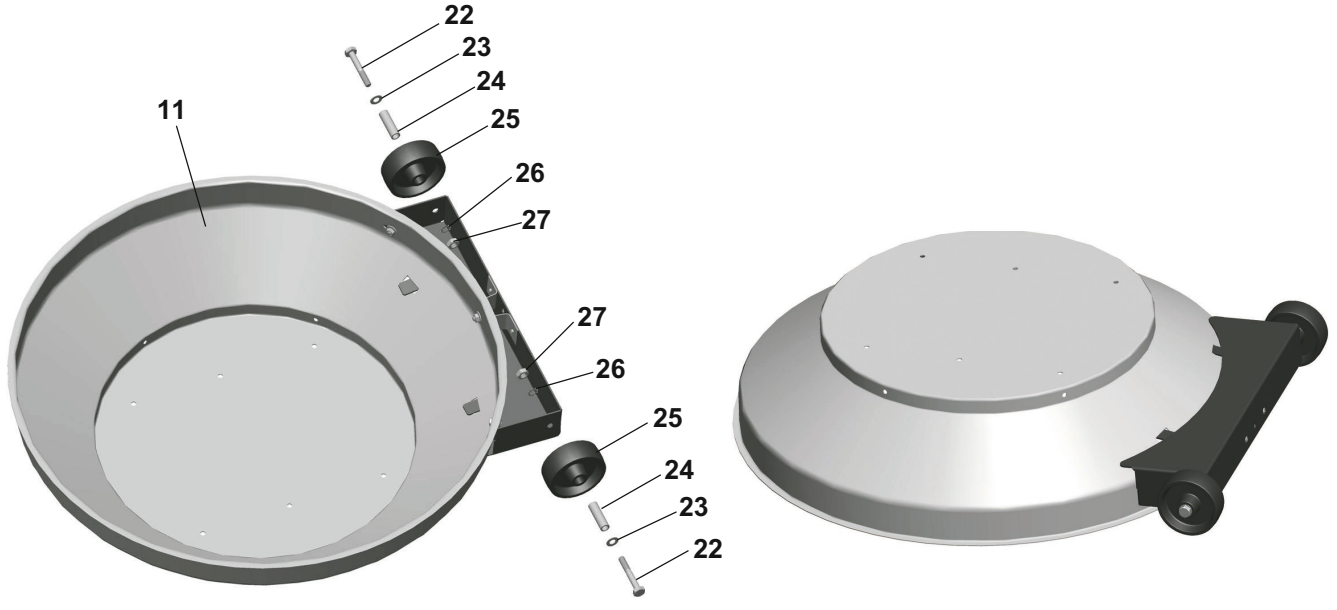

2

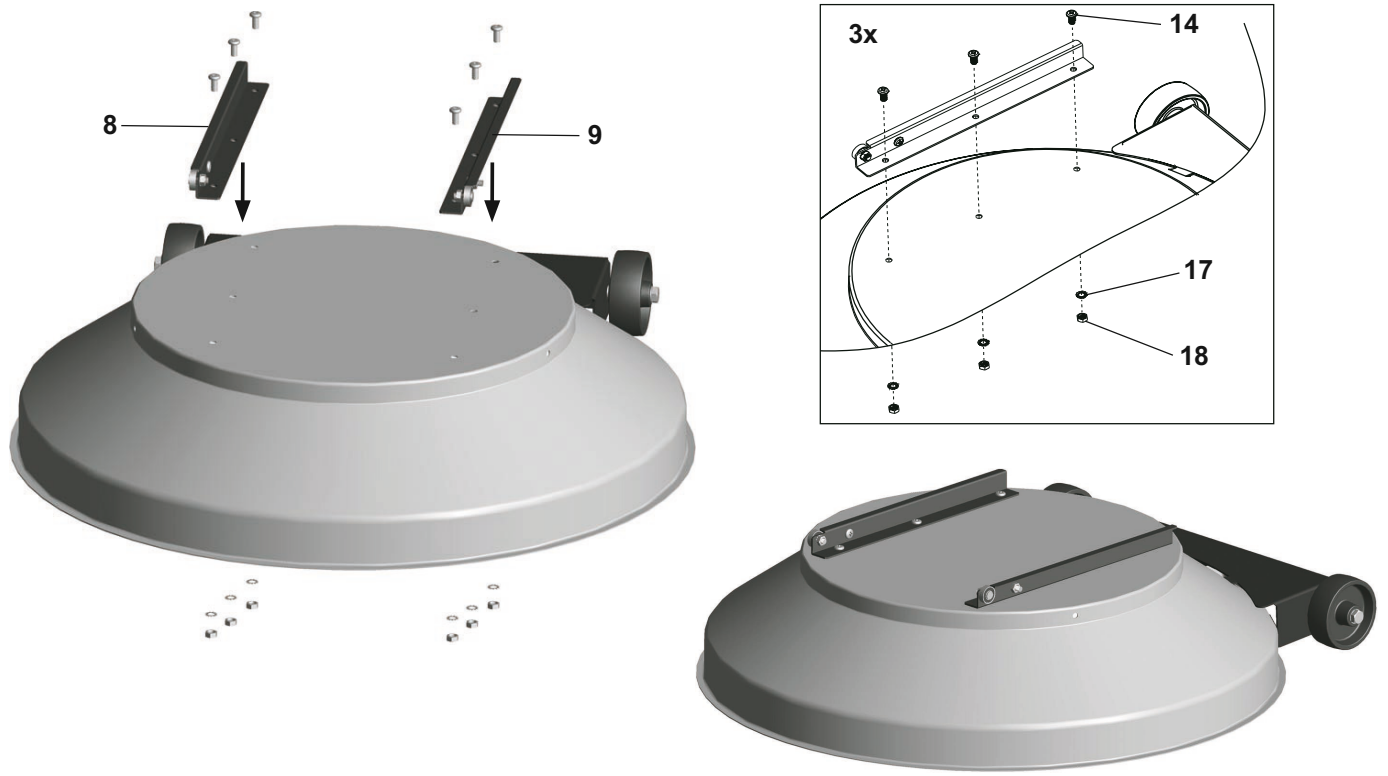

3

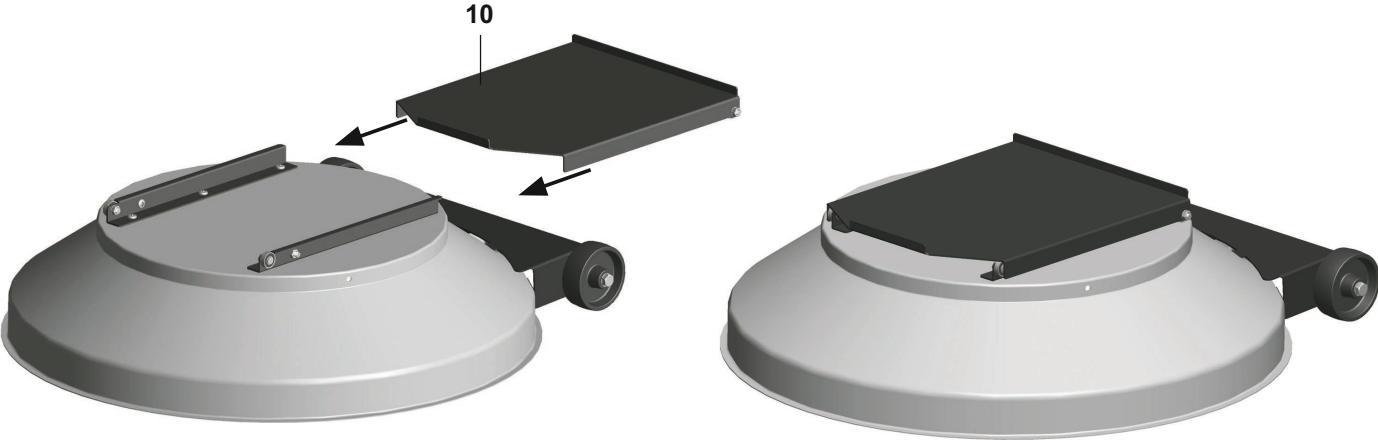

4

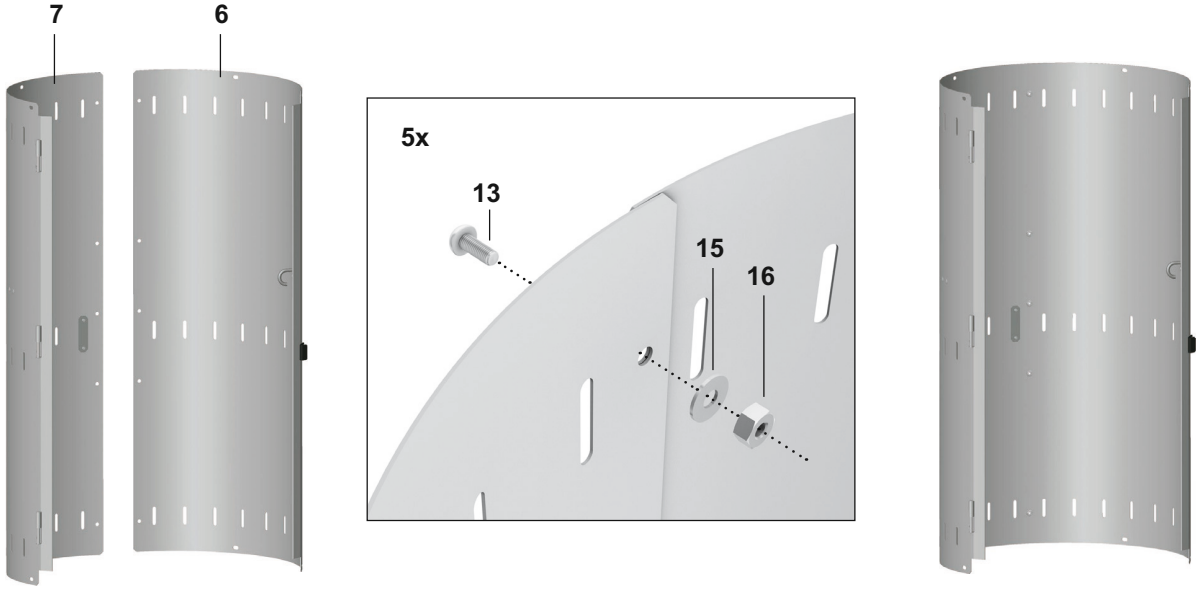

US

5

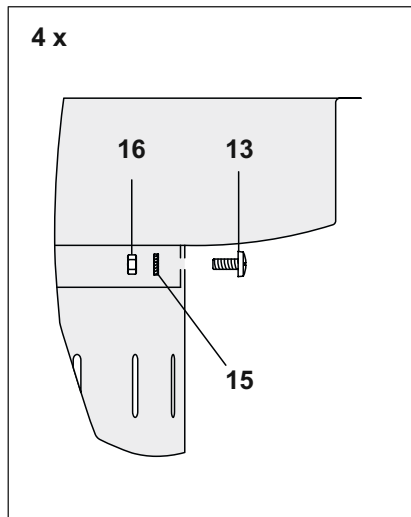
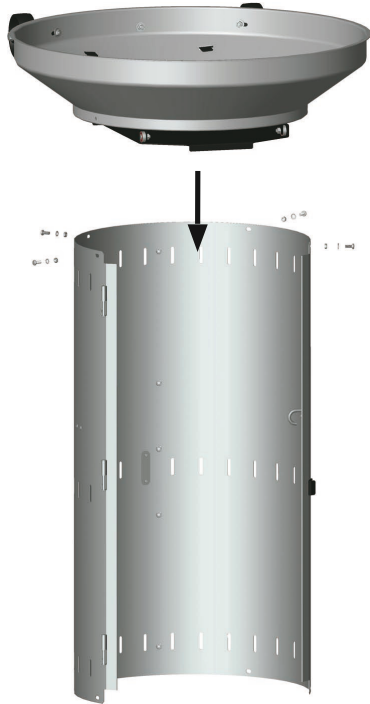

6

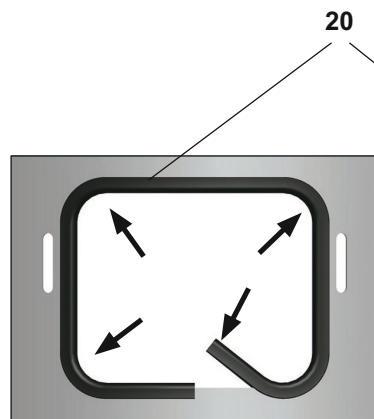

7

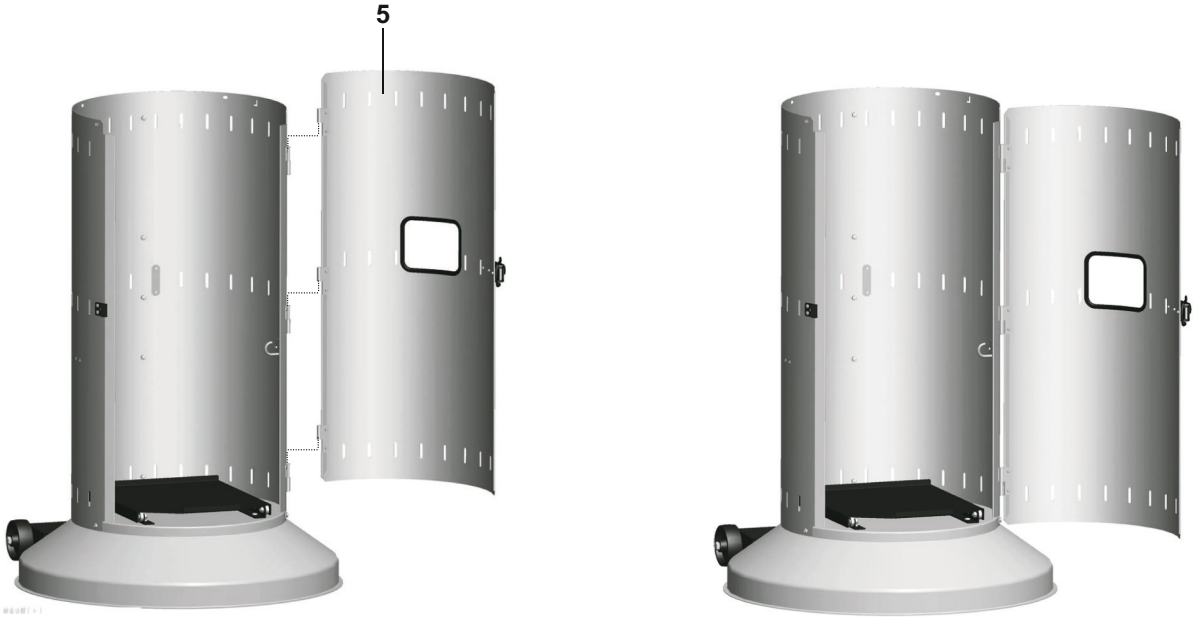

8

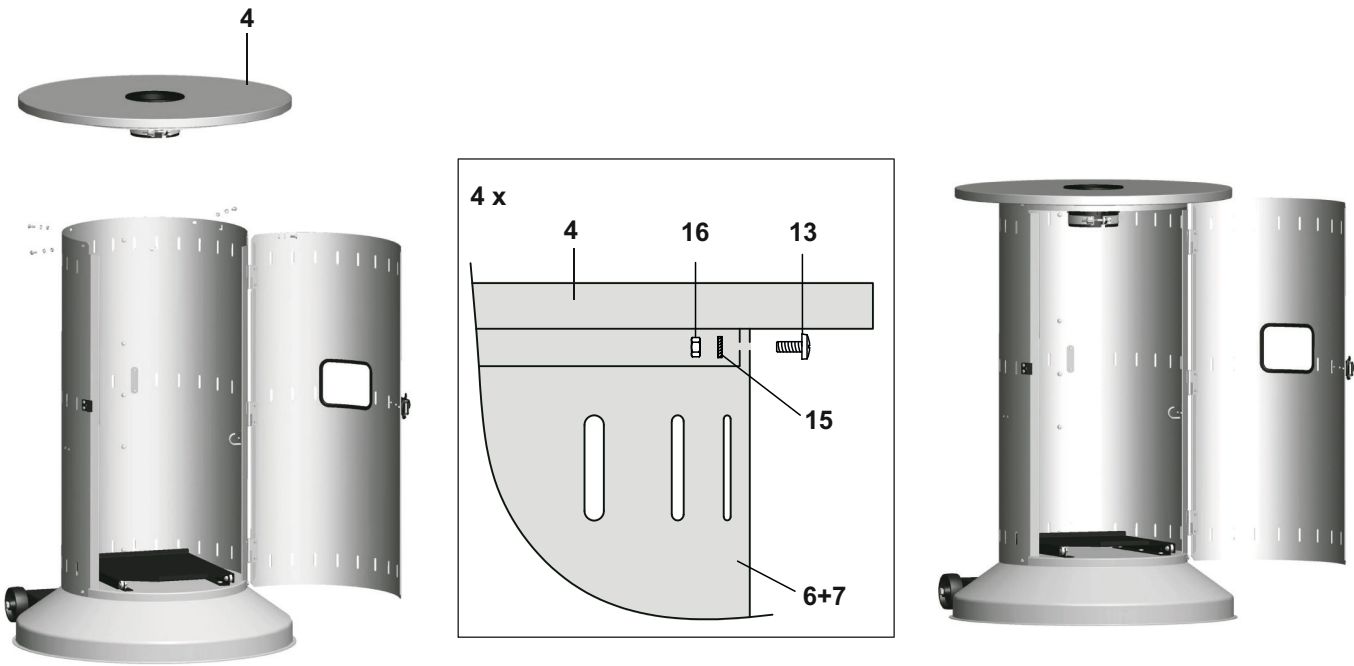

20

9

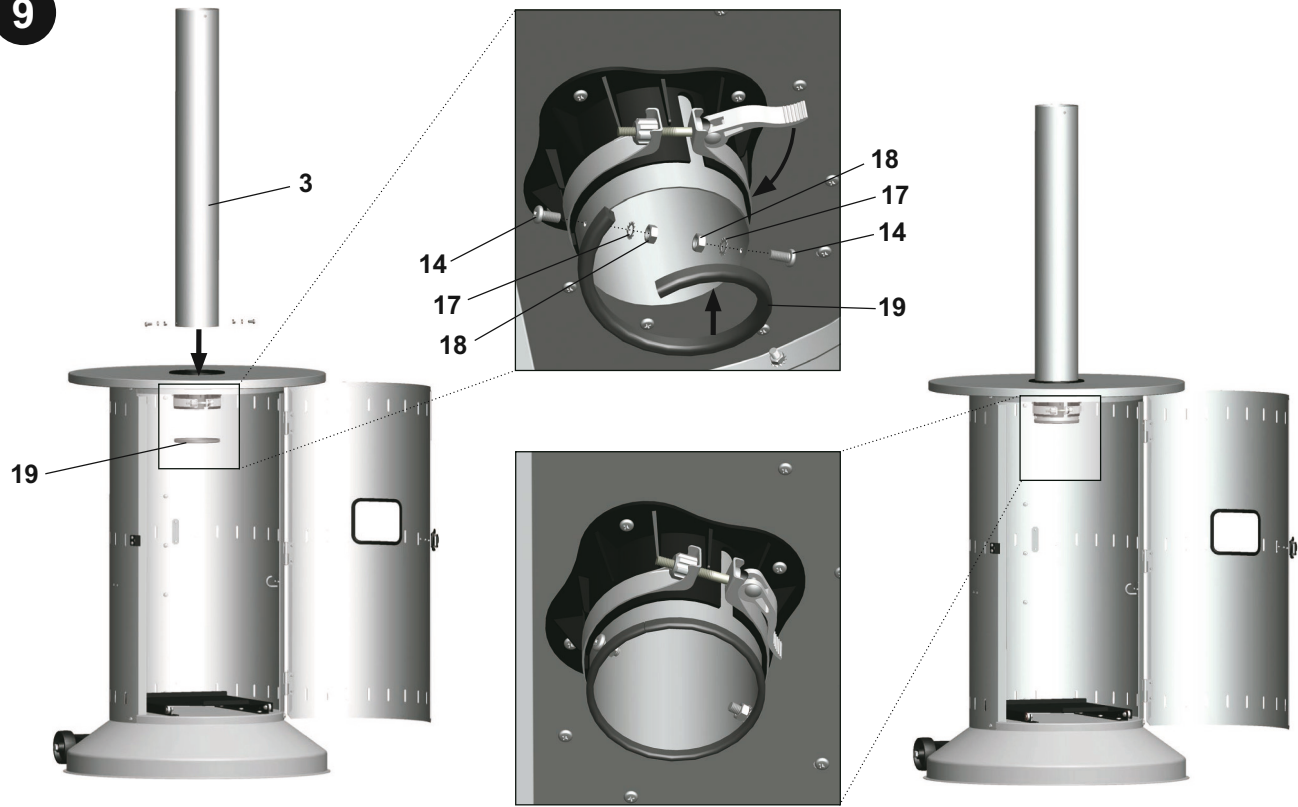

10

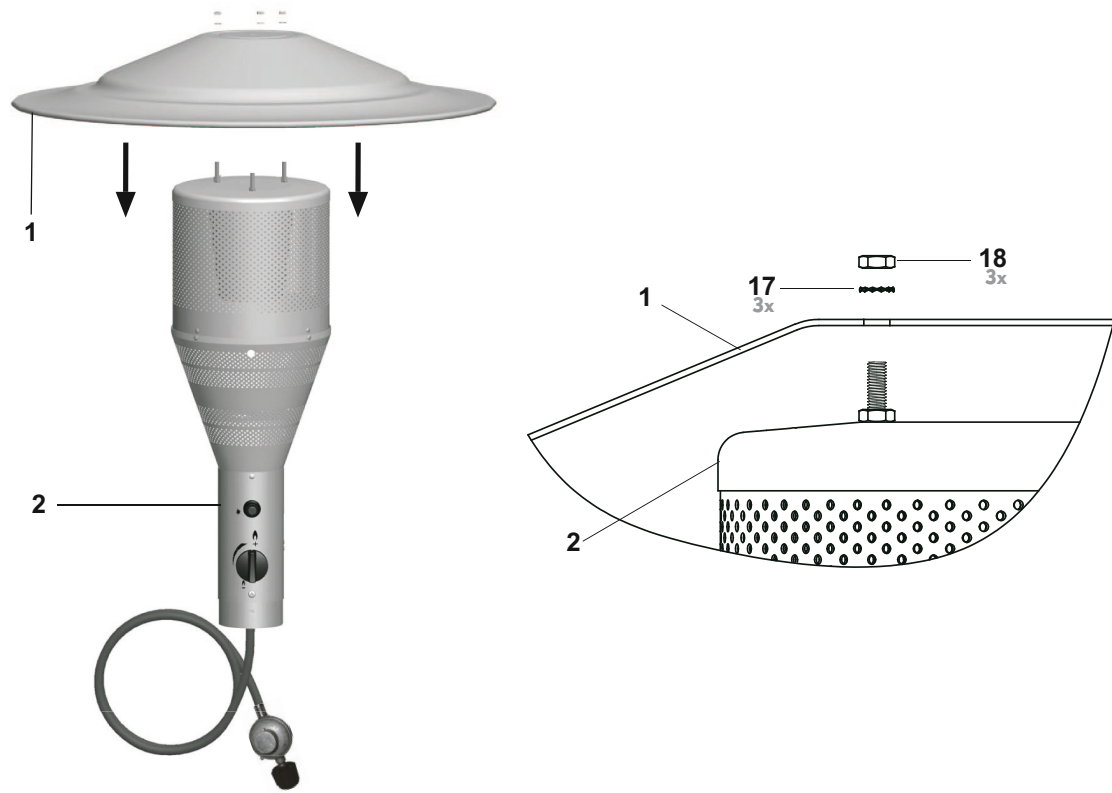

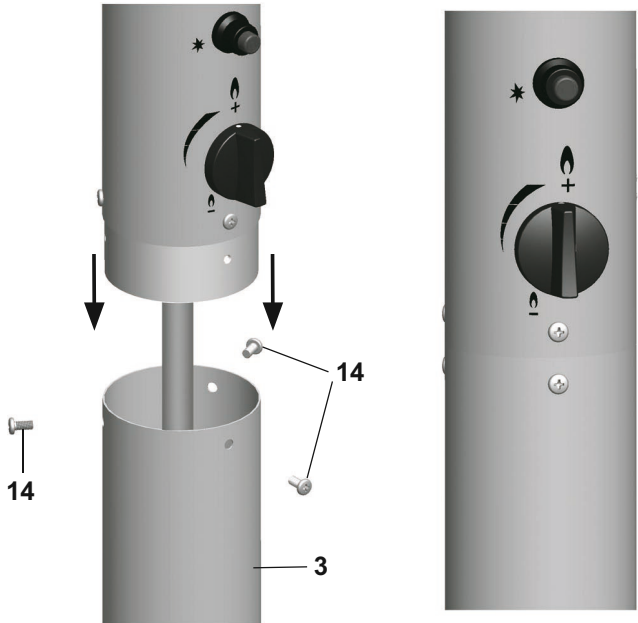
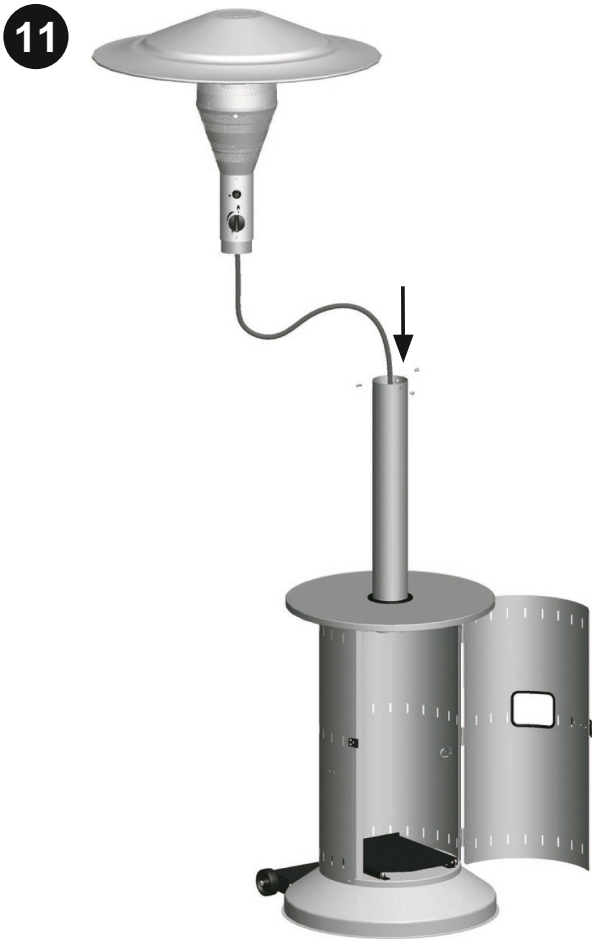

  
LEAK  
CHECKING  
see page 14



12

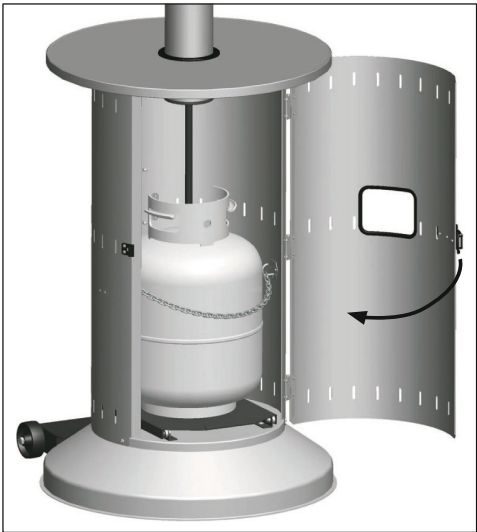
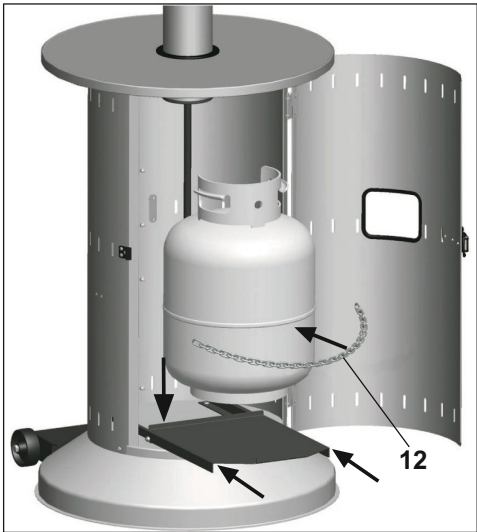

### 3. OPERATION

**Caution:** Do Not attempt to operate the heater until you have read and understood the warnings section in this manual.

**MOUNT THE HEATER ON THE GROUND FIRST!**

#### 3.1 TURNING THE GAS SUPPLY ON

**CONNECT THE GAS HOSE AND REGULATOR ASSEMBLY TO THE TANK**

**Note:** Use only a Department of Transportation (DOT) approved 20 pound cylinder with an ACME/ Type 1 connection with QCC (Quick Connect Coupler)safety valves. When the Cylinder is empty it should weighth 18 pounds.

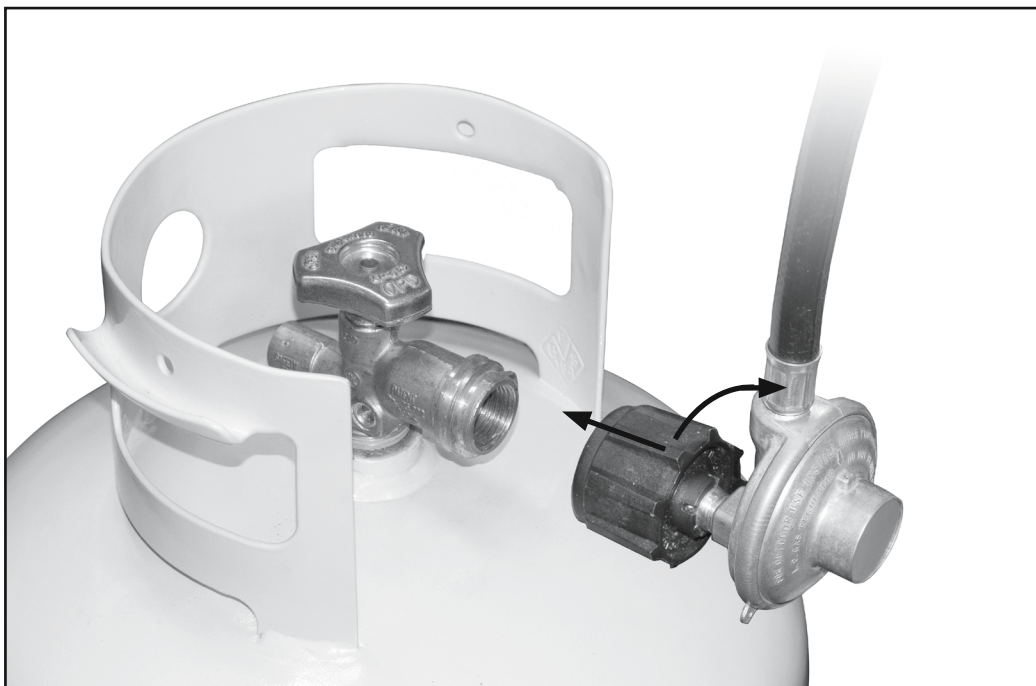

#### CHECK FOR LEAKS:

Make a solution of 2-3 oz. of leak checking solution by mixing one part liquid dishwashing soap and three parts water. Follow the procedure below:

##### LEAK CHECKING FUEL TUBE CONNECTION

Step 1: Turn cylinder valve on by turning anti-clockwise.

Step 2: Check fuel tube connection for leaks.

To check for leaks spoon several drops of solution onto the connections as illustrated.

Step 3: Inspect the solution for bubbles. If no bubbles appear then the connection is secure.

**If bubbles appear, then there is a leak: Turn OFF the cylinder valve.**

Undo the connection and inspect the surface of the cone to make sure they are clean.

Reconnect by using two wrenches, one on either side of the connection.

Repeat the leak checking procedure described above.

**If you still see bubbles after several attempts**

**DO NOT USE THE HEATER.**

**Contact service for assistance.**

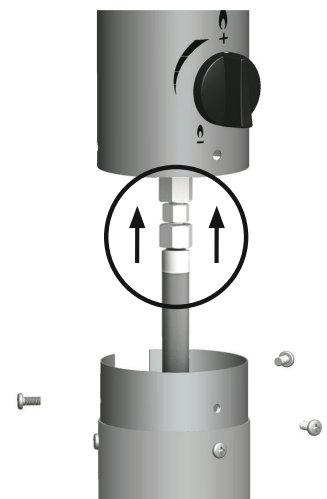

**LEAK CHECKING GAS LINE AND CYLINDER CONNECTIONS**

- Step 1: Turn cylinder valve on by turning anti-clockwise.
- Step 2: Check connections and valve for leaks. To check for leaks spoon several drops of solution onto the connections as illustrated.
- Step 3: Inspect the solution for bubbles, if no bubbles appear then the connection is secure.

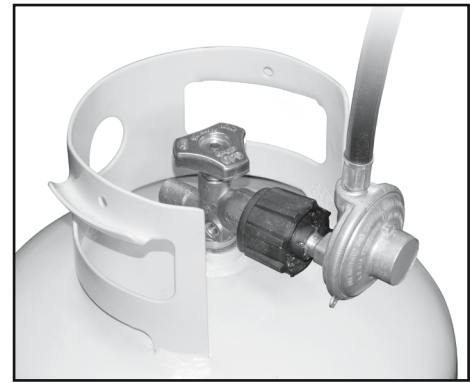

**If bubbles appear, then there is a leak:  
Turn OFF the cylinder valve.**

Release the regulator connection to the cylinder.  
Reattach the regulator, making sure that the connection is tight.  
Repeat the leak checking procedure described above.

**If you still see bubbles after several attempts  
DO NOT USE THE HEATER.  
Contact service for assistance.**

- Your heater was designed and approved for Outdoor use only. Do NOT use it inside an enclosure.
- Make sure that all combustibles are maintained and that there are no flammable liquids or vapors in the vicinity of the heater.
- Make sure there is no obstruction to air ventilation.
- Be sure that all gas connections are tight and there are no leaks.
- Any components removed during the assembly or servicing of the heater must be reinstalled.

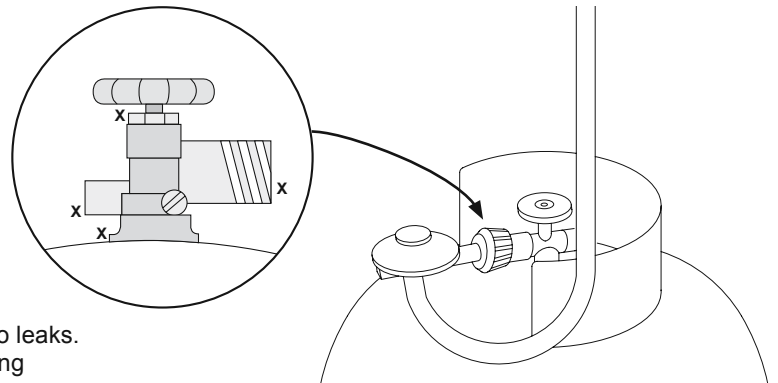

**3.2 BEFORE LIGHTING**

- The heater components should be thoroughly inspected before each use and at least every two years by a qualified service person.
- Inspect the visible portion of the hose before each use of the appliance. Portions that are located within the heater post, inspect the entire hose assembly at least annually.
- The hose assembly must be replaced prior to the appliance being put into operation if there is evidence of excessive abrasion or wear, or if the hose is damaged. The replacement hose assembly shall be that specified by the manufacturer.

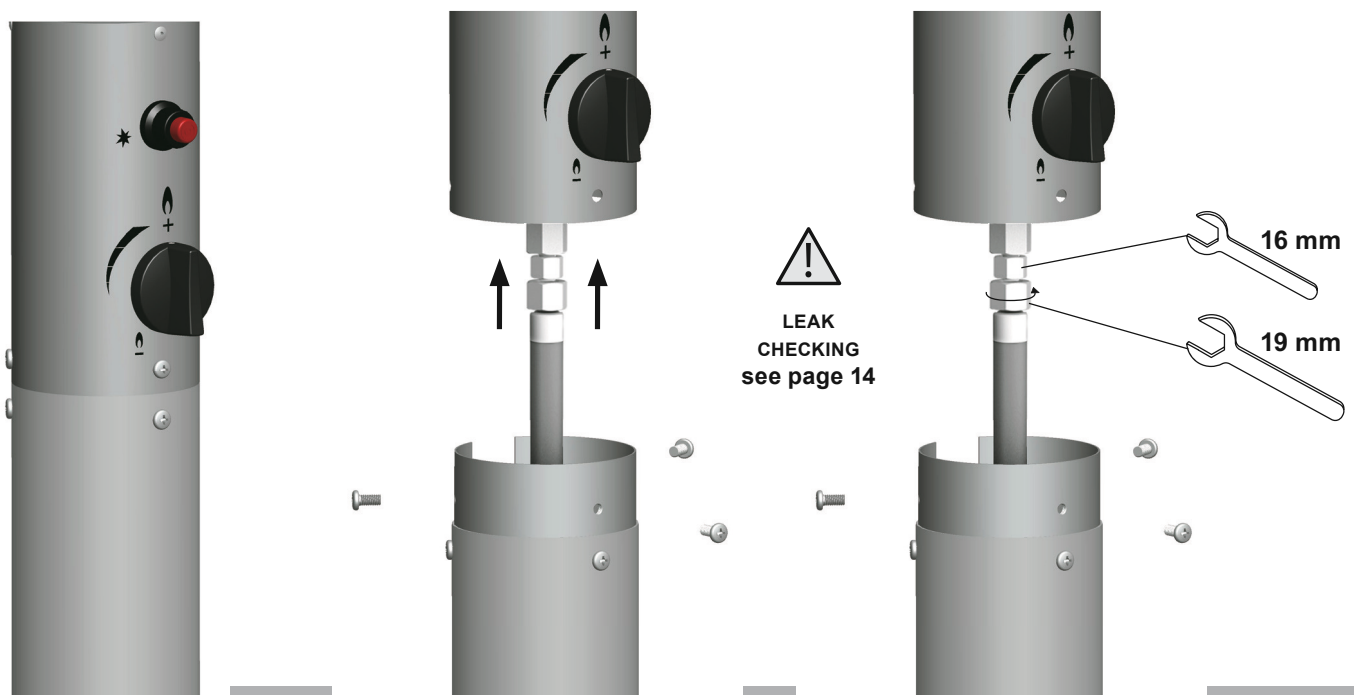

### 3.3 LIGHTING

1. Push control knob IN and turn to OFF.
2. Turn the gas tank valve ON.
3. Depress the burner control knob and turn it (anticlockwise) to the igniting position. ✱
4. Press the piezo-ignition concurrently with your other hand and hold the pressed knob for about 10 seconds after ignition in order to activate the ignition safety switch. Should the gas fail to ignite after pressing the piezo-ignition 3 or 4 times, leave the appliance for about 5 minutes that any gas to clear and then repeat the process.

**Note:**

**It is possible to ignite the burner using other ignition devices (gas lighters, matches) through the 0.73 inch aperture in the bottom of the burner.**

**Caution:**

Avoid inhaling fumes emitted from the heater's first use. Smoke and odour from the burning of oils used in manufacturing will appear. Both smoke and odor will dissipate after approximately 30 minutes. The heater should NOT produce thick black smoke.

**Note:**

The burner may be noisy when initially turned on. To eliminate excessive noise from the burner, turn the Control Knob to the small flame position. Then, turn the knob to the level of heat desired.

### 3.4 WHEN HEATER IS "ON"

Emitter screen will become bright red due to intense heat. The colour is more visible at night. Burner will display tongues of blue and yellow flame. These flames should not be yellow or produce thick black smoke, indicating an obstruction of airflow through the burners. The flame should be blue with straight yellow tops.

### 3.5 RE-LIGHTING

Turn Control Knob to OFF

Wait at least 5 minutes, to let gas dissipate, before attempting to relight.

Repeat the "Lighting" steps on prior page.

### 3.6 SHUTDOWN

1. Turn the burner control knob clockwise to the igniting position. ✱
2. Depress the control knob and turn it clockwise to OFF.
3. Turn tank valve clockwise to OFF. Disconnect the regulator when heater is not in use.

Place dust cap on cylinder valve outlet whenever the cylinder is not in use. Only install the type of dust cap on the cylinder valve outlet that is provided by the cylinder valve. Other types of caps or plugs may result in leakage of propane.



**WARNING**

**FOR YOUR SAFETY**

**Be careful when attempting to manually ignite this heater. Holding in the control knob for more than 5 seconds before igniting the gas will cause a ball of flame upon ignition.**



**WARNING**

**FOR YOUR SAFETY**

**Heater will be hot after use**

**Handle with extreme care**

#### **4. OPERATION CHECKLIST**

**For a safe and pleasurable heating experience, perform this check before each use.**

##### **BEFORE OPERATING**

- I am familiar with entire owner's manual and understand all precautions noted in "Safety First".
- All components are properly assembled, intact and operable.
- No alterations have been made.
- All gas connections are secure and do not leak.
- Wind velocity is below 10 mph.
- Outdoor temperature is greater than 40 degrees F.
- Heater is outdoors (outside any enclosure).
- There is adequate fresh air ventilation.
- Heater is away from gasoline or other flammable liquids or vapors.
- Heater is away from windows, air intake openings, sprinklers and other water sources.
- Heater is at least 36" clearance (top) and 24" clearance (side) of combustible materials.
- Heater is on a hard and level surface.
- There are no signs of spiders or insect nests.
- All burner passages are clear.
- All air circulation passages are clear.
- Children, pets, clothing, flammable materials and items that can be damaged from radiant heat are away from the heater.
- Children and adults in the area have been alerted to the high temperature hazards: especially burns and clothing fires.
- Children and adults in the area have been warned not to touch the heater near the burner during operation  
and until unit has cooled.

##### **AFTER OPERATION**

- Gas control is in OFF position.
- Gas tank valve is OFF
- Disconnect Gas Line.
- Heater is upright in a secure location.

## 5. CLEANING AND MAINTENANCE

Your heater has been produced from highly weather resistant materials and only minimum cleaning and maintenance is required. Cleaning must be performed when the heater is cold. Your patio heater will live longer if it is cleaned and maintained properly. It is very important that the air required for the combustion process is not blocked going to the burner. Vents and other openings must be kept free of dirt and spiders webs. The burner lower part is one unit. You can not clean it.

### **Stainless steel models:**

Use a stainless steel cleaner product on the main components of the heater, cylinder cover, base and post. Never use a cleaning agent that is flammable or corrosive. Never spray any cleaning product on the emitter grid or burner area.

### **Painted models:**

Wash all painted parts of the heater with a soapy solution and protect it with a coat of automobile car wax a couple of times per year or as required dependent upon your local weather and climate conditions. If you need to touch up a painted heater only paint the post and base portions. Never paint the emitter grid, lighting instructions, valve or control knob area or the LP cylinder!

The burner ports must also be kept clear so that the burner burns evenly and the flow of gas is not restricted. If the heater is not performing adequately it will be necessary to check the burner.

In a salt air or ocean environment, corrosion and rust occur at a far greater rate than in non-ocean areas. You will need to check more frequently for corrosion and replace parts as required.

## 6. STORAGE

- Turn control knob OFF
- **Disconnect LP source and move to secure, well-ventilated location outdoors.**
- Store heater upright in an area sheltered from direct contact with inclement weather (such as rain, sleet, hail, snow, dust and debris).
- If desired, cover heater to protect exterior surfaces and to help prevent build up in air passages.
- **Never leave the LP cannister exposed to direct sunlight or excessive heat.**
- Note: Wait until heater is cool before covering.
- If using a cover, ensure it is tightly fitted or secured support it during high winds.



## **7. SPECIFICATIONS**

**Certifications:**

ANS Z83.26/CSA 2.37-2007  
Gas Fired Outdoor Infrared Patio Heater

**Rating:**

Maximum 48,000 BTU/hr. input

**Heat Range:**

Up to 20 foot diameter

**Fuel:**

Liquid Propane Gas (LP)

**Tank Size:**

Nominal 20 lb / 5 Gallon

**Inlet gas supply pressure:**

Maximum 150 PSI  
Minimum 5 PSI

**Mainfold Pressure:**

11.00 in.w.c.

**Safety Features:**

100% Burner shut-off  
Tilt switch

**Manufacturer:**

Enders Colman AG

**Made in:**

P. R. China

## **8. SERVICE ADDRESS**

**Before returning to your retailer, call our customer service hotline at 1-866-985-7877, 9 a.m. – 6 p.m., EST, Monday – Friday or email at [cservice@welltraveled.net](mailto:cservice@welltraveled.net).**

**Well Traveled Living**

P.O. Box 4  
Amelia Island, FL 32035  
Email: [cservice@welltraveled.net](mailto:cservice@welltraveled.net)

**Distributed By:**

Well Traveled Living  
716 S 8<sup>th</sup> Street  
Amelia Island, FL 32034  
Toll Free: 866-WTL-SUPP



Web: [www.wtliving.com](http://www.wtliving.com)  
Email: [cservice@welltraveled.net](mailto:cservice@welltraveled.net)

**1 YEAR LIMITED WARRANTY – Customers in the Continental US**

All components are warranted for a period of 1 year after date of purchase by the original owner against defects in materials and workmanship under normal use. This warranty does NOT cover normal wear and weathering, assembly and/or maintenance OR use in a commercial application if model is not designated as a commercial model. At Well Traveled Living's sole discretion, products under warranty will be repaired and/or replaced at no charge to the customer. Any returns sent back to Well Traveled Living must be sent via prepaid freight and in the original retail packaging.

For warranty service contact Well Traveled Living at the address, phone numbers or internet site and email listed in this owner's manual. Be sure to have your sales receipt, date of purchase and catalogue/model numbers available when calling. All warranty service will be coordinated by the Well Traveled Living's, Amelia Island, Florida service center.

This warranty is extended only to the original purchaser. Proof of purchase will be required before warranty service is rendered. The sales receipt is the only valid proof of purchase. This warranty only covers failures due to defects in materials or workmanship which occur during normal use. Failures and/or damage which result from accident, negligence, misuse, abuse, neglect, mishandling, alteration or modification, failure to maintain, improper assembly or maintenance, service by unauthorized agency or use of unauthorized components or damage that is attributable to acts of God are NOT covered.

**\*\*\*THERE ARE NO EXPRESS WARRANTIES EXCEPT AS LISTED ABOVE\*\*\***

**\*\*\*PURCHASER ASSUMES ALL RISKS IN THE ASSEMBLY AND OPERATION OF THIS UNIT\*\*\***

**\*\*\*FAILURE TO FOLLOW WARNINGS AND OPERATIONAL INSTRUCTIONS CONTAINED IN THIS MANUAL CAN RESULT IN SEVERE PROPERTY DAMAGE AND/OR PERSONAL INJURY\*\*\***

**IN NO EVENT WILL WELL TRAVELED LIVING, OR ITS DIRECTORS, OFFICERS OR AGENTS BE LIABLE TO THE PURCHASER OR ANY THIRD PARTY, WHETHER IN CONTRACT, IN TORT, OR ON ANY OTHER BASIS, FOR ANY INDIRECT, SPECIAL, PUNITIVE, EXEMPLARY, CONSEQUENTIAL, OR INCIDENTAL LOSS, COST, OR DAMAGE ARISING OUT OF OR IN CONNECTION WITH THE SALE, MAINTENANCE, USE, OR INABILITY TO USE THE PRODUCT, EVEN IF WELL TRAVELED LIVING OR ITS DIRECTORS, OFFICERS OR AGENTS HAVE BEEN ADVISED OF THE POSSIBILITY OF SUCH LOSSES, COSTS OR DAMAGES, OR IF SUCH LOSSES, COSTS, OR DAMAGES ARE FORESEEABLE. IN NO EVENT WILL WELL TRAVELED LIVING, OR ITS OFFICERS, DIRECTORS, OR AGENTS BE LIABLE FOR ANY DIRECT LOSSES, COSTS OR DAMAGES THAT EXCEED THE PURCHASE PRICE OF THE PRODUCT.**

**SOME JURISDICTIONS DO NOT ALLOW THE EXCLUSION OR LIMITATION OF INCIDENTAL OR CONSEQUENTIAL DAMAGES, SO THE ABOVE LIMITATION OR EXCLUSION MAY NOT APPLY TO THE PURCHASER.**

This limited warranty gives you specific legal rights and you may also have other rights which vary from jurisdiction to jurisdiction. The provisions of the United Nations Convention on Contracts for the Sales of Goods shall not apply to this limited warranty or the sale of products covered by this limited warranty.

**\*\*\*IMPORTANT NOTICE\*\*\***

-Do **NOT** return to place of purchase-

For customer service and warranty issues

contact our Customer Service Center at:

(866)-985-7877 OR

Email: [cservice@welltraveled.net](mailto:cservice@welltraveled.net)

Customer Service Hours: Mon. – Fri. 9:00 a.m. – 6:00 p.m. (EST)

Fire Sense®, Mojave Sun®, and Well Traveled Living® are registered trademarks of Well Traveled Imports, Inc®. All assembly instruction presentations are the property of Well Traveled Imports, Inc.® and are protected by U.S. copyrights and trademarks. All rights reserved.