

# 800 SERIES

## ARTICULATING BOOM LIFT



### Performance

Platform Height	80 ft	24.38 m
Horizontal Outreach		
800A	53 ft	16.15 m
800AJ	51 ft 10 in.	15.8 m
Up and Over Height	32 ft 1 in.	9.78 m
Swing	360 Degrees Continuous	
Platform, Side Entry	36 x 96 in.	0.91 x 2.44 m
Platform Capacity-Restricted		
800A only	1000 lb*	454 kg
Platform Capacity-Unrestricted	500 lb	227 kg
Platform Rotator	180 Degrees Hydraulic	
Jib Length		
800AJ	6 ft	1.83 m
Jib Range of Articulation		
800AJ	130 Degrees (+70, -60)	
Weight**	34,738 lb	15,757 kg
Max. Ground Bearing Pressure	76 psi	5.3 kg/cm <sup>2</sup>
Drive Speed 2WD or 4WD	3.0 mph	4.8 km/h
Gradeability		
2WD	30%	
4WD	45%	
Tilt Cut Out	4 Degrees	
Turning Radius (Inside)		
2WS / 4WS	12 ft / 7 ft	3.66 m / 2.13 m
Turning Radius (Outside)		
2WS / 4WS	22 ft 6 in. / 14 ft 6 in.	6.86 m / 4.42 m

### Standard Specifications

#### Power Source

Dual Fuel Engine		
GM Vortec 3000 MPFI	82 hp	61 kW
Diesel Engine		
Deutz TD2.9L4 Tier 4 Final	67 hp	50 kW
Fuel Tank Capacity	39 gal.	147.6 L

#### Hydraulic System

• Capacity	40 gal.	151.4 L
• Auxiliary Power	12V DC	

#### Tires

• Standard	15-62S Foam Filled Wide Lug Tread
• Optional	18 x 62S Non Marking Foam Filled Tires 18-22.5 Sand/Turf Foam Filled Tires

### Standard Features

- Oscillating Axle
- Articulating Jib (800AJ only)
- Dual Rated Capacities (800A only)
- Oscillating Axle
- 180 Degree Hydraulic Platform Rotator
- 110V-AC Receptacle in the Platform
- 4 Degree Tilt Alarm/Indicator Light
- Swing-Out Engine Tray
- 12V-DC Auxiliary Power
- Hourmeter
- Control ADE® System
- Proportional Controls
- Gull-Wing Hoods
- Hydrostatic Drive
- Platform Console Machine
- Status Light Panel
- Lifting/Tie Down Lugs
- Engine Distress Warning
- Rim Protector Lug Tread Tires
- Engine Distress Shutdown — Selectable via Analyzer
- All Motion Alarm
- Load Sensing System
- SkyGuard SkyLine™



### Accessories & Options

- Platform: 36 x 72 in. (0.91 x 1.83 m)
- Operator Tool Tray
- Fall Arrest Platform, Rear Entry: 30 x 72 in. (0.76 x 1.83 m)
- Inward Self-Closing Swinging Gate
- Soft Touch System: 6 ft/8 ft
- SkySense™
- 43.5 lb (19.7 kg) Propane Tank
- Cold Weather Start Kit (GM)<sup>1</sup>
- Cold Weather Start Kit (Deutz)<sup>1</sup>
- Hostile Environment Kit<sup>2</sup>
- Light Package<sup>3</sup>
- Flashing Amber Beacon
- Arctic Package<sup>4</sup>
- SkyWelder®
- SkyPower® Package — 7500 Watt Generator, power cable to platform, 1/2 in. Air Line to Platform

\* Provides indicator lights at platform control console for system distress, 5 degree tilt light, and foot switch status.

1. Includes glow plugs (Diesel), battery heater, oil tank heater.

2. Includes console cover, boom wipers and cylinder bellows.

3. Includes head and tail lights, platform worklights and beacon.

4. Includes arctic hydraulic hoses (drive and steer only) and main boom cable, arctic hydraulic oil, extreme cold engine oil, fuel conditioner, engine block heater, battery blanket, glow plugs, hydraulic tank heater, and oversized footswitch.

Note: Some options may increase lead time, and some option combinations may not be available.

Additional accessories and options available via JLG Aftermarket.

# 800 SERIES

ARTICULATING BOOM LIFT



## Dimensions

All dimensions are approximate.

800A

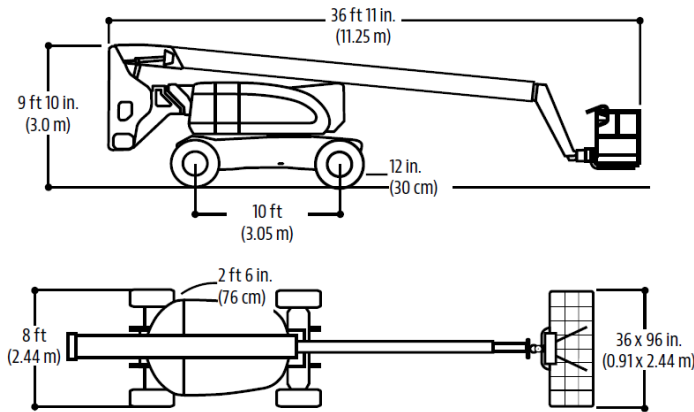

800AJ

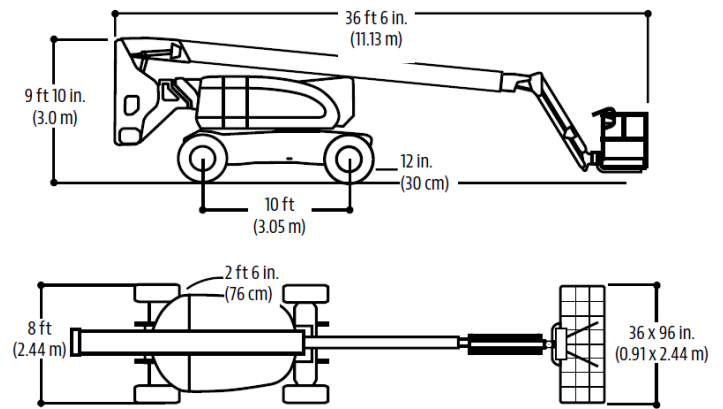

## Reach Diagram

800A

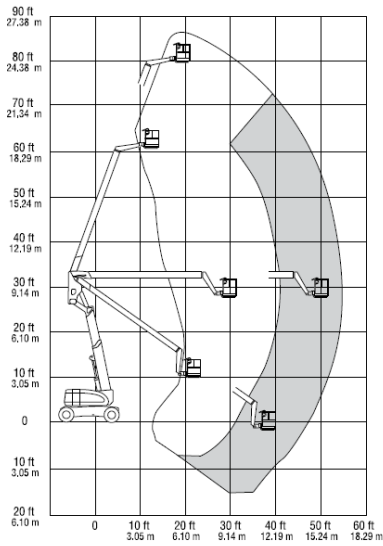

800AJ

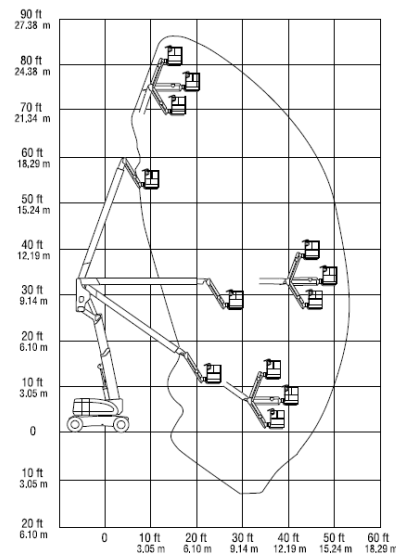

## The JLG "1 & 5" Warranty

We provide coverage for one (1) full year, and cover all specified major structural components for five (5) years. Due to continuous product improvements, we reserve the right to make specification and/or equipment changes without prior notification. This machine meets or exceeds applicable ANSI and CSA requirements based on machine configuration as originally manufactured for intended applications. Please reference the serial number plate on the machine for additional information.

Part No.: 3131108  
R1219\_A92.20  
Printed in USA

**JLG Industries, Inc.**  
1 JLG Drive  
McConnellsburg, PA 17233-9533  
Telephone 717-485-5161  
Toll-free in US 877-JLG-LIFT  
Fax 717-485-6417  
[www.jlg.com](http://www.jlg.com)

**An Oshkosh Corporation Company**