

Shark

Lift-Away[®] XL Upright Vacuum

UV550 Series

OWNER'S GUIDE



IMPORTANT SAFETY INSTRUCTIONS

FOR HOUSEHOLD USE ONLY • PLEASE READ CAREFULLY BEFORE USE

If the plug does not fit fully into the outlet, reverse the plug. If it still does not fit, contact a qualified electrician. **DO NOT** force into outlet or try to modify to fit.

WARNING

To reduce the risk of fire, electric shock, injury, or property damage:

GENERAL WARNINGS

When using an electrical appliance, basic precautions should always be followed, including the following:

1. Your vacuum cleaner may consist of a motorized nozzle, wand, hose, and/or vacuum canister. This device contains electrical connections, electrical wiring, and moving parts that potentially present risk to the user.
2. Use only identical replacement parts.
3. Carefully observe and follow the instructions provided below to avoid improper use of the appliance. **DO NOT** use the vacuum for any purpose other than those described in this manual.
4. Before use, carefully inspect all parts for any damage. **DO NOT** use if any parts are damaged.
5. The use of an extension cord is **NOT** recommended.
6. This vacuum cleaner contains no serviceable parts.

USE WARNINGS

7. This appliance can be used by persons with reduced physical, sensory or mental capabilities or lack of experience and knowledge if they have been given supervision or instruction concerning use of the appliance in a safe way and understand the hazards involved. Cleaning and user maintenance shall not be made by children. Keep the appliance and its cord out of reach of children. **DO NOT** allow the appliance to be used by children. **DO NOT** allow to be used as a toy. Close supervision is necessary when used near children.

8. Always turn off the vacuum cleaner before connecting or disconnecting any motorized nozzles or other accessories.
9. **DO NOT** handle plug or vacuum cleaner with wet hands.
10. **DO NOT** use without filters in place.
11. Only use Shark® branded filters and accessories. Failure to do so will also void the warranty.
12. **DO NOT** damage the power cord:
 - a) **DO NOT** pull or carry vacuum cleaner by the cord or use the cord as a handle.
 - b) **DO NOT** unplug by pulling on cord. Grasp the plug, not the cord.
 - c) **DO NOT** run the vacuum cleaner over the power cord, close a door on the cord, pull the cord around sharp corners, or leave the cord near heated surfaces.
13. **DO NOT** put any objects into nozzle or accessory openings. **DO NOT** use with any opening blocked; keep free of dust, lint, hair, and anything that may reduce airflow.
14. **DO NOT** use if nozzle or accessory airflow is restricted. If the air paths or the motorized floor nozzle become blocked, turn the vacuum cleaner off and unplug from electrical outlet. Remove all obstructions before you plug in and turn on the unit again.
15. Keep nozzle and all vacuum openings away from hair, face, fingers, uncovered feet, or loose clothing.

16. **DO NOT** use if vacuum cleaner is not working as it should, or has been dropped, damaged, left outdoors, or dropped into water.
17. Use extra care when cleaning on stairs.
18. **DO NOT** leave the vacuum cleaner unattended while plugged in.
19. When powered on, keep the vacuum cleaner moving over the carpet surface at all times to avoid damaging the carpet fibers.
20. **DO NOT** place vacuum cleaner on unstable surfaces such as chairs or tables.
21. Your Shark® vacuum may not be designed to stand up on its own. When taking a break from cleaning, you may need to lean it against furniture or a wall, or lay it flat on the floor. Using the vacuum for an application where the unit lacks stability may result in personal injury.
22. **DO NOT** use to pick up:
 - a) Liquids
 - b) Large objects
 - c) Hard or sharp objects (glass, nails, screws, or coins)
 - d) Large quantities of dust (drywall dust, fireplace ash, or embers). **DO NOT** use as an attachment to power tools for dust collection.
 - e) Smoking or burning objects (hot coals, cigarette butts, or matches)
 - f) Flammable or combustible materials (lighter fluid, gasoline, or kerosene)
 - g) Toxic materials (chlorine bleach, ammonia, or drain cleaner)
23. **DO NOT** use in the following areas:
 - a) Poorly lit areas
 - b) Wet or damp surfaces
 - c) Outdoor areas
 - d) Spaces that are enclosed and may contain explosive or toxic fumes or vapors (lighter fluid, gasoline, kerosene, paint, paint thinners, mothproofing substances, or flammable dust)
24. Turn off all controls before plugging in or unplugging the vacuum.
25. Unplug from electrical outlet when not in use and before any maintenance or cleaning.
26. Hand wash with water only. Washing with cleaning chemicals could damage the unit.
27. During cleaning or routine maintenance, **DO NOT** cut anything other than hair, fibers, or string wrapped around the brushroll.
28. Allow all filters to air-dry completely before replacing in the vacuum to prevent liquid from being drawn into electric parts.
29. Make sure the dust cup and all filters are in place after routine maintenance.
30. If provided, secure the power cord around the two cord hooks during storage.

To reduce the risk of electric shock, this appliance has a polarized plug (one blade is wider than the other). This plug will fit in a polarized outlet only one way. If the plug does not fit fully in the outlet, reverse the plug. If it still does not fit, contact a qualified electrician to install the proper outlet. Do not change the plug in any way.

SAVE THESE INSTRUCTIONS

THANK YOU

for purchasing the Shark® Lift-Away® XL



Scan QR code using mobile device.



TIP: You can locate the date code on one of the prongs of the power cord plug.

REGISTER YOUR PURCHASE



registeryourshark.com

RECORD THIS INFORMATION

Model Number: _____

Date Code: _____

Date of Purchase (Keep receipt): _____

Store of Purchase: _____

TECHNICAL SPECIFICATIONS

Voltage: 120V, 60Hz

Watts: 1200W

Amps: 10A

PLEASE READ CAREFULLY AND KEEP FOR FUTURE REFERENCE.

This Owner's Guide is designed to help you get a complete understanding of your new Shark Lift-Away XL.

If you have any questions, please call Customer Service at 1-800-798-7398.

CONTENTS

Important Safety Instructions	3
Getting to Know Your Shark® Lift-Away® XL	6
Using Your Vacuum in Upright Mode	7
Assembling Your Vacuum.....	8
Power Cord.....	9
Settings.....	9
Brushroll Indicator Light.....	9
Lift-Away Mode	10
Above-Floor Cleaning.....	11
Lift-Away Cleaning With Nozzle.....	11
Storage	12
Maintenance	13
Emptying the Dust Cup.....	13
Cleaning the Pre-Motor Filters.....	13
Cleaning the Post-Motor HEPA Filter.....	14
Cleaning the Brushroll.....	14
Cleaning the Pet Hair Tool.....	14
Checking for Blockages.....	15
Ordering Additional Parts	16
Troubleshooting Guide	17
Warranty	18

GETTING STARTED

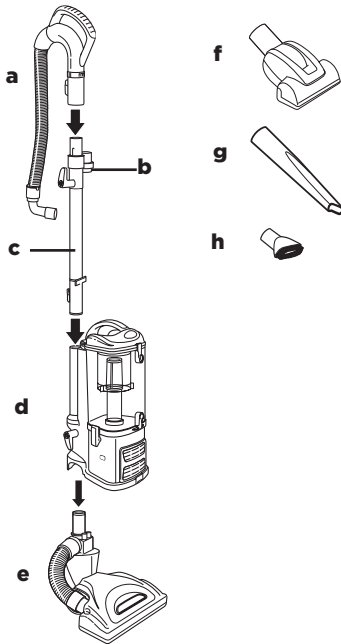

PARTS:

- a Handle with Stretch Hose
- b Accessory Holder
- c Wand
- d Detachable Canister
- e Motorized Floor Nozzle
- f Pet Hair Tool
- g 8" Crevice Tool
- h Dusting Brush

NOTE: There are a variety of accessories that are compatible with this vacuum series. The top flap of your box shows the select accessories that are included with your model.



Fig. 1



Fig. 4



Fig. 2



Fig. 3

ACCESSORIES:

CREVICE TOOL

Reach deep into narrow spaces and clean between cushions, under radiators and baseboards, and in hard-to-reach crevices and corners. **(Fig. 1)**

DUSTING BRUSH

Dust shelves, lamp shades, window blinds, books, furniture, and other upholstered household items. **(Fig. 2)**

ACCESSORY HOLDER

Designed to hold the crevice tool and dusting brush for quick access when vacuuming and cleaning around the house. **(Fig. 3)**

PET HAIR TOOL

This unique tool was engineered for fast and easy removal of pet hair and ground-in dirt from carpeted stairs and upholstery. **(Fig. 4)**

USING YOUR VACUUM IN UPRIGHT MODE

Use your **Shark® Lift-Away® XL** vacuum cleaner in upright mode, or lift away the canister to clean hard-to-reach areas above the floor.

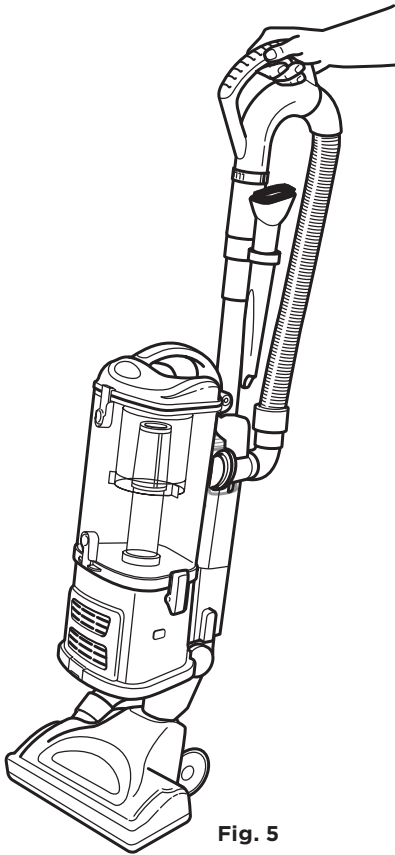

Fig. 5

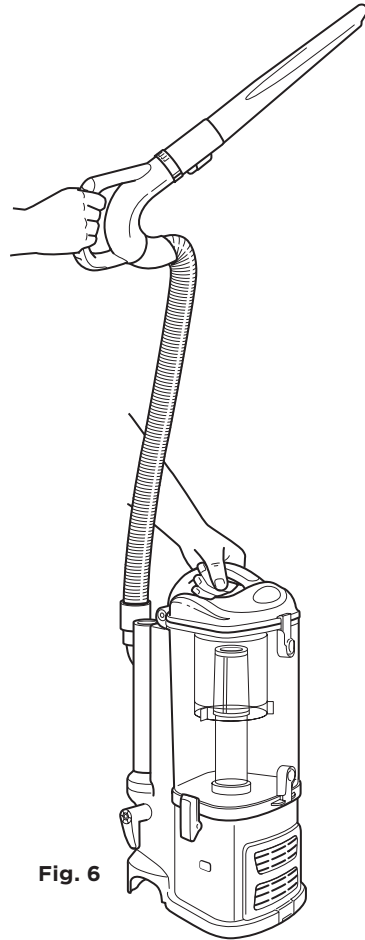

Fig. 6

1 UPRIGHT VAC

Upright vacuuming for cleaning both floors and carpets. **(Fig. 5)**

2 DETACHABLE CANISTER

Detach the canister and carry it to clean hard-to-reach spaces above the floor. **(Fig. 6)**

ASSEMBLING YOUR VACUUM

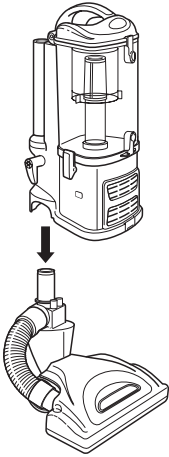

Fig. 7

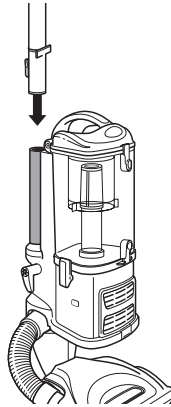

Fig. 8

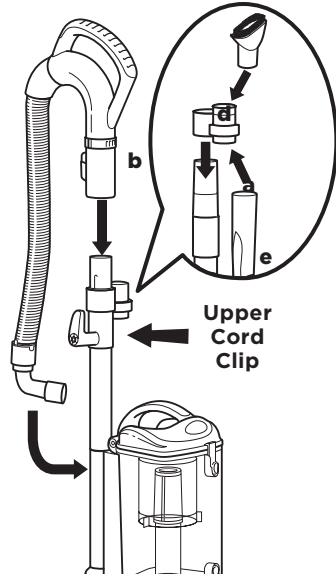

Fig. 9

- 1 Place the floor nozzle on a level surface.
- 2 Align the detachable canister over the tube on the floor nozzle. Lower the canister onto the floor nozzle until it clicks securely into place. **(Fig. 7)**
The unit will not power on unless the latching mechanism is completely locked into place.
- 3 Insert the wand into the tube on the back of the canister, pressing until it clicks securely into place. **(Fig. 8)**

- 4 Align the tab in the accessory holder **(a)** with the groove in the wand, then slide the holder down over the wand. **(Fig. 9)**
- 5 Insert the handle **(b)** into the top of the wand until it clicks into place. **(Fig. 9)**
- 6 Insert the end of the stretch hose with elbow connector **(c)** into the back of the canister. **(Fig. 9)**
- 7 Store the dusting brush **(d)** and the crevice tool **(e)** on the mounts of the accessory holder. **(Fig. 9)**

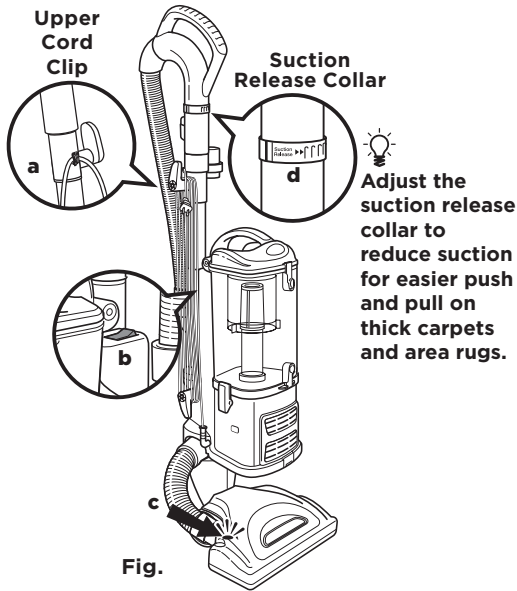

Fig.

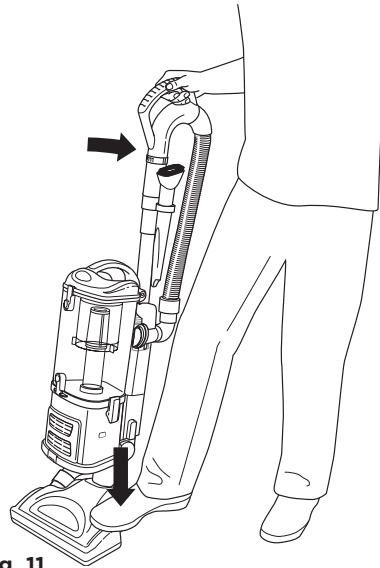

Fig. 11

POWER CORD:

- 1 Rotate the upper cord clip to quickly release the power cord.
- 2 Secure the power cord by wrapping it around the cord clips **(a)**. **(Fig. 10)**

SETTINGS:

|| = Brushroll ON

| = Bare Floor

○ = OFF



- 1 Press the selector switch **(b)** to Setting I to vacuum bare floors (straight suction only) or to Setting II to engage the brushroll (for vacuuming carpets and rugs). **(Fig. 10)**

BRUSHROLL INDICATOR LIGHT:

- 1 The brushroll indicator light **(c)** will illuminate green when the brushroll is on, or red if there is a blockage or jam. **(Fig. 10)** See Checking for Blockages on page 15.

- 2 To activate the brushroll, step lightly on the floor nozzle, then tilt the handle back. **(Fig. 11)**

NOTE: The brushroll will not spin unless the nozzle is flat against the floor and the handle is tilted back.

- 3 Increase or decrease suction power by adjusting the suction release collar **(d)** on the handle. **(Fig. 10)** If the vacuum seems difficult to push or pull, or if it is lifting up area rugs, reduce suction by rotating the collar counterclockwise. To increase suction and to vacuum floors, rotate the collar clockwise.
- 4 Empty dust cup after vacuuming and periodically during use when it appears full. (See Maintenance section for instructions.)
- 5 When you are finished vacuuming, move the switch to the Off position.

LIFT-AWAY® MODE



Use the handle on top of the dust cup to easily lift and carry the canister.

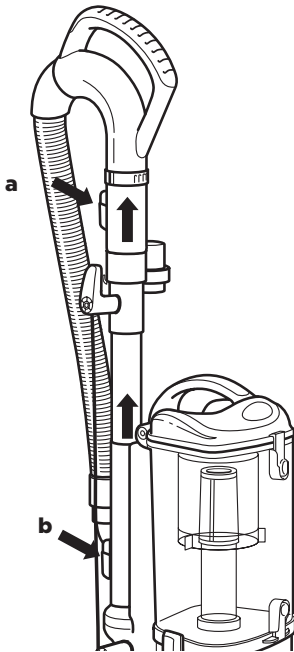

Fig. 12

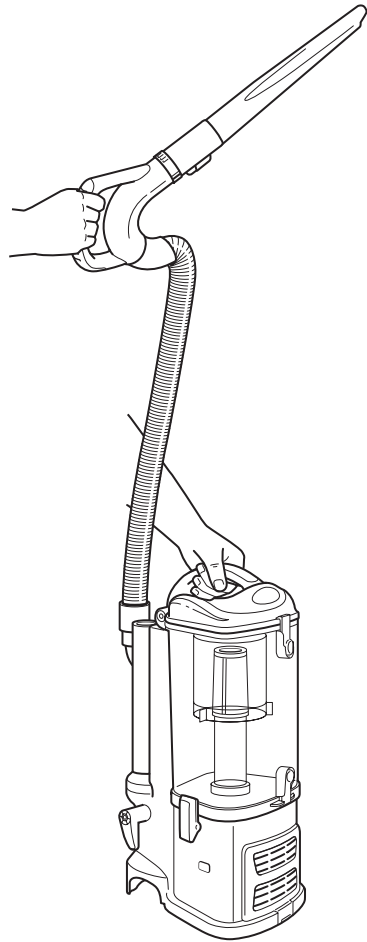
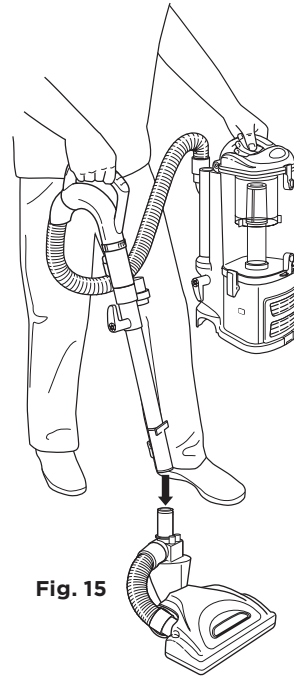
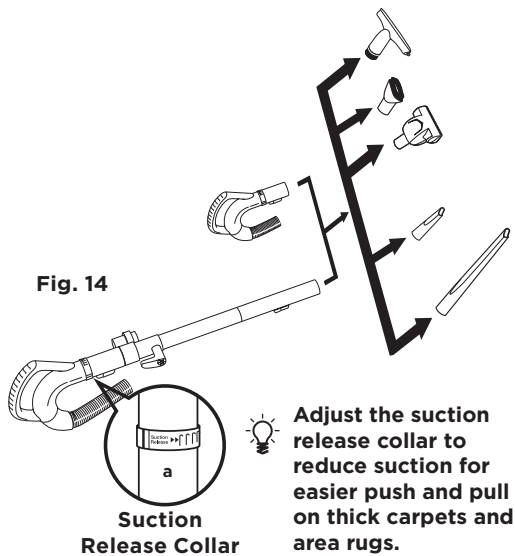

Fig. 13

LIFT AWAY® DETACHABLE CANISTER FOR PORTABLE CLEANING

- 1 Press the Lift-Away button, then lift the canister off the floor nozzle.
- 2 To clean with the handle, press the Handle Release button **(a)** and lift the handle out of the wand. To clean with longer reach, press the Wand Release button **(b)** and lift off the wand. **(Fig. 12)**
- 3 Attach an accessory onto the end of either the wand or the handle.
- 4 Move the selector switch to Setting I (Bare Floor) for above-floor cleaning. **(Fig. 13)**



ABOVE-FLOOR CLEANING

- 1** Press the handle release button to detach the handle or press the wand release button to detach the wand.
- 2** Attach an accessory onto the end of either the wand or the handle. **(Fig. 14)**
- 3** **Your vacuum has tremendous suction power. Increase or decrease suction power by adjusting the suction release collar on the handle. To reduce suction for lighter jobs such as cleaning delicate surfaces like drapes, rotate the collar counterclockwise. To increase suction when cleaning floors or using accessories, rotate the collar clockwise. (Fig. 14)**
- 4** Move the selector switch to Setting I for above-floor cleaning.

LIFT-AWAY® CLEANING WITH NOZZLE

- 1** Press the wand release button and pull the wand up.
- 2** Attach floor nozzle onto the end of the wand. **(Fig. 15)**
- 3** Move the selector switch to Setting I.

NOTE: The brushroll will not spin in Lift-Away mode.

STORAGE

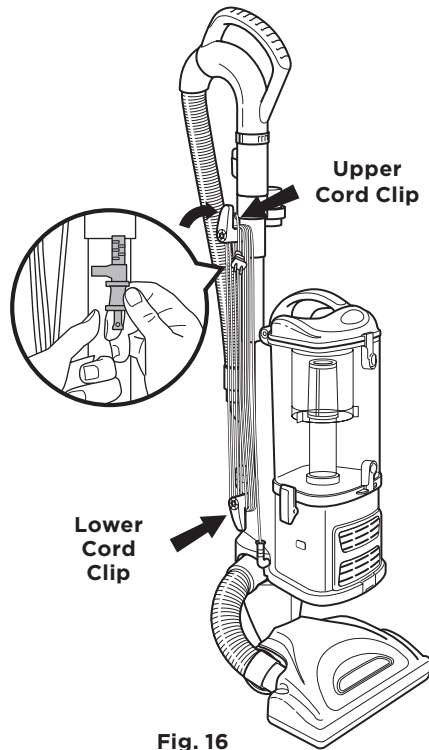

Fig. 16

STORE YOUR VACUUM SAFELY

- 1 Attach canister to floor nozzle to go into upright mode.
- 2 Rotate the upper cord clip to its upright position and coil the power cord loosely around the two clips. Clip the plug onto the cord to secure. **(Fig. 16)**
- 3 Store the dusting brush and the crevice tool on the mounts on the accessory holder.
- 4 Store your vacuum cleaner safely in a cool, dry area where it will not be a hazard, will not be damaged, and will not cause damage to anyone or anything.

NOTE: Empty dust cup after cleaning and prior to storing. (See Maintenance section for instructions.)

MAINTENANCE

COMPONENT	MAINTENANCE SCHEDULE
1 Dust Cup	Empty each time you vacuum.
2 Pre-Motor Foam Filter	Rinse and air-dry every 3 months under normal use.
3 Pre-Motor Felt Filter	Rinse and air-dry every 3 months under normal use.
4 Post-Motor HEPA Filter	Clean once every 2 years or as needed.

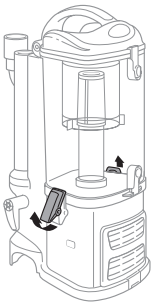

Fig. 17

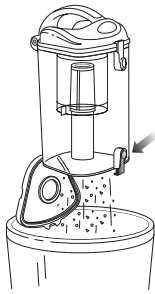

Fig. 18

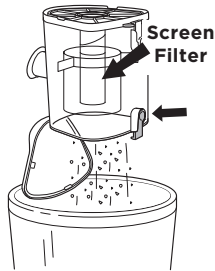

Fig. 19

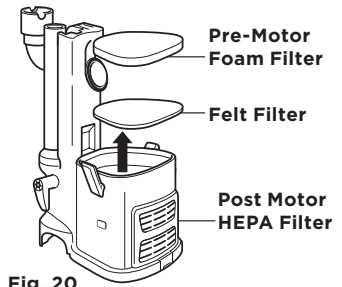

Fig. 20

EMPTYING THE DUST CUP

The dust cup needs to be emptied each time you vacuum and periodically during cleaning, when the dust cup appears full.

- 1 Remove the dust cup by lifting the side latches. **(Fig. 17)**
- 2 Hold the dust cup over a trash receptacle and press the bottom door release button. **(Fig. 18)** Tap gently to empty contents. Press the door shut again until it clicks.
- 3 If needed, turn the dust cup upside down over the trash receptacle and press the top door release button. **(Fig. 19)** Tap gently to remove contents.

Debris may get stuck to the screen filter inside the dust cup. Use a dry cloth or paper towel to remove debris. Press the top door shut again until it clicks.

- 4 Replace the dust cup on top of the canister. Hook the two latches onto the tabs on the sides of the dust cup and push down to lock.

CLEANING THE PRE-MOTOR FILTERS

- 1 Remove the dust cup.
- 2 Pull the 2 filters out from the top of the canister. **(Fig. 20)**
- 3 Rinse the filters thoroughly in lukewarm water until the water runs clear.

NOTE: The material in the filter will discolor over time. This is normal and will not affect the performance of the filter.

- 4 Squeeze out excess water and let air-dry for at least 24 hours before replacing. **DO NOT** use a hair dryer or other heating methods to dry.
- 5 Reinsert the felt filter first, then the foam filter.
- 6 Replace the dust cup.

MAINTENANCE - CONT'D

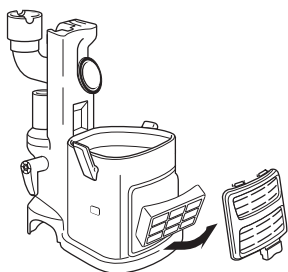

Fig. 21

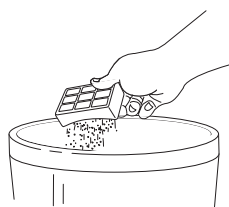

Fig. 22

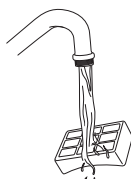

Fig. 23

CLEANING THE POST-MOTOR HEPA FILTER

- 1 Remove the filter cover from the front of the vacuum by lifting the tab to pull the cover away from the vacuum. (Fig. 21)
- 2 Pull the HEPA filter straight out.
- 3 Turn the filter over so that the dirty side is on the bottom. Tap it vigorously against the inside of a trash receptacle to knock off any dust. (Fig. 22)
- 4 With the dirty side down, rinse the HEPA filter with lukewarm tap water until the water runs clear. (Fig. 23)

NOTE: The material in the filter will discolor over time. This is normal and will not affect the performance of the filter.

- 5 Allow the filter to air-dry for 24 hours. **DO NOT** use a hair dryer or other heating methods to dry.
- 6 When the HEPA filter is completely dry, reinstall it.
- 7 Replace the cover by inserting the two tabs into the holes at the top and then swinging the cover down until it clicks into place.

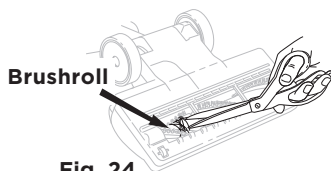

Fig. 24

CLEANING THE BRUSHROLL

When your brushroll needs cleaning or locks onto an object, it automatically shuts down. The indicator light will illuminate red, warning you to turn off the vacuum and clear the blockage immediately. The light will reset once the blockage has been cleared and power has been cycled on and off or the vacuum has been locked in the upright position.

- 1 Detach the motorized floor nozzle from the canister.
- 2 Inspect the airway and the brushroll. Remove any debris buildup. With scissors, carefully cut away any fibers or hair wrapped around the brushroll. Avoid damaging or cutting the bristles. (Fig. 24)

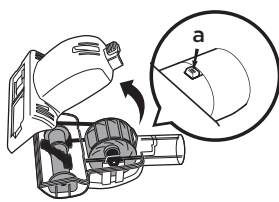

Fig. 25

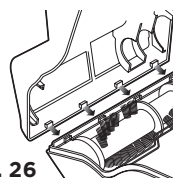

Fig. 26

CLEANING THE PET HAIR TOOL

- 1 Slide the locking latch (a) forward and lift off the brushroll housing. (Fig. 25)
- 2 Carefully remove any blockage or debris and use scissors to cut away any buildup of hair or string wrapped around the brushroll.
- 3 To reassemble, insert the tabs on the front edge of the brushroll housing into the matching holes in the top half and tilt it back down until it clicks into place. (Fig. 26)



Make sure you are working in a well-lit area and use a flashlight to help search for blockages.

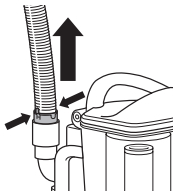

Fig. 27

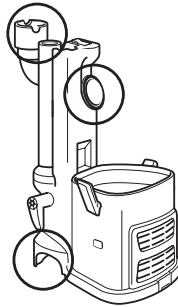

Fig. 28

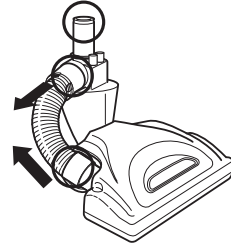

Fig. 29

CHECKING FOR BLOCKAGES

Blockages may cause your vacuum to overheat and shut down. To prevent this from happening, check potential blockage areas after heavy use, or if you detect a loss of suction or poor cleaning performance.

1 Dust Cup

Dust cup may be full. Empty dust cup.

2 Pre-Motor & Post-Motor Filters

Pre-motor filters require washing every 3 months for optimum performance. The post-motor HEPA filter needs to be washed every 2 years.

Ensure that all the filters are clean.

3 Accessories

- Check intake openings:
 - Wand
 - Dusting Brush
 - Crevice Tool
 - Pet Hair Tool

4 Hose and Connections to Vacuum

- Detach the stretch hose from the back of the canister by squeezing the tabs together and pulling up. **(Fig. 27)** Straighten out the hose and look inside for blockages.
- Remove the dust cup and wand and detach the canister from the motorized floor nozzle. Look in all 4 openings for any blockages. **(Fig. 28)**

5 Motorized Floor Nozzle

- Detach the hose on the motorized floor nozzle. Pull the bottom of the hose out of the connector, and release the top of the hose by squeezing the tabs together. Check the hose and the openings for blockages. **(Fig. 29)**

ORDERING ADDITIONAL PARTS

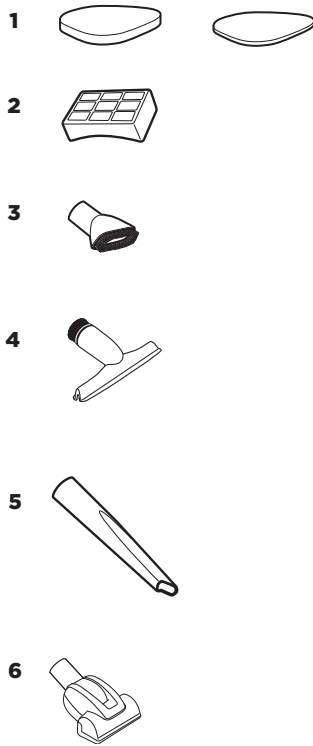

PART		PART NO.
1	Pre-Motor Filter Set	XFF350
2	HEPA Filter	XHF350
3	Dusting Brush	172FFJ
4	Pet Upholstery Tool	261FFJ46
5	8" Crevice Tool	173FFJ
6	Pet Hair Tool	119FFJ

To order additional parts or accessories go to sharkaccessories.com or contact Customer Service: 1-800-798-7398.

TROUBLESHOOTING GUIDE

PROBLEM	POSSIBLE REASONS & SOLUTIONS
<p>Vacuum is not picking up dirt.</p>	<p>Check filters to see if they need cleaning. Follow instructions for rinsing and drying the filters before reinserting back into the vacuum. (See Maintenance sections for instructions.)</p> <p>Dust cup may be full; empty dust cup.</p> <p>Check hose and hose connections for blockages; clear blockages if required.</p> <p>If dust cup is empty, and attachment inlets are clear, check for other blockages. (See Checking for Blockages for instructions.)</p>
<p>Vacuum lifts area rugs (lightweight, movable rugs).</p>	<p>Suction is powerful. Take care when vacuuming area rugs or rugs with delicately sewn edges. Rotate the suction release collar on the handle counterclockwise to decrease suction power.</p> <p>Move the selector switch to Setting I (Bare Floor) to disengage the brushroll</p>
<p>Airflow is restricted. No suction or light suction.</p>	<p>Check filters to see if they need cleaning. Follow instructions for rinsing and drying the filters before reinserting back into the vacuum. Dust cup may be full; empty dust cup.</p> <p>Check hose, hose connections, nozzles, and accessories for blockages; clear blockages if required.</p> <p>Rotate the suction release collar on the handle clockwise to increase suction power.</p> <p>If dust cup is empty, and attachment inlets are clear, check for other blockages.</p>
<p>Brushroll does not spin.</p>	<p>Immediately turn off and unplug vacuum, disconnect the nozzle, and remove any blockage before reconnecting and turning vacuum back on.</p> <p>Step lightly on the floor nozzle and tilt the handle back to engage the brushroll.</p> <p>Move the selector switch to Setting II (Brushroll).</p>
<p>Vacuum turns off on its own or indicator light flashes red.</p>	<p>This vacuum cleaner is equipped with a motor protective thermostat. If for some reason your vacuum overheats, the thermostat will automatically turn the unit off. Should this occur, perform the following steps to restart the motor thermostat:</p> <ol style="list-style-type: none"> 1. Move the selector switch to the Off position. 2. Unplug the vacuum. 3. Empty dust cup and clean filters. 4. Check for blockages in hose, accessories, and inlet openings. 5. Allow the unit to cool for a minimum of 45 minutes. 6. Plug in vacuum. 7. Move the selector switch to Setting I (Bare Floor) to restart the vacuum. <p>Note: If vacuum still does not start, contact Customer Service at: 1-800-798-7398.</p>

To purchase replacement parts, please visit sharkaccessories.com or contact Customer Service: 1-800-798-7398.

FIVE (5) YEAR LIMITED WARRANTY

The Five (5) Year Limited Warranty applies to purchases made from authorized retailers of **SharkNinja Operating LLC**. Warranty coverage applies to the original owner and to the original product only and is not transferable.

SharkNinja warrants that the unit shall be free from defects in material and workmanship for a period of five (5) years from the date of purchase when it is used under normal household conditions and maintained according to the requirements outlined in the Owner's Guide, subject to the following conditions and exclusions:

What is covered by this warranty?

1. The original unit and/or non-wearable components deemed defective, in SharkNinja's sole discretion, will be repaired or replaced up to five (5) years from the original purchase date.
2. In the event a replacement unit is issued, the warranty coverage ends six (6) months following the receipt date of the replacement unit or the remainder of the existing warranty, whichever is later. SharkNinja reserves the right to replace the unit with one of equal or greater value.

What is not covered by this warranty?

1. Normal wear and tear of wearable parts (such as foam filters, HEPA filters, pads, etc.), which require regular maintenance and/or replacement to ensure the proper functioning of your unit, are not covered by this warranty. Replacement parts are available for purchase at sharkaccessories.com.
2. Any unit that has been tampered with or used for commercial purposes.
3. Damage caused by misuse (e.g., vacuuming up water or other liquids), abuse, negligent handling, failure to perform required maintenance (e.g., not cleaning the filters), or damage due to mishandling in transit.
4. Consequential and incidental damages.
5. Defects caused by repair persons not authorized by SharkNinja. These defects include damages caused in the process of shipping, altering, or repairing the SharkNinja product (or any of its parts) when the repair is performed by a repair person not authorized by SharkNinja.
6. Products purchased, used, or operated outside North America.

How to get service

If your appliance fails to operate properly while in use under normal household conditions within the warranty period, visit sharkclean.com/support for product care and maintenance self-help. Our Customer Service Specialists are also available at **1-800-798-7398** to assist with product support and warranty service options, including the possibility of upgrading to our VIP warranty service options for select product categories.

SharkNinja will cover the cost for the customer to send in the unit to us for repair or replacement. A fee of \$24.95 (subject to change) will be charged when SharkNinja ships the repaired or replacement unit.

How to initiate a warranty claim

You must call **1-800-798-7398** to initiate a warranty claim. You will need the receipt as proof of purchase. A Customer Service Specialist will provide you with return and packing instruction information.

How state law applies

This warranty gives you specific legal rights, and you also may have other rights that vary from state to state. Some states do not permit the exclusion or limitation of incidental or consequential damages, so the above may not apply to you.

Product Registration

Please visit registryourshark.com or call **1-800-798-7398** to register your new Shark® product within ten (10) days of purchase. You will be asked to provide the store name, date of purchase and model number along with your name and address.

The registration will enable us to contact you in the unlikely event of a product safety notification. By registering you acknowledge to have read and understood the instructions for use, and warnings set forth in the accompanying instructions.

NOTES

PLEASE READ CAREFULLY AND KEEP FOR FUTURE REFERENCE.

This Owner's Guide is designed to help you get a complete understanding of your new Shark® Lift-Away® XL.

SharkNinja Operating LLC
US: Needham, MA 02494
CAN: Ville St-Laurent, QC H4S 1A7
1-800-798-7398
sharkclean.com

Illustrations may differ from actual product. We are constantly striving to improve our products; therefore the specifications contained herein are subject to change without notice.

For SharkNinja U.S. Patent information, visit www.sharkninja.com/USPatents

© 2019 SharkNinja Operating LLC. LIFT-AWAY, POWERED LIFT-AWAY, SHARK, and SHARK NAVIGATOR are registered trademarks of SharkNinja Operating LLC. NAVIGATOR and ZERO-M are trademarks of SharkNinja Operating LLC.

UV550_SERIES_IB_Rev_Mv11
PRINTED IN CHINA



@sharkcleaning