







9606-PLR  
Tub/Shower/Hand Shower System  
**Operation & Maintenance Manual**



Model Numbers	Specification
<input type="checkbox"/> <b>9606-PLR</b> <i>Origins Tub/Shower/Hand Shower System</i>	<p>Tub/shower/hand shower system powered by the Temptrol<sup>®</sup> Pressure Balancing valve. Features adjustable stop screw to limit handle turn, 36" slide bar, separate three function diverter, non-diverter tub spout, in-line vacuum breaker, 60" flexible metal hose, ADA hand shower, 1 mode showerhead with easy to clean rubber nozzles and standard 2.5 gpm (9.5 L/min) flow restrictors. Components made from metal and nonmetallic materials plated in standard polished chrome finish.</p> <div style="text-align: right;">   </div>
<p><b>Modifications</b></p> <ul style="list-style-type: none"> <li><input type="checkbox"/> <b>-1.5</b>  1.5 gpm (5.7 L/min) flow restrictor</li> <li><input type="checkbox"/> <b>-2.0</b>  2.0 gpm (7.6 L/min) flow restrictor</li> <li><input type="checkbox"/> <b>-231</b> Super showerhead in place of Clear-Flo</li> <li><input type="checkbox"/> <b>-295</b> Institutional showerhead in place of Clear-Flo</li> <li><input type="checkbox"/> <b>-SS</b> Slip spout on any tub/shower unit</li> <li><input type="checkbox"/> <b>-X</b> Integral service stops</li> <li><input type="checkbox"/> <b>-CHKS</b> Integral check stops</li> <li><input type="checkbox"/> <b>-IPS</b> 1/2" female IPS connections</li> <li><input type="checkbox"/> <b>-REV</b> Reverse coring for back to back installations</li> <li><input type="checkbox"/> <b>-LP</b> Loop handle</li> <li><input type="checkbox"/> <b>-B</b> Chrome brass escutcheon</li> <li><input type="checkbox"/> <b>-D</b> Chrome brass dome cover</li> <li><input type="checkbox"/> <b>-VP</b> Vandal proof escutcheon screws</li> <li><input type="checkbox"/> <b>-QD</b> Quick disconnect on hand shower units</li> <li><input type="checkbox"/> <b>-R</b> White vinyl hose in place of metal hose</li> <li><input type="checkbox"/> <b>-VB</b> Elevated vacuum breaker</li> <li><input type="checkbox"/> <b>-OP</b> 13" oval plate</li> <li><input type="checkbox"/> <b>-L/HD</b> Less showerhead</li> <li><input type="checkbox"/> <b>-72</b> 6' hose in place of 5' standard</li> <li><input type="checkbox"/> <b>-B30</b> 30" adjusting bar in place of standard 36" bar</li> <li><input type="checkbox"/> <b>-B48</b> 48" adjusting bar in place of standard 36" bar</li> <li><input type="checkbox"/> <b>-L/GB</b> Less grab bar</li> <li><input type="checkbox"/> <b>-T24</b> 24" grab bar in place of standard 36" bar</li> <li><input type="checkbox"/> <b>-TRM</b> Trim only, valve not included</li> <li><input type="checkbox"/> <b>-STN</b> Satin Nickel finish</li> </ul> <p><b>Note:</b> Append appropriate -suffix to model number.</p>	
	<p><b>Compliance</b></p>
<p>-ASME A112.18.1/CSA B125.1 -WaterSense 1.5 gpm (5.7 L/min) 2.0 gpm (7.6 L/min)</p> <p>For California Residents <b>WARNING:</b> This product contains chemicals known to the State of California to cause cancer, birth defects, or other reproductive harm.</p>	<div style="text-align: right;">   </div>
	<p><b>Warranty</b></p>
<p><b>Limited Lifetime</b> - to the original end purchaser in consumer/residential installations. <b>5 Years</b> - for industrial/commercial installations. Refer to <a href="http://www.symmons.com/warranty">www.symmons.com/warranty</a> for complete warranty information.</p>	

## Dimensions

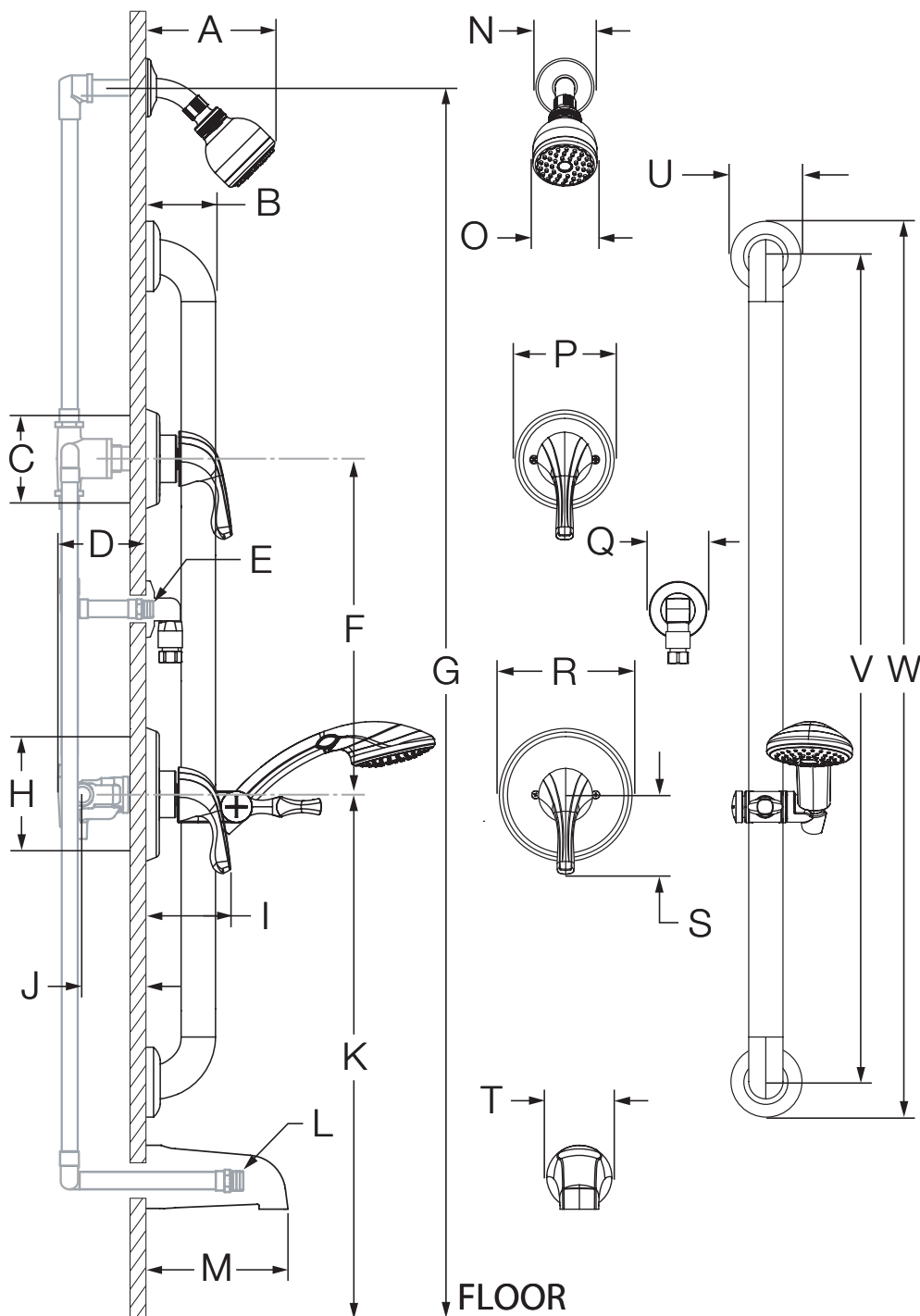

Measurements	
A	6 3/8", 162 mm
B	3", 76 mm
C	Diverter Valve Hole Size Min. Ø 3", 76 mm Max. Ø 3 1/4", 83 mm
D	3 1/2", 89 mm
E	Male 1/2" NPT fitting must protrude 3/8" from finished wall
F	Ref. 10", 254 mm
G	Ref. 77", 1956 mm
H	Shower Valve Hole Size Min. Ø 3", 76 mm Max. Ø 4", 102 mm
I	3 5/8", 92 mm
J	Rough-in 2 3/8" ± 1/2", 60 mm ± 13 mm
K	Ref. 32", 813 mm
L	Male 1/2" NPT fitting must protrude 4" from finished wall
M	5 1/2", 140 mm
N	Ø 2 1/2", 64 mm
O	Ø 2 3/4", 70 mm
P	Ø 4 1/4", 108 mm
Q	Ø 2 1/2", 64 mm
R	Ø 5 3/4", 146 mm
S	3 3/8", 86 mm
T	Ø 2 1/2", 64 mm
U	Ø 3 1/8", 79 mm
V	36", 914 mm
W	39", 991 mm

### Notes:

- 1) All dimensions measured from nominal rough-in (see J as reference).
- 2) Dimensions subject to change without notice.

## Parts Breakdown

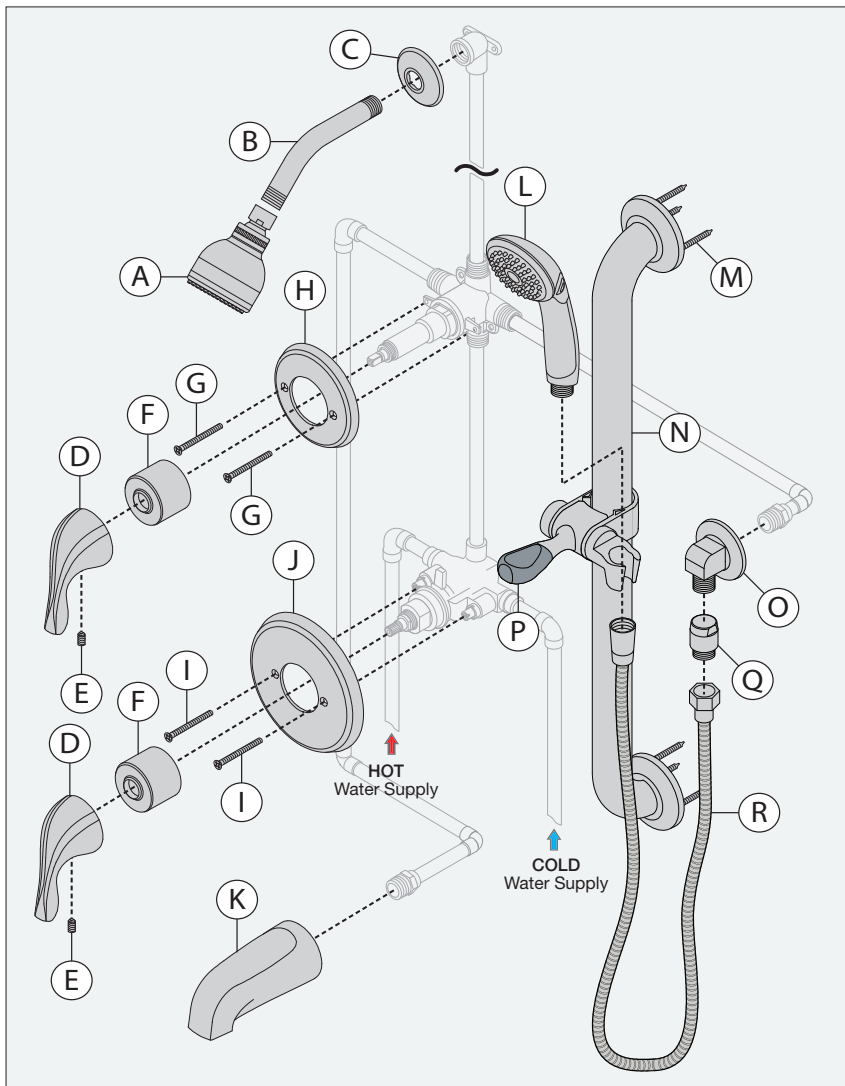

### Notes:



- 1) Apply a bead of silicone around the perimeter of all shower trim installed flush to the finished wall. Leave opening on bottom of escutcheons for weep hole.
- 2) Apply plumber tape to all threaded connections.
- 3) Escutcheon artwork is dependent on handle style.

## Replacement Parts

Item	Description	Part Number
A	Showerhead	4-141*
B C	Shower Arm & Flange	300S*
D E	Shower or Diverter Handle Assembly	RTS-063*
F	Dome Cover	T-19*
G H	Diverter Escutcheon Kit	96-66-DIV-ESC*
I J	Shower Escutcheon Kit	Standard 9600-PLR-ESC* Brass 9600-PLR-B-ESC*
K	Tub Spout	060*
L	Hand Shower	ADACHS*
O	Wall Ell	40A*
Q R	In-line Vacuum Breaker & 60" Hose	SP-4*

**\*Note:** Append -STN to part number for Satin Nickel finish.

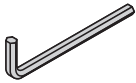
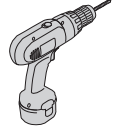
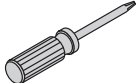
## Tools Required

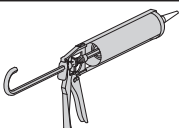
Adjustable wrench	
Allen wrench (1/8")	
Drill	
Phillips head screwdriver	
Plumber tape	
Silicone	

## Installation

### Note:

For valve body installation, please see valve body manuals.

- 1) Install shower escutcheon (J) to shower valve. Secure with two screws (I).

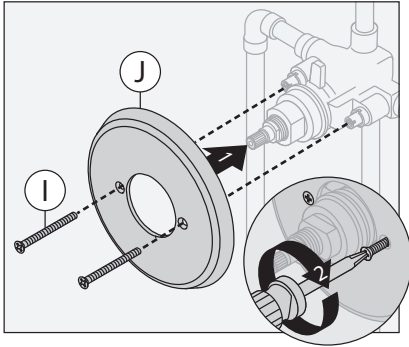

- 2) Install diverter escutcheon (H) to diverter valve. Secure with two screws (G).

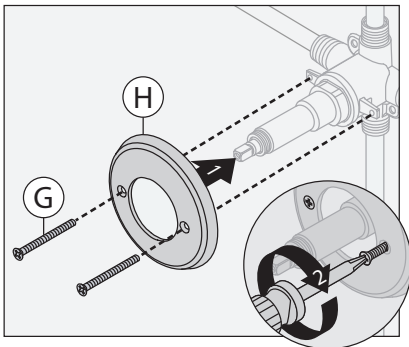

- 3) Install dome covers (F) to valves. Turn clockwise to secure.

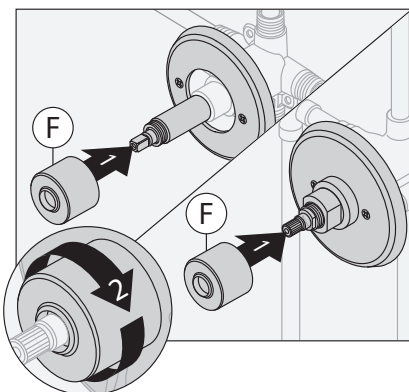

- 4) Install handles (D) to valves. Secure with set screws (E).

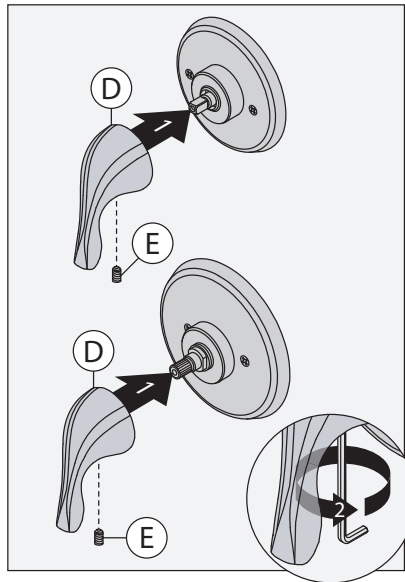

**Note:** Handles should be facing the 6 o'clock position.

- 5) Install tub spout (K) to pipe fitting. Turn clockwise to secure.

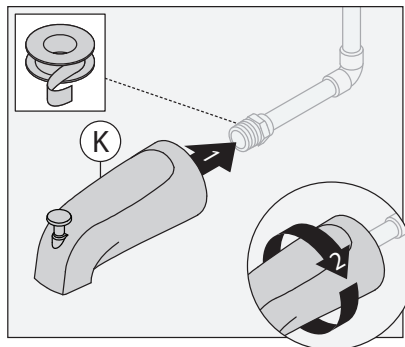

- 6) Attach shower arm (B) and flange (C) to vertical shower pipe. Turn clockwise to tighten.

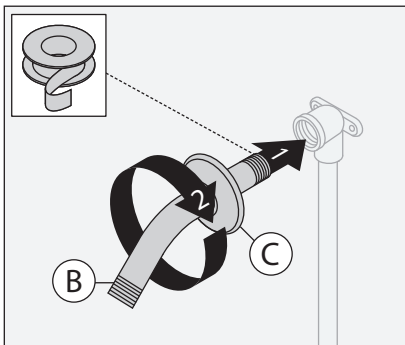

- 7) Install showerhead (A) to shower arm (B). Turn clockwise to tighten.

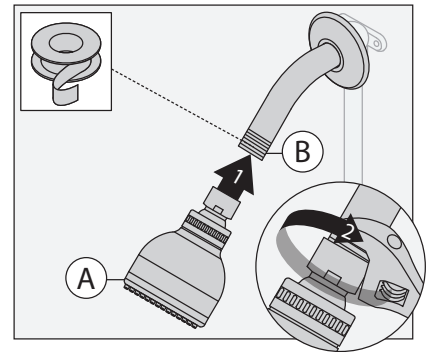

- 8) Remove slide bar ends (N1) from slide bar flanges. Using flanges as a guide, drill 1/8" pilot holes into studs or wood blocking. With slide bar (N) in position, secure to wall using screws (M). Attach slide bar ends (N1) to bar flanges.

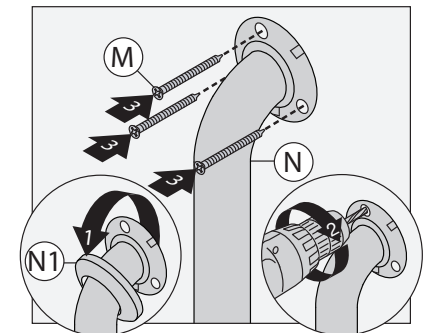

**Note:** Slide bar must be secured with at least two of the three screws (M) at each end.

- 9) Disassemble slide assembly (P).

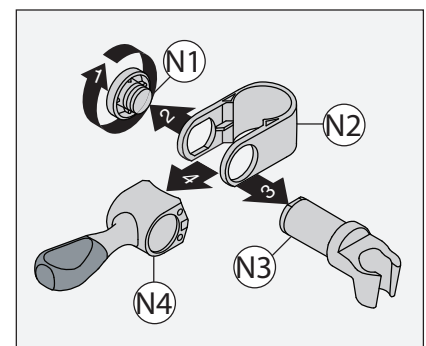

## Installation

10) Install slide assembly (P) to slide bar (N). Flat edge on (P2) and (P3) must be aligned. Arrows on (P2) and (P4) indicate bottom side.

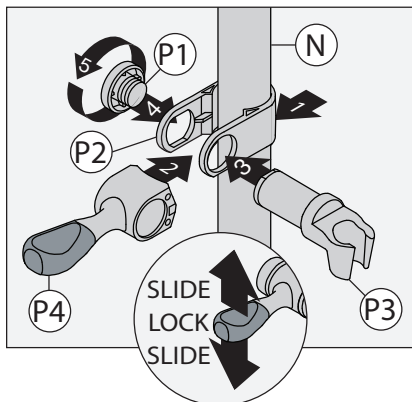

**Note:** Adjust screw cap (P1) for ease of movement of slide assembly.

11) Press tabs on wall ell flange and install wall ell (O) to pipe fitting. Turn clockwise to secure.

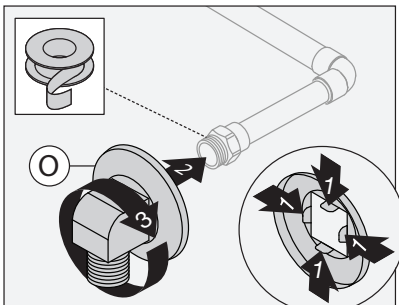

12) Attach hand shower (L) to hose (R). Attach hose (R) to vacuum breaker (Q). Connect vacuum breaker (Q) to wall ell (O). Turn clockwise to tighten.

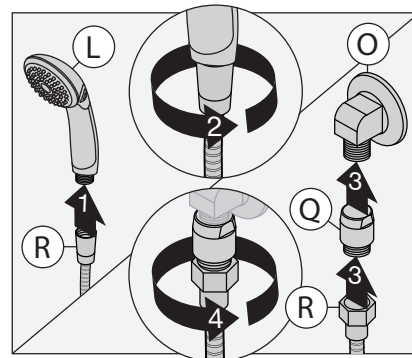

## Operation (Temperature Control)

1) Turn shower handle counterclockwise approximately 1/4 turn to put valve in cold position.

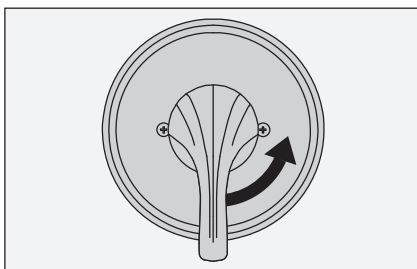

2) Turn shower handle counterclockwise approximately 1/2 turn to put valve in warm position.

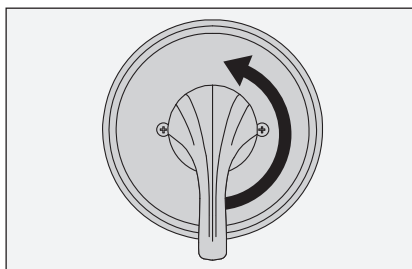

3) Turn shower handle counterclockwise approximately 3/4 turn to put valve in hot position.

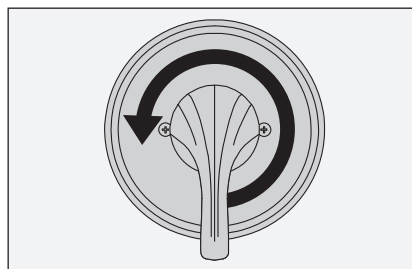

## Operation (Diverter Control)

1) Cartridge is factory set to divert to function 1.

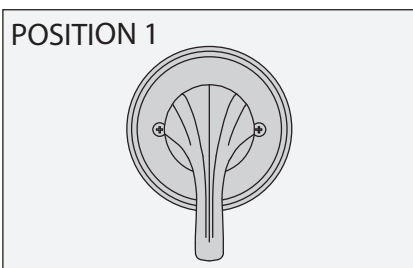

2) Turn handle to position 2 to share functions 1 and 3.

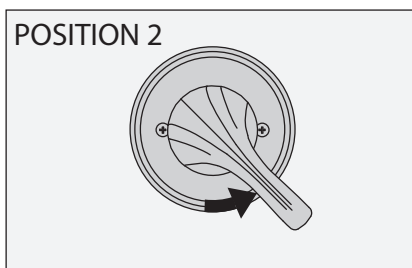

3) Turn handle to position 3 to divert to function 3.

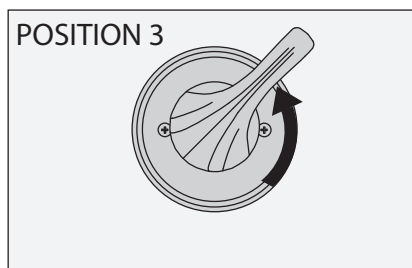

**Operation (Diverter Control cont'd.)**

4) Turn handle to position 4 to share functions 2 and 3.

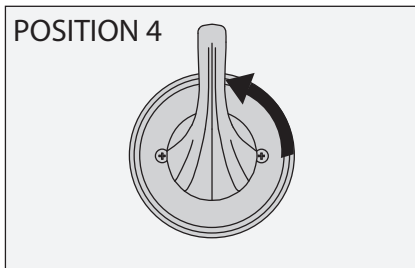

5) Turn handle to position 5 to divert to function 2.

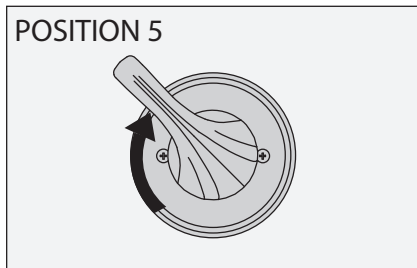

6) Turn handle to position 6 to share functions 1 and 2.

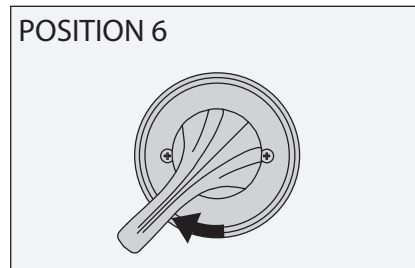

**Troubleshooting Chart**







Problem	Cause	Solution
Finish is spotting.	Elements in water supply may cause water staining on finish.	Clean finished trim area with a soft cloth using mild soap and water or a non-abrasive cleaner and then quickly rinse with water.

9606-PLR

Sistema de bañera/ducha/ducha de mano

**Manual de funcionamiento y mantenimiento**



Números de modelo	Especificación
<input type="checkbox"/> <b>9606-PLR</b> <i>Sistema de bañera/ducha/ducha de mano Origins</i>	<p>Sistema para bañera/ducha/ducha de mano con válvula compensadora de presión Temptrol<sup>®</sup>. Incluye un tornillo con tope ajustable para limitar el giro de la manija, barra deslizadora de 36", desviador separado de tres funciones, surtidor de bañera sin desviador, igualador de presión integrado, manguera metálica flexible de 60", ducha de mano ADA, cabezal de ducha de 1 función con boquillas de goma fáciles de limpiar y reductores de caudal estándar de 2.5 gpm (9.5 L/min). Los componentes están hechos de materiales metálicos y no metálicos recubiertos con un acabado en cromo pulido estándar.</p> <div style="text-align: right;">   </div>
<p><b>Modificaciones</b></p> <ul style="list-style-type: none"> <li><input type="checkbox"/> <b>-1.5</b>  Reductor de caudal de 1.5 gpm (5.7 L/min)</li> <li><input type="checkbox"/> <b>-2.0</b>  Reductor de caudal de 2.0 gpm (7.6 L/min)</li> <li><input type="checkbox"/> <b>-231</b> Cabezal de ducha Super en lugar de Clear-Flo</li> <li><input type="checkbox"/> <b>-295</b> Cabezal de ducha Institucional en lugar de Clear-Flo</li> <li><input type="checkbox"/> <b>-SS</b> Surtidor de montaje deslizante en cualquiera de las unidades para bañera y ducha</li> <li><input type="checkbox"/> <b>-X</b> Llaves de paso integradas</li> <li><input type="checkbox"/> <b>-CHKS</b> Válvulas de retención integradas</li> <li><input type="checkbox"/> <b>-IPS</b> Salida de unión hembra de 1/2" I.P.S.</li> <li><input type="checkbox"/> <b>-REV</b> Conexión inversa para instalaciones encontradas</li> <li><input type="checkbox"/> <b>-LP</b> Manija en bucle</li> <li><input type="checkbox"/> <b>-B</b> Placa decorativa de latón cromado</li> <li><input type="checkbox"/> <b>-D</b> Cubierta del domo de latón cromado</li> <li><input type="checkbox"/> <b>-VP</b> Tornillos para placa decorativa a prueba de vandalismo</li> <li><input type="checkbox"/> <b>-QD</b> Desconexión rápida en unidades de ducha de mano</li> <li><input type="checkbox"/> <b>-R</b> Manguera de vinilo blanco en lugar de la manguera de metal</li> <li><input type="checkbox"/> <b>-VB</b> Igualador de presión elevado</li> <li><input type="checkbox"/> <b>-OP</b> Placa ovalada de 13"</li> <li><input type="checkbox"/> <b>-L/HD</b> Sin el cabezal de ducha</li> <li><input type="checkbox"/> <b>-72</b> Manguera de 6 pies en vez de la estándar de 5 pies</li> <li><input type="checkbox"/> <b>-B30</b> Barra de ajuste de 30" en lugar de barra estándar de 36"</li> <li><input type="checkbox"/> <b>-B48</b> Barra de ajuste de 48" en lugar de barra estándar de 36"</li> <li><input type="checkbox"/> <b>-L/GB</b> Menos barra de sujeción</li> <li><input type="checkbox"/> <b>-T24</b> Barra de sujeción de 24" en lugar de barra estándar de 36"</li> <li><input type="checkbox"/> <b>-TRM</b> Borde solamente, válvula no incluida</li> <li><input type="checkbox"/> <b>-STN</b> Acabado de níquel satinado</li> </ul> <p><b>Nota:</b> Anexar el -sufijo apropiado al número de modelo.</p>	
	<p><b>Cumplimiento</b></p> <p>-ASME A112.18.1/CSA B125.1 -WaterSense 1.5 gpm (5.7 l/min) 2.0 gpm (7.6 L/min)</p> <div style="text-align: right;">   </div>
	<p><b>Garantía</b></p> <p><b>Vida útil limitada</b> - al comprador final original en instalaciones del consumidor/residenciales. <b>5 años</b> - para instalaciones industriales y comerciales. Consulte <a href="http://www.symmons.com/warranty">www.symmons.com/warranty</a> para obtener información completa sobre la garantía.</p>



## Dimensiones

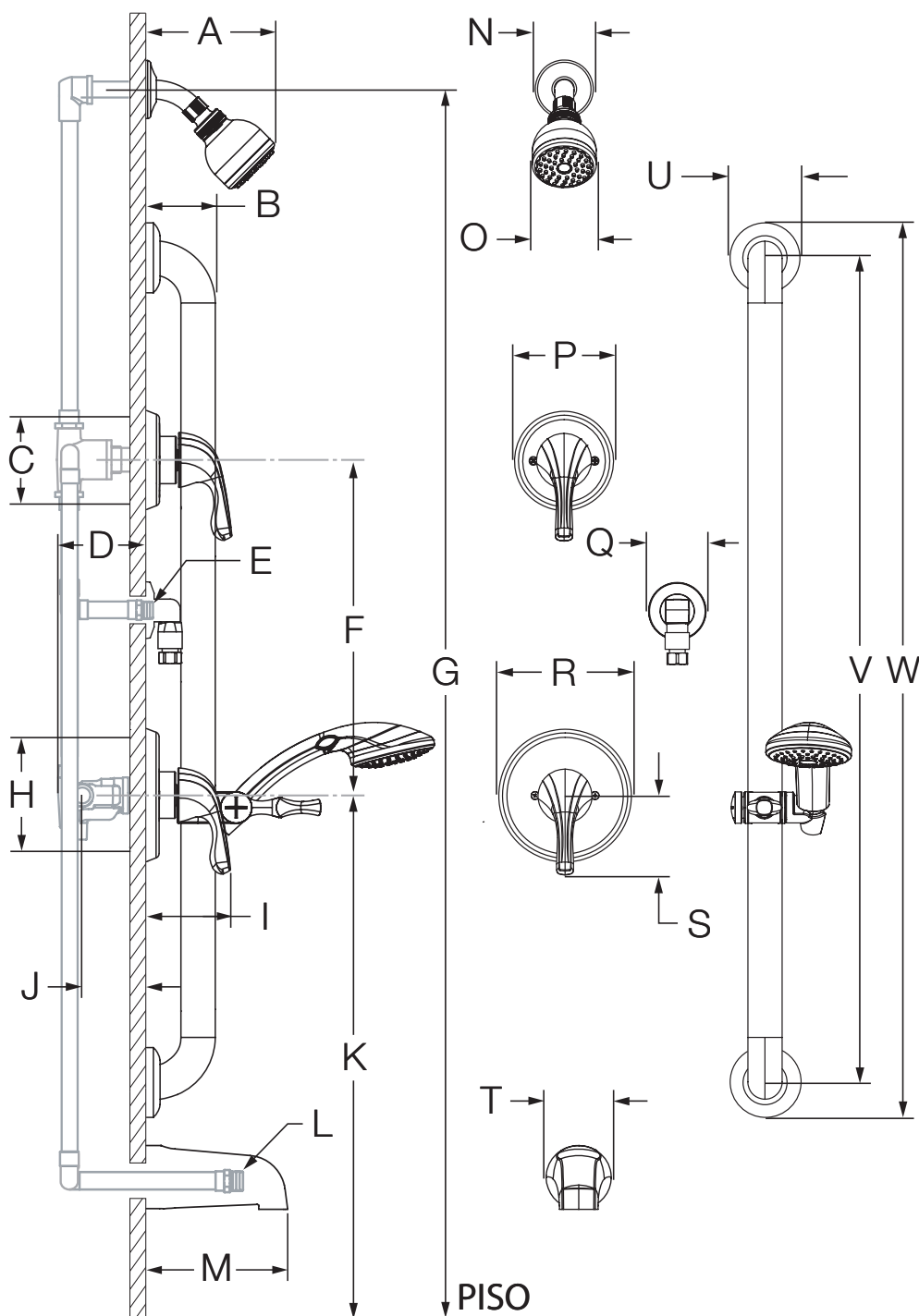

Medidas	
A	6 3/8", 162 mm
B	3", 76 mm
C	Tamaño de los orificios de la válvula de desvío Mín. Ø 3", 76 mm Máx. Ø 3 1/4", 83 mm
D	3 1/2", 89 mm
E	La rosca macho NPT de 1/2" debe sobresalir 3/8" de la pared terminada
F	Ref. 10", 254 mm
G	Ref. 77", 1956 mm
H	Tamaño de los orificios de la válvula para ducha Mín. Ø 3", 76 mm Máx. Ø 4", 102 mm
I	3 5/8", 92 mm
J	Empotrado 2 3/8" ± 1/2", 60 mm ± 13 mm
K	Ref. 32", 813 mm
L	La rosca macho NPT de 1/2" debe sobresalir 4" de la pared terminada
M	5 1/2", 140 mm
N	Ø 2 1/2", 64 mm
O	Ø 2 3/4", 70 mm
P	Ø 4 1/4", 108 mm
Q	Ø 2 1/2", 64 mm
R	Ø 5 3/4", 146 mm
S	3 3/8", 86 mm
T	Ø 2 1/2", 64 mm
U	Ø 3 1/8", 79 mm
V	36", 914 mm
W	39", 991 mm

### Notas:

- 1) Todas las dimensiones tomadas desde el empotrado (ver J para referencia).
- 2) Las dimensiones están sujetas a cambios sin previo aviso.



## Desglose de piezas

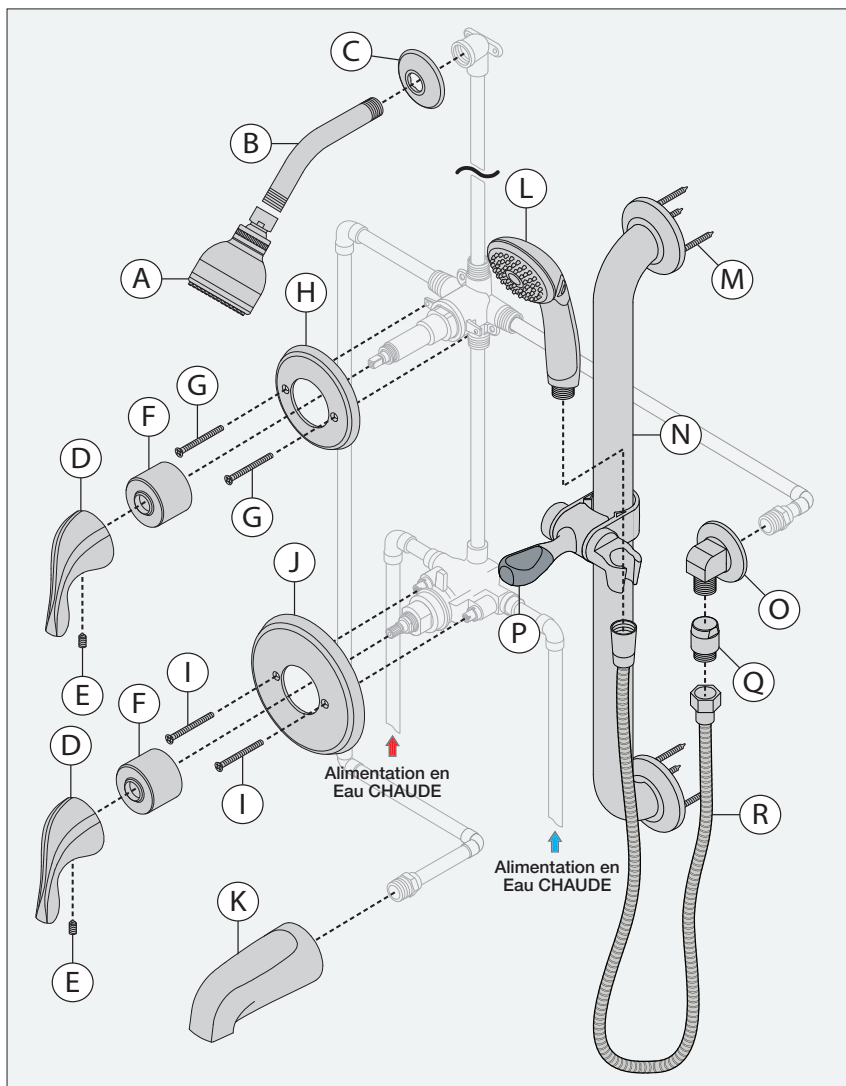

### Notas:

- 1) Aplique una gota de silicona alrededor del perímetro del borde de la ducha a nivel de la pared terminada. Deje un orificio en la parte inferior de la placa para drenar la humedad.
- 2) Coloque cinta de teflón en todas las salidas de unión roscadas.
- 3) El diseño de la placa decorativa depende del tipo de manija.

## Repuestos

Artículo	Descripción	Número de pieza
A	Cabezal de ducha	4-141*
B	Brazo de la ducha y brida	300S*
C		
D	Conjunto de manija de ducha o desviador	RTS-063*
E		
F	Cubierta del domo	T-19*
G	Kit de placa decorativa del desviador	96-66-DIV-ESC*
H		
I	Kit de placa decorativa para la ducha	<b>Estándar</b> 9600-PLR-ESC*
J		<b>Latón</b> 9600-PLR-B-ESC*
K	Surtidor para bañera	060*
L	Ducha de mano	ADACHS*
O	Codo de pared	40A*
Q	Igualador de presión integrado y manguera de 60"	SP-4*
R		

**\*Nota:** Anexar -STN al número de pieza para acabado de níquel satinado.

## Herramientas requeridas

Llave inglesa	
Llave Allen (1/8")	
Taladro	
Destornillador phillips	
Cinta de teflón	
Silicona	

## Instalación

### Nota:

Para instalar el cuerpo de la válvula, vea el manual de la válvula.

- 1) Instale la placa decorativa de la ducha (J) en la válvula de la ducha. Sujételo con dos tornillos (I).

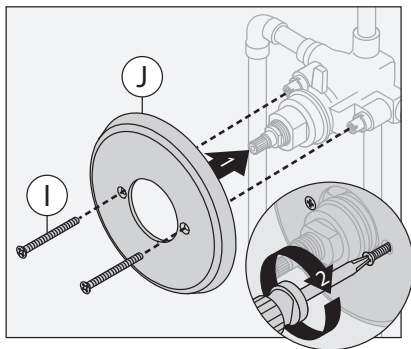

- 2) Instale la placa decorativa del desviador (H) en la válvula de desvío. Sujete con dos tornillos (G).

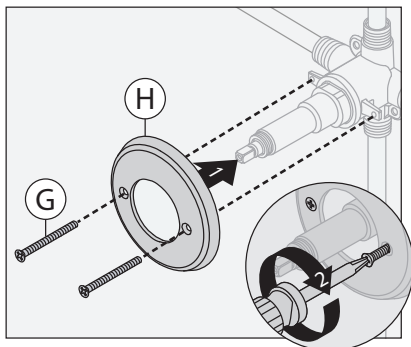

- 3) Instale las cubiertas de domo (F) en las válvulas. Gire en el sentido de las manecillas del reloj para apretar.

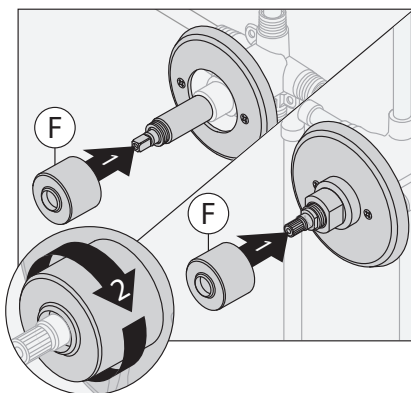

- 4) Instale las manijas (D) en las válvulas. Sujételas con los tornillos (E).

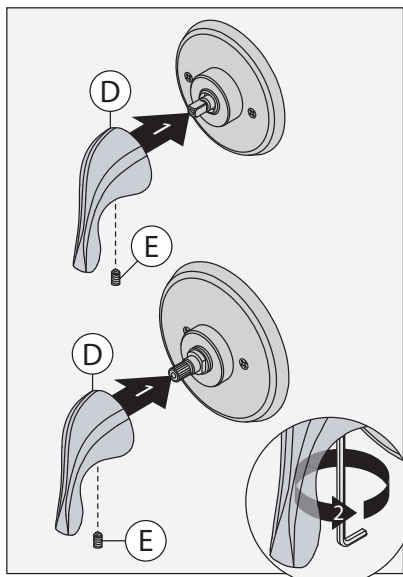

**Nota:** Las manijas deben situarse en la posición de las 6 en punto.

- 5) Instale el surtidor para la bañera (K) a la conexión de la tubería. Gire en el sentido de las manecillas del reloj para apretar.

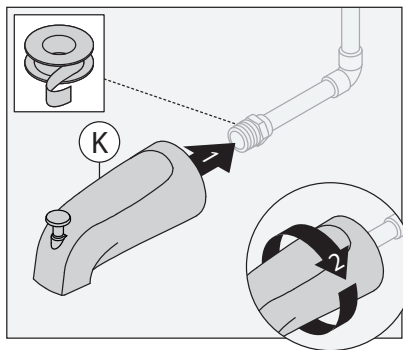

- 6) Una el brazo de la ducha (B) y la brida (C) al tubo vertical de la ducha. Gire en el sentido de las manecillas del reloj para apretar.

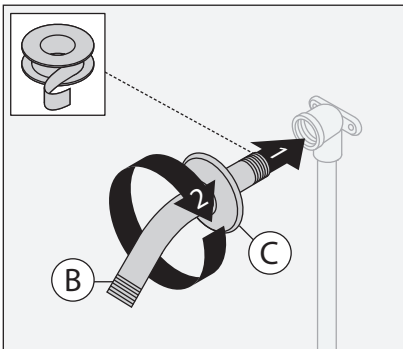

- 7) Instale el cabezal de ducha (A) al brazo de la ducha (B). Gire en el sentido de las manecillas del reloj para apretar.

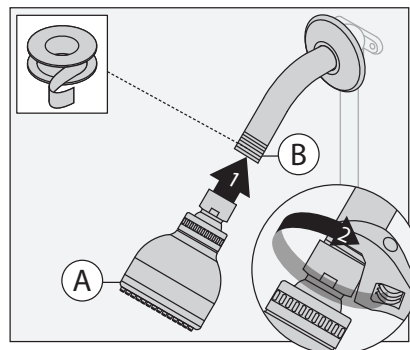

- 8) Quite los extremos de la la barra deslizadora (N1) de las bridas de la barra. Usando las bridas como guía, taladre agujeros guía de 1/8" en las vigas o bloques de madera. Con la barra deslizadora (N) en su posición, sujétela a la pared con tornillos (M). Coloque los extremos de la la barra deslizadora (N1) en las bridas de la barra.

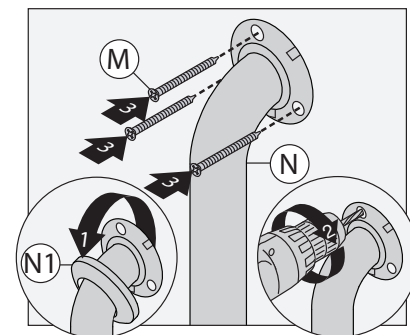

**Nota:** La barra deslizadora debe quedar sujeta al menos con dos de los tres tornillos (M) en cada extremo.

- 9) Desarme el conjunto de deslizador (P).

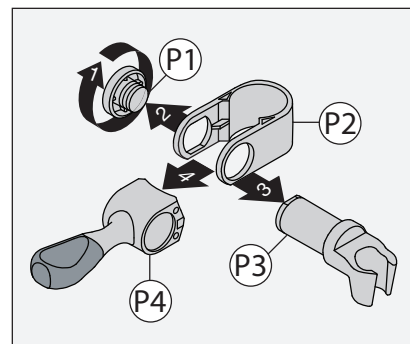

## Instalación

- 10) Instale el conjunto de deslizador (P) en la barra deslizadora (N). Los bordes planos de (P2) y (P3) deben quedar alineados. Las flechas en (P2) y (P4) señalan el lado inferior.

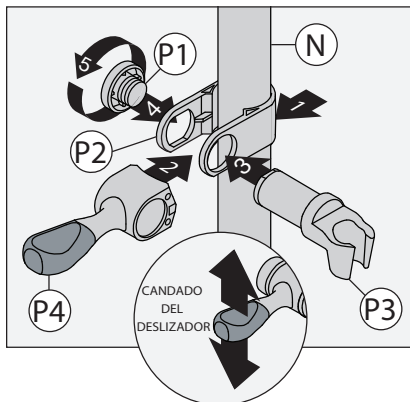

**Nota:** Ajuste la tapa del tornillo (P1) para facilitar el movimiento del conjunto de deslizador.

- 11) Presione las pestañas en la brida del codo de pared e instale el codo de pared (O) en el conector de la tubería. Gire en el sentido de las manecillas del reloj para apretar.

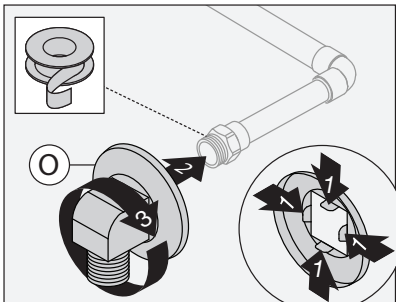

- 12) Conecte la ducha de mano (L) con la manguera (R). Conecte la manguera (R) con el igualador de presión (Q). Conecte el igualador de presión (Q) con el codo de pared (O). Gire en el sentido de las manecillas del reloj para apretar.

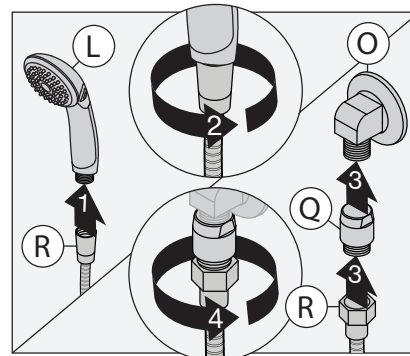

## Funcionamiento (Control de temperatura)

- 1) Gire el mango de la ducha 1/4 de vuelta en sentido contrario a las agujas del reloj para colocar la válvula en la posición de agua fría.

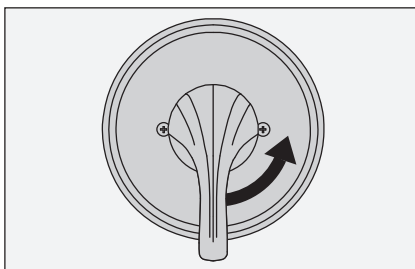

- 2) Gire el mango de la ducha 1/2 vuelta en sentido contrario a las agujas del reloj para colocar la válvula en la posición de agua tibia.

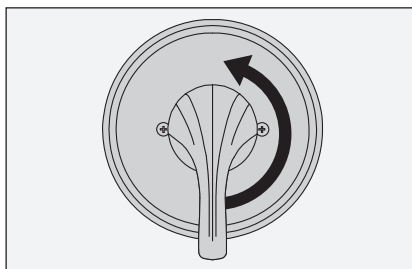

- 3) Gire el mango de la ducha 3/4 de vuelta en sentido contrario a las agujas del reloj para colocar la válvula en la posición de agua caliente.

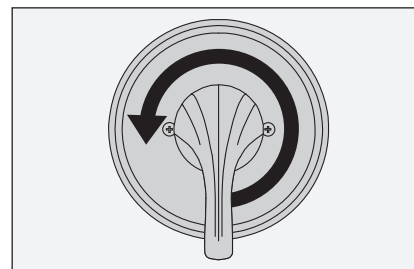

## Funcionamiento (Control de desviador)

- 1) El cartucho viene preconfigurado para desvío a la función 1.

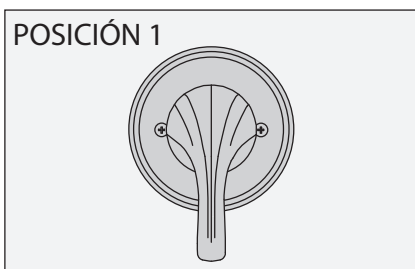

- 2) Gire la manija a la posición 2 para compartir las funciones 1 y 3.

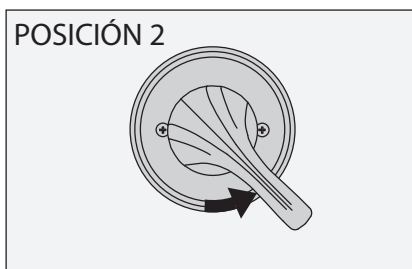

- 3) Gire la manija a la posición 3 para desviar a la función 3.

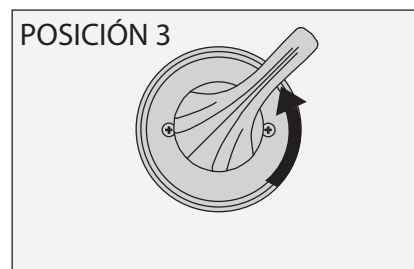

## Funcionamiento (Control de desviador)

4) Gire la manija a la posición 4 para compartir las funciones 2 y 3.

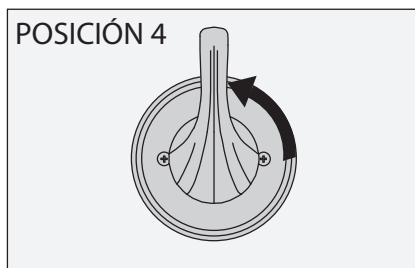

5) Gire la manija a la posición 5 para desviar a la función 2.

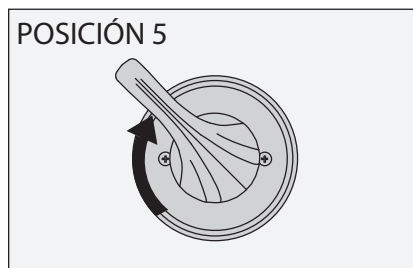

6) Gire la manija a la posición 6 para compartir las funciones 1 y 2.

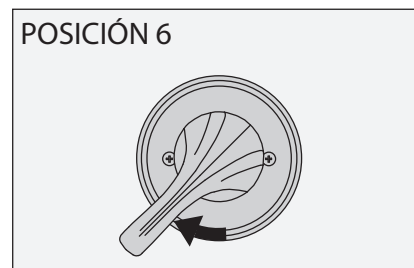

## Tabla de resolución de problemas







Problema	Causa	Solución
El acabado se está manchando.	Las partículas en el suministro de agua pueden provocar que el agua manche el acabado.	Limpie el área con acabado con un paño suave, usando jabón suave y agua o un limpiador no abrasivo, y luego enjuague rápidamente con agua.

9606-PLR

Système de douche/douche à main/baignoire

**Manuel d'utilisation et d'entretien**



Numéros de modèle	Spécifications
<input type="checkbox"/> <b>9606-PLR</b> <i>Système de douche/douche à main/baignoire Origins</i>	<p>Système de douche/douche à main/baignoire alimenté par la vanne à pression autorégularisée Temptrol®. Comprend la vis d'arrêt réglable pour limiter le tournage de la poignée, une barre à glissière de 36 po, un organe de dérivation séparé à trois fonctions, le bec de baignoire non-déviateur, le brise-vide en ligne, un tuyau de métal flexible de 60 po, une douche à main ADA, une pomme de douche à 1 mode avec des embouts en caoutchouc faciles à nettoyer et des réducteurs de débit de 2,5 gpm (9,5 L/min) standard. Les composants sont faits de matériaux métalliques et non métalliques au fini chrome poli standard.</p> <div style="text-align: right;">   </div>
<p><b>Modifications</b></p>	
<ul style="list-style-type: none"> <li><input type="checkbox"/> <b>-1.5</b>  Réducteur de débit de 1,5 gpm (5,7 L/min)</li> <li><input type="checkbox"/> <b>-2.0</b>  Réducteur de débit de 2,0 gpm (7,6 L/min)</li> <li><input type="checkbox"/> <b>-231</b> Super pomme de douche au lieu du Clear-Flo</li> <li><input type="checkbox"/> <b>-295</b> Pomme de douche institutionnelle au lieu du Clear-Flo</li> <li><input type="checkbox"/> <b>-SS</b> Bec de baignoire à enfiler sur toute unité de baignoire-douche</li> <li><input type="checkbox"/> <b>-X</b> Robinet d'interruption du service</li> <li><input type="checkbox"/> <b>-CHKS</b> Valve d'arrêt intégrée</li> <li><input type="checkbox"/> <b>-IPS</b> Raccords IPS femelles de 1/2 po</li> <li><input type="checkbox"/> <b>-REV</b> Corps central inversé pour installations dos à dos</li> <li><input type="checkbox"/> <b>-LP</b> Poignée en boucle</li> <li><input type="checkbox"/> <b>-B</b> Rosace chrome laiton</li> <li><input type="checkbox"/> <b>-D</b> Couvercle en dôme chrome laiton</li> <li><input type="checkbox"/> <b>-VP</b> Vis de rosace résistant au vandalisme</li> <li><input type="checkbox"/> <b>-QD</b> Débranchement rapide sur les unités de douche à main</li> <li><input type="checkbox"/> <b>-R</b> Tuyau de vinyle blanc au lieu du tuyau de métal</li> <li><input type="checkbox"/> <b>-VB</b> Brise-vide surélevé</li> <li><input type="checkbox"/> <b>-OP</b> Plaque ovale de 13 po</li> <li><input type="checkbox"/> <b>-L/HD</b> Sans pomme de douche</li> <li><input type="checkbox"/> <b>-72</b> Boyau de 6 pieds au lieu du boyau standard de 5 pieds</li> <li><input type="checkbox"/> <b>-B30</b> Réglage barre 30 po à la place de la barre standard</li> <li><input type="checkbox"/> <b>-B48</b> Réglage barre 48 po à la place de la barre standard</li> <li><input type="checkbox"/> <b>-L/GB</b> Aucune barre d'appui</li> <li><input type="checkbox"/> <b>-T24</b> Barre d'appui 24 po à la place de la barre standard</li> <li><input type="checkbox"/> <b>-TRM</b> Garniture seulement, vanne non incluse</li> <li><input type="checkbox"/> <b>-STN</b> Fini nickel satiné</li> </ul>	<p><b>Conformité</b></p> <p>-ASME A112.18.1/CSA B125.1 -WaterSense 1,5 gpm (5,7 L/min) 2,0 gpm (7,6 L/min)</p> <div style="text-align: right;">   </div>
<p><b>Remarque :</b> Juxtaposer le -suffixe approprié au numéro de modèle.</p>	<p><b>Garantie</b></p> <p><b>À vie limitée</b> – à l'acheteur original dans les installations du consommateur ou résidentielles. <b>5 ans</b> – pour des installations commerciales et industrielles. Se reporter au site <a href="http://www.symmons.com/warranty">www.symmons.com/warranty</a> (en anglais) pour l'information complète concernant la garantie.</p>

## Dimensions

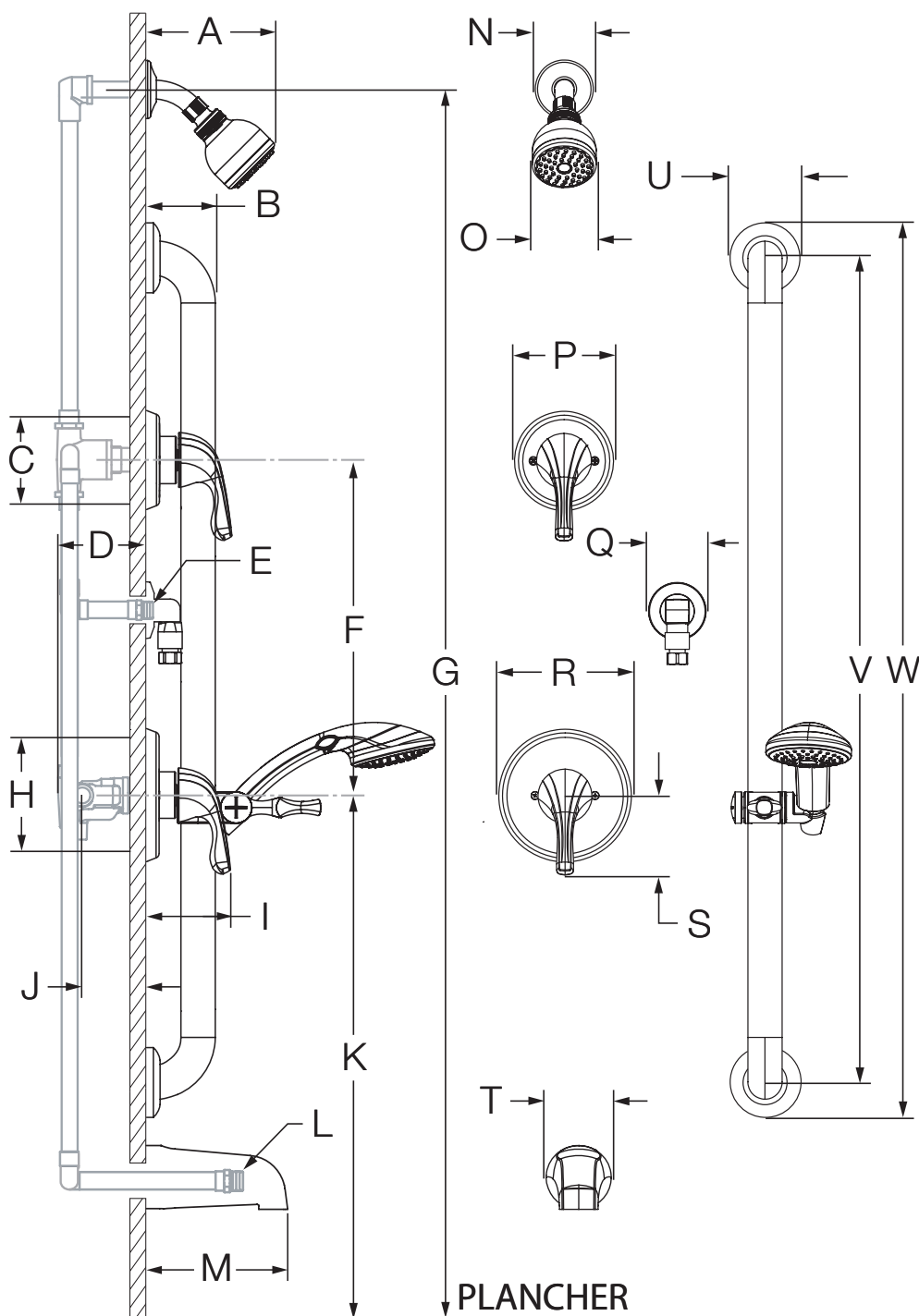

Mesures	
A	6 3/8 po, 162 mm
B	3 po, 76 mm
C	Taille de trou de la vanne de dérivation Min. Ø 3 po, 76 mm Max. Ø 3 1/4 po, 83 mm
D	3 1/2 po, 89 mm
E	Raccord NPT 1/2 po mâle doit faire saillie de 3/8 po du mur fini
F	Réf. 10 po, 254 mm
G	Réf. 77 po, 1956 mm
H	Taille du trou de la vanne de douche Min. Ø 3 po, 76 mm Max. Ø 4 po, 102 mm
I	3 5/8 po, 92 mm
J	Robinetterie brute 2 3/8 po ± 1/2 po, 60 mm ± 13 mm
K	Réf. 32 po, 813 mm
L	Raccord NPT 1/2 po mâle doit faire saillie de 4 po du mur fini
M	5 1/2 po, 140 mm
N	Ø 2 1/2 po, 64 mm
O	Ø 2 3/4 po, 70 mm
P	Ø 4 1/4 po, 108 mm
Q	Ø 2 1/2 po, 64 mm
R	Ø 5 3/4 po, 146 mm
S	3 3/8 po, 86 mm
T	Ø 2 1/2 po, 64 mm
U	Ø 3 1/8 po, 79 mm
V	36 po, 914 mm
W	39 po, 991 mm

### Remarques :

- 1) Toutes les dimensions sont mesurées à partir de la robinetterie brute nominale (voir J en référence).
- 2) Les dimensions sont sujettes à changer sans préavis.



## Liste des pièces

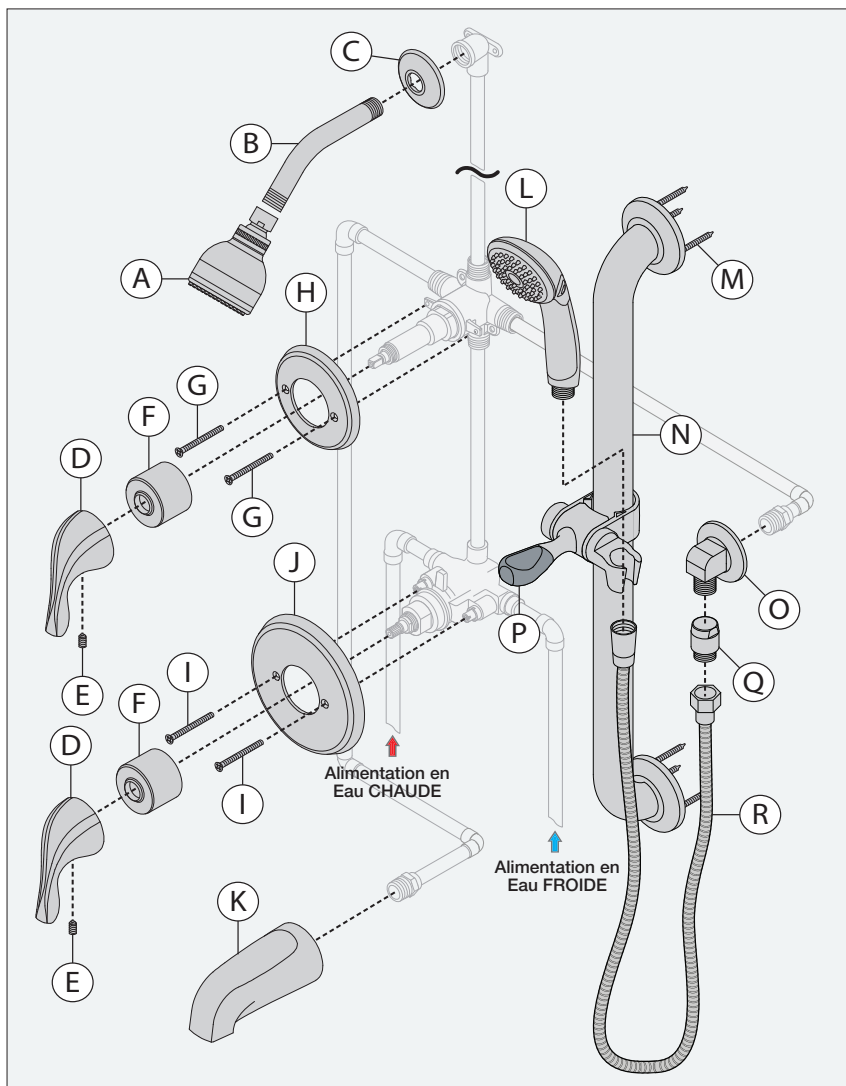

### Remarques :





- 1) Appliquez un joint de silicone autour du périmètre de la garniture de la douche installée à égalité avec le mur fini. Laissez une ouverture au fond de la rosace pour un trou d'évacuation.
- 2) Appliquez du ruban de plombier à toutes les connections filetées.
- 3) Le motif de la rosace dépend du style de la poignée.

### Pièces de remplacement

Article	Description	Numéro de pièce
A	Pomme de douche	4-141*
B C	Bras et bride de douche	300S*
D E	Assemblage de La poignée de dérivation ou de la douche	RTS-063*
F	Couvercle en dôme	T-19*
G H	Organe de dérivation Ensemble de la rosace	96-66-DIV-ESC*
I J	Douche Ensemble de la rosace	Standard 9600-PLR-ESC* Laiton 9600-PLR-B-ESC*
K	Bec de baignoire	060*
L	Douche à main	ADACHS*
O	Coude mural	40A*
Q R	Brise-vide en ligne et boyau de 60 po	SP-4*

\***Remarque** : Juxtaposer le -STN au numéro de pièce pour le Fini nickel satiné.

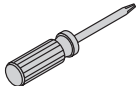
### Outils requis

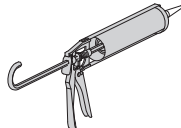
Clef ajustable	
Clef Allen (1/8 po)	
Perceuse	
Tournevis cruciforme	
Ruban de plombier	
Silicone	



## Installation

### Remarque :

Pour l'installation du corps de vanne, veuillez consulter le manuel de corps de vanne.

- 1) Installez la rosace de douche (J) à la vanne de douche. Fixez avec deux vis (I).

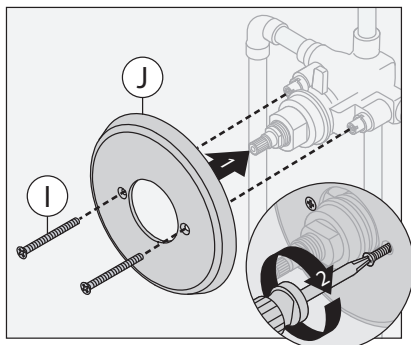

- 2) Installez la rosace de l'organe de dérivation (H) à la vanne de dérivation. Fixez avec deux vis (G).

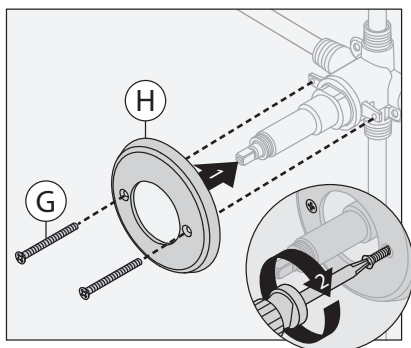

- 3) Installez les couvercles du dôme (F) aux vannes. Tournez dans les sens des aiguilles d'une montre pour fixer en place.

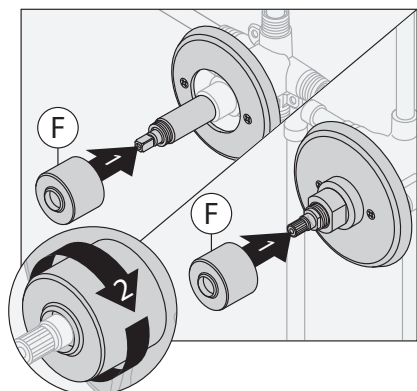

- 4) Installez les poignées (D) aux vannes. Fixez la poignée avec les vis de pression (E).

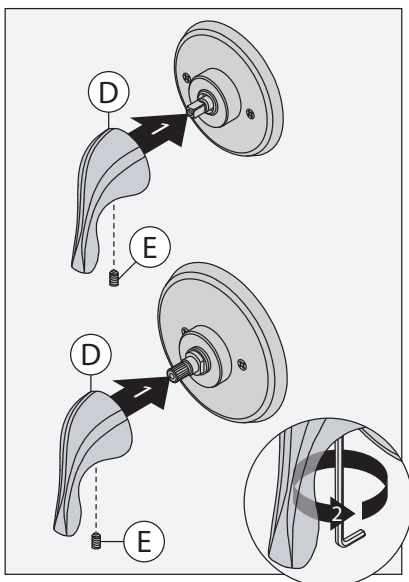

**Remarque :** Les poignées devraient faire face à la position 18h sur l'horloge.

- 5) Installez le bec de baignoire (K) au raccord de tuyauterie. Tournez dans les sens des aiguilles d'une montre pour fixer en place.

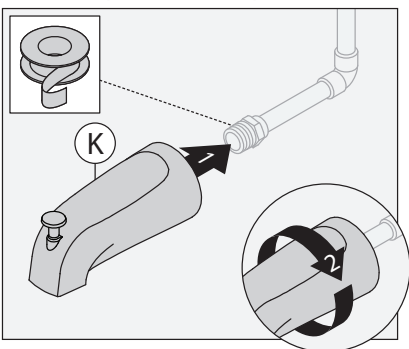

- 6) Attachez le bras de douche (B) et la bride (C) au tuyau de douche vertical. Tournez dans les sens des aiguilles d'une montre pour serrer.

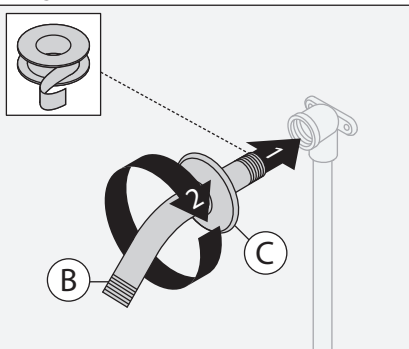

- 7) Installez la pomme de douche (A) au bras de douche (B). Tournez dans les sens des aiguilles d'une montre pour serrer.

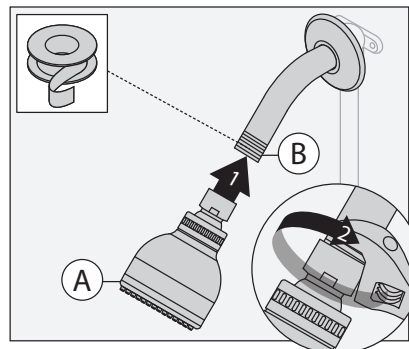

- 8) Enlevez les bouts de la barre à glissière (N1) des brides de la barre. En utilisant les brides comme guide, percez des trous de guidage de 1/8 de po dans les poteaux ou blocs de bois. Avec la barre à glissière (N) en place, fixez-la au mur en utilisant les vis (M). Attachez les bouts de la barre à glissière (N1) aux brides de la barre.

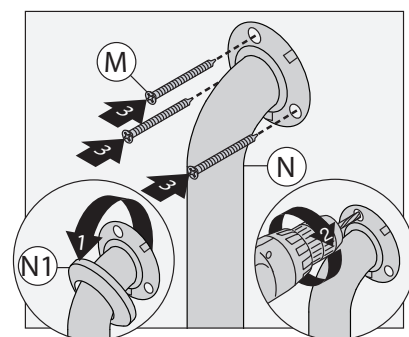

**Remarque :** La barre à glissière doit être fixée avec au moins deux des trois vis (M) à chaque bout.

- 9) Démontez l'assemblage de la glissière (P).

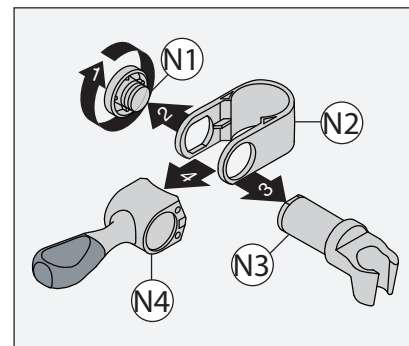

## Installation

- 10) Installez l'assemblage de la glissière (P) à la barre à glissière (N). Le bord plat sur (P2) et (P3) doit être aligné. Les flèches sur (P2) et (P4) indiquent le côté au fond.

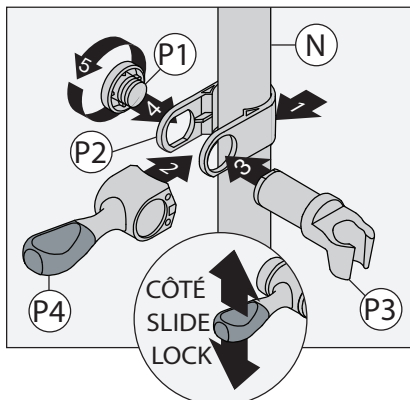

**Remarque :** Ajustez le couvercle à vis (P1) pour faciliter le mouvement de l'assemblage de la glissière.

- 11) Appuyez les languettes sur la bride du coude mural et installez le coude mural (O) au raccord de tuyauterie. Tournez dans les sens des aiguilles d'une montre pour fixer en place.

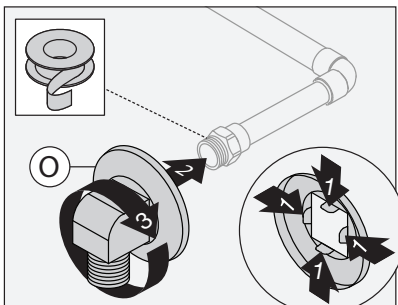

- 12) Attachez la douche à main (L) au boyau (R). Attachez le boyau (R) au brise-vide (Q). Connectez le brise-vide (Q) au coude mural (O). Tournez dans les sens des aiguilles d'une montre pour serrer.

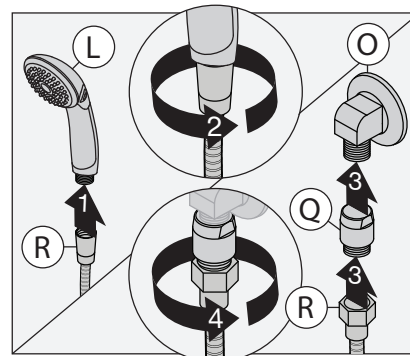

## Fonctionnement (Contrôle de la température)

- 1) Tournez la poignée de douche dans le sens contraire des aiguilles d'une montre approximativement 1/4 de tour pour mettre la vanne dans la position d'eau froide.

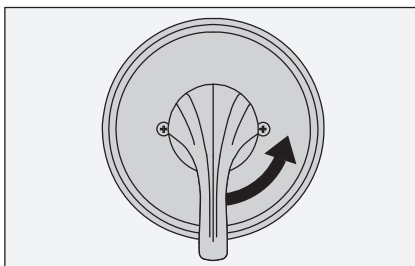

- 2) Tournez la poignée de douche dans le sens contraire des aiguilles d'une montre approximativement 1/2 de tour pour mettre la vanne dans la position d'eau tiède.

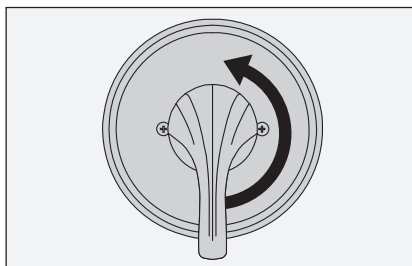

- 3) Tournez la poignée de douche dans le sens contraire des aiguilles d'une montre approximativement 3/4 de tour pour mettre la vanne dans la position d'eau chaude.

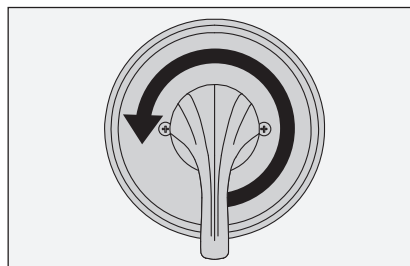

## Fonctionnement (Contrôle de dérivation)

- 1) La cartouche est réglée en usine pour dévier à la fonction 1.

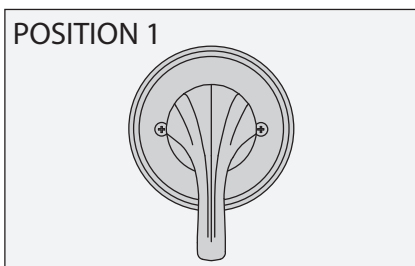

- 2) Tournez la poignée à la position 2 pour partager les fonctions 1 et 3.

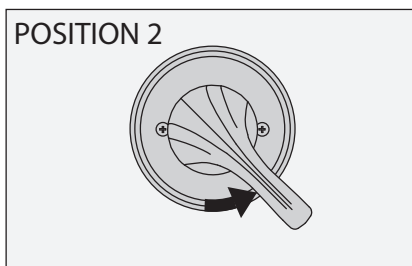

- 3) Tournez la poignée à la position 3 pour dévier vers la fonction 3.

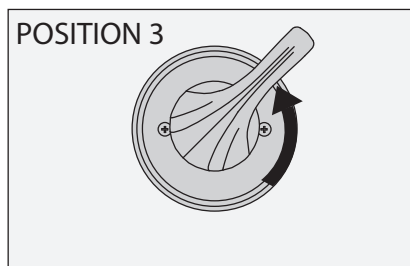

## Fonctionnement (Contrôle de dérivation)

4) Tournez la poignée à la position 4 pour partager les fonctions 2 et 3.

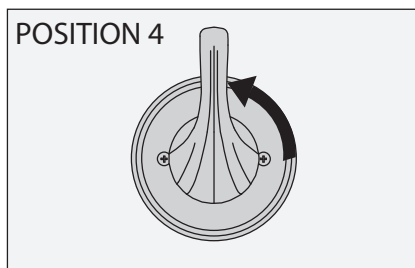

5) Tournez la poignée à la position 5 pour dévier vers la fonction 2.

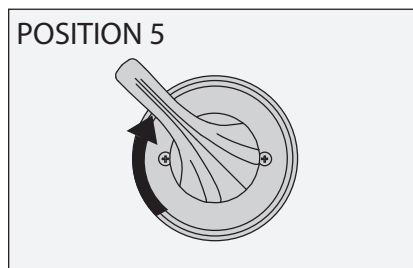

6) Tournez la poignée à la position 6 pour partager les fonctions 1 et 2.

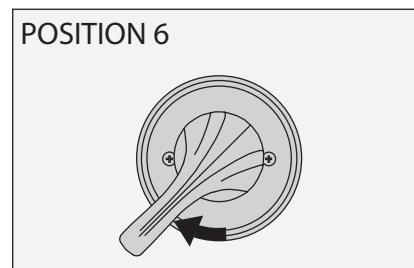

## Tableau de résolution des problèmes

Symptôme	Cause	Solution
Le fini est tâché.	Les éléments dans l'alimentation en eau peuvent causer des tâches sur le fini.	Nettoyez la boiserie avec un chiffon doux en utilisant un savon doux et de l'eau ou un nettoyant non abrasif et rincez rapidement avec de l'eau.